

ARMY TM 9-1005-319-10
AIR FORCE TO.11W3-55-41
NAVY SW 370-BUJ-OPI-010

Supersedes copy dated August 1986.
See page i for details.

**OPERATOR'S MANUAL
FOR**

RIFLE, 5.66 MM, M16A2 W/E (1005-01-128-9936) (EIC:4GM)
RIFLE, 5.56 MM, M16A3 (1005-01-367-5112)
RIFLE, 5.56 MM, M16A4 (1005-01-383-2872)(EIC:4F9)
CARBINE, 5.56 MM, M4 W/E (1005-01-231-0973) (EIC:4FJ)
CARBINE, 5.56 MM, M4A1 (1005-01-382-0953) (EIC:4GC)

*See inside cover for distribution statement.

HEADQUARTERS, DEPARTMENT OF THE ARMY

OCTOBER 1998

DISTRIBUTION STATEMENT C: Distribution authorized to U.S. Government agencies and their contractors. This publication is required for administration and operational purposes, as determined on October 1, 1997. **ARMY ONLY:** Other requests for this document will be referred to Director, Armament and Chemical Acquisition and Logistics Activity, ATTN: AMSTA-AC-NML Rock Island, IL 61299-7630. **AIR FORCE ONLY:** Other requests for this document must be referred to Waner Robins ALC/ZDTA, Robins AFB, GA 31098-5609. **NAVY ONLY:** Other requests for this document must be referred to: commander, Code 4081 Bldg 2521, NAVSURF WARCENDIV, 300 Hwy 361, Crane, IN 47622-5001.

DESTRUCTION NOTICE - Destroy by any method that will prevent disclosure of contents or reconstruction of the document.

WARNING

Before starting an inspection, be sure to clear the weapon. Do not squeeze the trigger until the weapon has been cleared. Inspect the chamber to ensure that it is empty and no ammunition is in position to be chambered. Do not keep live ammunition near work area.

Use only blank M200 with the BFA and DO NOT fire directly at anyone less than 20 feet away.

To be considered SAFE before disassembly, cleaning, inspecting, transporting, or storing, the weapon must be cleared.

With the bolt carrier assembly locked to the rear or in its forward position, if the weapon is dropped or jarred with a loaded magazine in place, it could chamber a round.

When your weapon is loaded, ensure it is pointed in a safe direction.

Do not load with a hot chamber.

WARNING (Cont)

If your weapon stops firing with a live round in the chamber of a hot barrel, remove the round fast. However, if you cannot remove it within 10 seconds, remove magazine and wait 15 minutes with the weapon pointing in a safe direction. This way you won't get hurt by possible round cooking off. Regardless, keep your face away from the ejection port while clearing a hot chamber.

DON'T OVERHEAT BARRELS. Sustained firing of the weapon will rapidly raise the temperature of the barrel to a critical point

Firing 140 rounds, rapidly and continuously, will raise the temperature of the barrel to the **COOKOFF POINT**. At this temperature, any live round remaining in the chamber for any reason may cook off (detonate) in as short a period as 10 seconds.

If the cookoff point (or temperature) is felt possible, weapon should be immediately cleared and allowed to cool.

Sustained rate of fire for the weapon is 12-15 rounds per minute. This is the actual rate of fire that a weapon can continue to deliver for an indefinite length of time without serious overheating.

WARNING (Cont)

Sustained rate of fire should never be exceeded except under circumstances of extreme urgency.

Exceeding the sustained rate of fire can result in a catastrophic failure of the barrel and injury or death to personnel.

When disassembling, turn magazine away from face, spring is under compression.

If an audible 'POP' or reduced RECOIL is experienced during firing, immediately CEASE FIRE. Either condition could indicate an incomplete powder burn and/or a bullet stuck in the bore.

Do not fire if water is present in barrel.

DO NOT interchange bolts between weapons.

Be sure the cam pin is installed in the bolt group. If it isn't, your weapon can still fire and will explode.

WARNING (Cont)

DO NOT FIRE:

Seriously corroded ammunition.

Dented cartridges.

Cartridges with loose bullets.

cartridges exposed to extreme heat (135°) until they have cooled.

Cartridges with the bullet pushed in (short rounds).

Make sure your weapon is clear and on SAFE before moving down range.

**TECHNICAL MANUAL
NO. 9-1005-319-10**

***TM 9-1005-318-10
TO 11W35-5-41
SW 370-BU-OPI-010
HEADQUARTERS
DEPARTMENTS OF THE ARMY,
AIR FORCE, AND NAVY
Washington D.C., 1 October 1998**

**OPERATOR'S MANUAL
FOR**

**RIFLE, 5.56 MM, M16A2 W/E (1005-01-128-9936) (EIC:4GM)
RIFLE, 5.56 MM, M16A3 (1005-01-367-5112)
RIFLE, 5.56 MM, M16A4 (1005-01-383-2872) (EIC:4F9)
CARBINE, 5.56 MM, M4 W/E (1005-01-231-0973) (EIC:4FJ)
CARBINE, 5.56 MM, M4A1 (1005-01-0953) (EIC:4GC)**

REPORTING ERRORS AND RECOMMENDING IMPROVEMENTS

You can help improve this manual. If you find any mistakes or if you know of a way to improve the procedures, please let us know. Mail your letter or DA Form 2028 (Recommended Changes to Publications and Blank Forms) direct to: Director, Armament and Chemical Acquisition and Logistics Activity, ATTN: AMSTA-AC-NML, Flock Island, IL 612299-7630. A reply will be furnished to you.

This manual supersedes TM 9-1005-319-10, August 1986, including all changes.

DISTRIBUTION STATEMENT C: Distribution authorized to U.S. Government agencies and their contractors. This publication is required for administration and operational purposes, as determined on October 1, 1997. **ARMY ONLY:** Other requests for this document will be referred to Director, Armament and Chemical Acquisition and Logistics Activity, ATTN: AMSTA-AC-NML Rock Island, IL 61299-7630. **AIR FORCE ONLY:** Other requests for this document must be referred to Warner Robins ALC/LZDTA, Robins AFB, GA 31096-5609. **NAVY ONLY:** Other requests for this document must be referred to: Commander, Code 4081 Bldg 2521, NAVSURF WARCENDIV, 300 Hwy 361, Crane, IN 47622-5001.

DESTRUCTION NOTICE - Destroy by any method that will prevent disclosure of contents or reconstruction of the document.

TABLE OF CONTENTS

	WP Sequence No.
CHAPTER 1 INTRODUCTION	
General Information	0001 00
Equipment Description	0002 00
Location And Description Of Major Components	0003 00
Principles Of Operation	0004 00
CHAPTER 2 OPERATING INSTRUCTIONS	
Description And Use Of Operator's Controls And Indicators	0005 00
Preventive Maintenance Checks And Services (PMCS)	0006 00
Installation of Equipment	0007 00
Operations Under Usual Conditions	0008 00
Operations Under Unusual Conditions	0009 00
Functional Check	0010 00
25 Meter Zeroing Procedures	0011 00
Troubleshooting	0012 00
CHAPTER 3 MAINTENANCE INSTRUCTIONS	
Disassembly Instructions	0013
Cleaning Instructions	0014

TABLE OF CONTENTS (Cont)

	WP Sequence No.
CHAPTER 3 MAINTENANCE INSTRUCTIONS (Cont)	
Inspection Instructions	0015
Lubrication Instructions	0016
Reassembly Instructions	0017
CHAPTER 4 M4 AND M5 ADAPTER RAILS	
Installation and Removal of the Adapter Rails	0018
Adapter Rails Maintenance	0019
Adapter Rail Accessory Mounting Procedures	0020
CHAPTER 5 AMMUNITION	
Ammunition	0021
APPENDIX A REFERENCE PUBLICATIONS	0022
APPENDIX B COMPONENTS OF END ITEM,	0023
BASIC ISSUE ITEMS,	0024
ADDITIONAL AUTHORIZATION ITEMS, AND	0025
EXPENDABLE/DURABLE SUPPLIES, AND MATERIALS	0026

CHAPTER 1
INTRODUCTION

SCOPE

This manual provides operation and maintenance instructions for the M16A2, M16A3, M16A4 Rifles, M4 and M4A1 Carbines. These weapons are lightweight, gas-operated, air-cooled, magazine-fed, shoulder-fired weapons that can be fired in either automatic, three-round bursts, or semiautomatic.

The purpose of the weapons is to provide personnel an offensive/defensive capability to engage targets in the field. The adapter rails allows the operator the capability to mount various accessories on to the M16A4 Rifle and the M4/M4A1 Carbines.

When a procedure is common to M16 rifle and M4 Carbine, ONLY the M16A2 configuration will be depicted. If a procedure is not common to both -weapons, the procedure will be incorporated and the weapon will be identified. If your weapon is configured with adapter rails, refer to the appropriate appendices in this manual for operation and maintenance procedures for the adapter rails.

MAINTENANCE FORMS AND PROCEDURES

Department of the Army forms and procedures used for equipment maintenance will be those prescribed by DA Pam 738-750, as contained in Maintenance Management Update. Refer to the latest issue of DA Pam 25-30 to determine whether there are new editions, changes or additional publications pertaining to the equipment.

CORROSION PREVENTION AND CONTROL (CPC)

Corrosion prevention and control of materiel is a continuing concern. It is important that any corrosion problems with this equipment be reported so that the problem can be corrected and improvements made to prevent the problem in future equipment.

CORROSION PREVENTION AND CONTROL (CPC) (Cont)

While corrosion is typically associated with rusting metal, it can also include deterioration of other materials such as contacts, injection molded plastic, and foam inserts in the case. Unusual cracking, softening, swelling, or breaking of these other materials may be corrosion problem.

If a corrosion problem is identified, report it using Standard Form 368, *Product Quality Deficiency Report*. Use keywords such as "corrosion," rust," "deterioration." or 'cracking' to ensure that the information is identified as a CPC problem. Submit the form to the address specified in DA Pam 738-750.

DESTRUCTION OF MATERIAL TO PREVENT ENEMY USE

For procedures to destroy this equipment to prevent its use by the enemy, refer to TM 750-244-2.

REPORTING EQUIPMENT IMPROVEMENT RECOMMENDATIONS (EIR)

You can help improve this manual. if you find any mistakes or if you know of a way to improve the procedures, please let us know. Mail your letter or DA Form 2028 (Recommended Changes to Publications and Blank Forms) direct to: Director, Armament and Chemical Acquisition and Logistics Activity, ATTN: AMSTA-AC-NML, Rock Island, IL 61299-7630. A reply will be furnished to you.

END OF TASK

EQUIPMENT CHARACTERISTICS, CAPABILITIES, AND FEATURESM16A2/M16A3

Caliber	5.56 mm
Weight.....	w/30 (loaded) round mag approx 8.79 lbs
Length	w/compensator 39-5/8 in
Mechanical Features	Rifling (RH 1/7 twist)
Firing Characteristics:	
Muzzle Velocity	3100 fps
Chamber Pressure	52,000 psi
Cyclic Rate of Fire	700-900 rpm (approx.)
Max Effective Rates of Fire:	
Semi.....	45 rpm
Burst/Auto.....	90 rpm
Sustained Rate of Fire.....	12/15 rpm
Max Effective Range	550 m (individual/point targets)
800 m (area targets)	
Max Range.....	3600 m
Fire Selector.....	SAFE-SEMI-BURST (M16142)
SAFE-SEMI-AUTO (M16A3)	

EQUIPMENT CHARACTERISTICS, CAPABILITIES, AND FEATURES (Cont)**M16A4**

Caliber..... 5.56 mm
Weight..... w/30 (loaded) round mag 8.79 lbs
Length 39-5/8 in
Mechanical Features:
 Rifling(RH 1/7 twist)
 Detachable carrying handle w/integral accessory mounting rail
Firing Characteristics:
 Muzzle Velocity 3100 fps
 Chamber Pressure -52.000 psi
 Cyclic Rate of Fire..... 800 rpm (approx)
 Fire Selector..... SAFE-SEMI-BURST
Max Effective Rate of Fire:
 Semi 45 rpm
 Burst 90 rpm
 Sustained rate of Fire 12/15 rpm
Max Effective Range 550 meters (individual/point targets)
600 meters (area targets)
Max Range 3600 meters

M4/M4A1 CARBINE

Caliber.....	5.56 mm
Weight.....	w/30 (loaded) round mag 7.5 lb
Length	Buttstock Closed 29.75 in Buttstock Opened 33.0 in

Mechanical Features:

- Riffling(RH 1/7 twist)
- Detachable carrying handle w/integral accessory mounting rail
- Buttstock has four positions; closed, 1 R open, 3/4 open, and fully Open.

Firing Characteristics:

Muzzle Velocity.....	2,970 fps
Chamber pressure.....	.52,000 psi
Cyclic Rate of Fire.....	700-970 rpm (approx.)
Fire Selector.....	SAFE-SEMI-BURST (M4) SAFE-SEMI-AUTO (M4A1)

Max Effective Rate of Fire:

Semi	45rpm
Burst/Auto.....	90 rpm

EQUIPMENT CHARACTERISTICS, CAPABILITIES, AND FEATURES (Cont)**M4/M4A1 CARBINE (Cont)**

Sustained Rate of Fire 12/15 rpm
Max Effective Range..... 500 meters (individual/point targets)
 600 meters (area targets)
Max Range.....3600 meters

END OF TASK

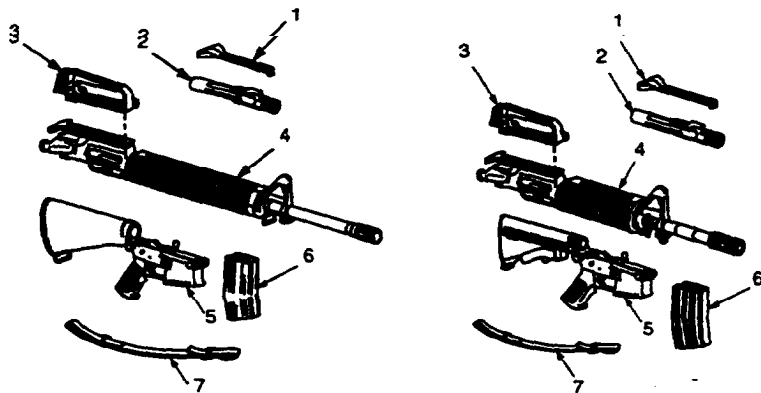

Figure 1-1. M16A2 and M16A3 Rifle.

- 1 **CHARGING HANDLE ASSEMBLY.** Provides initial charging of the weapon. The charging handle locks in the forward position during sustained fire to prevent injury to the operator.
- 2 **BOLT AND BOLT CARRIER ASSEMBLY.** Provides stripping, chambering, locking, firing, extraction, and ejection of cartridges using the drive springs and projectile propelling gases for power.
- 3 **UPPER RECEIVER AND BARREL ASSEMBLY.** Provides support for the bolt carrier assembly. The barrel chambers the cartridge for firing and directs the projectile.
- 4 **LOWER RECEIVER AND BUTTSTOCK ASSEMBLY.** Provides firing control for the weapon and provides storage for basic cleaning materials.
- 5 **CARTRIDGE MAGAZINE.** Holds cartridges ready for feeding and provides a guide for positioning cartridges for stripping. Provides quick reload capabilities for sustained firing.
- 6 **SMALL ARMS SLING.** Provides the means for carrying the weapon.

END OF TASK

0003 00-1

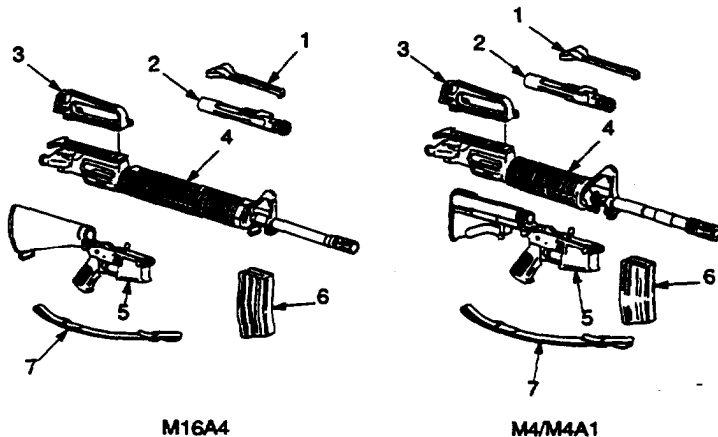

Figure 1-2. M16A4, M4 and M4A1 Carbine

- 1 **CHARGING HANDLE ASSEMBLY.** Provides initial charging of the weapon. The charging handle locks in the forward position during sustained fire to prevent injury to the operator.
- 2 **BOLT AND BOLT CARRIER ASSEMBLY.** Provides stripping, chambering, locking, firing, extraction, and ejection of cartridges using the drive springs and projectile propelling gases for power.
- 3 **DETACHABLE CARRYING HANDLE.** May be removed for attachment of various accessories to the integral accessory mounting rail.
- 4 **UPPER RECEIVER AND BARREL ASSEMBLY.** Provides support for the bolt carrier assembly. The barrel chambers the cartridge for firing and directs the projectile.
- 5 **LOWER RECEIVER AND BUTTSTOCK ASSEMBLY.** provides firing control for the weapon. Provides storage for M16A4 basic cleaning materials Adjustable buttstock for M4/M4A1.
- 6 **CARTRIDGE MAGAZINE.** Holds cartridges ready for feeding and provides a guide for positioning cartridges for stripping. Provides quick reload capabilities for sustained firing.
- 7 **SMALL ARMS SUNG.** Provides the means for carrying the weapon.

END OF TASK

NOTE

Magazine may be inserted with bolt assembly open closed.

1. Place selector lever on SAFE.
2. Insert loaded cartridges magazine in magazine well and chamber a round.
3. Face the target, place the weapon to your shoulder, move the selector lever from SAFE to SEMI or AUTO/BURST.
4. Aline the front and rear sight with the target and squeeze the trigger.
5. Squeezing the trigger releases the hammer, which strikes the firing pin, causing it to impact the primer of the round.
6. The primer ignites the propellant in the round.

7. Gas from the burning propellant pushes the projectile along the barrel of the weapon.
8. The rifling in the barrel causes the projectile to rotate which provides stability during flight to the target.
9. When round reaches approximate end of barrel, expanding gases from the burning propellant pass through gas port, gas tube and into the bolt carrier assembly forcing it to the rear. This causes the bolt to extract and eject the spent cartridge case and chamber a new round.

END OF TASK

CHAPTER 2
OPERATING INSTRUCTIONS

This page left blank intentionally.

RIGHT VIEW.

1. **ELEVATION KNOB.** Allows operator to adjust sights for range changes.
2. **WINDAGE KNOB.** Allows operator to adjust to correct for effects of wind.
3. **REAR SIGHT ASSEMBLY.** Contains short range (0-200m) and long range (300+m) apertures and adjustment controls.
4. **BRASS DEFLECTOR.** Prevents ejected cartridge case from striking operator.
5. **FRONT SIGHT ASSEMBLY.** Contains adjustment front sight post.
6. **BAYONET LUG.** Allows operator to attach bayonet to weapon.
7. **EJECTION PORT COVER.** Closes over ejection port to prevent sand, dust, ect., from entering chamber. Should remain closed when not firing the weapon.
8. **CARTRIDGE MAGAZINE.** Contains up to 30 rounds of 5.56 mm ammunition.
9. **MAGAZINE CATCH.** Holds magazine in place in magazine well and allows operator to release magazine and remove it from weapon.
10. **TRIGGER.** When activated by operator, initiates firing sequence.
11. **FORWARD ASSIST ASSEMBLY.** Ensures that the bolt is fully closed and locked.
12. **CHARGING HANDLE.** Allows the operator to chamber a round and cock the weapon.

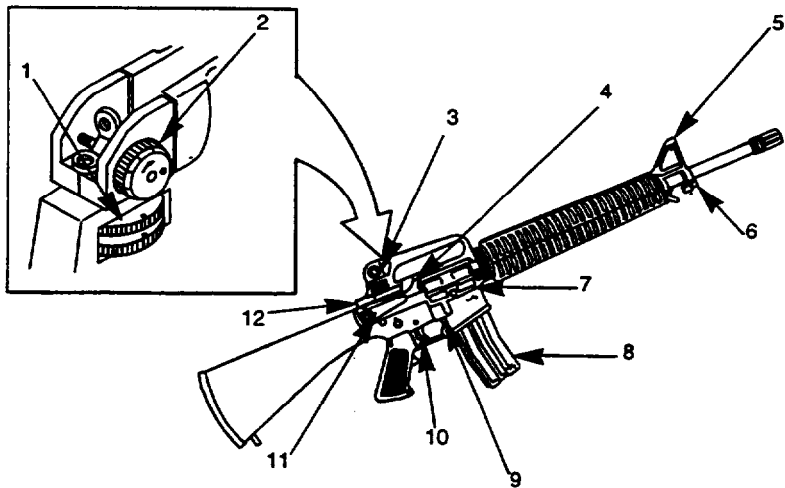

Figure 2-1. Right Side View

LEFT VIEW

1. **COMPENSATOR.** Prevents the muzzle of the weapon from rising during firing.
2. **CARRYING HANDLE.** Allows the operator to carry the weapon.
3. **FROM SIGHT POST.** Allows operator to adjust strike of bullet up and down.
4. **BOLT CATCH.** Holds the bolt assembly to rear when last round is fired.
5. **BUTTSTOCK ASSEMBLY.** Houses the action spring, buffer assembly, and extension assembly.
6. **SUNG SWIVEL.** Allows operator to attach sling to the weapon.
7. **SELECTOR LEVER.** Allows the operator to select the mode of fire and place weapon on safe.
8. **SLIP RING.** Holds the handguards in place on the weapon.

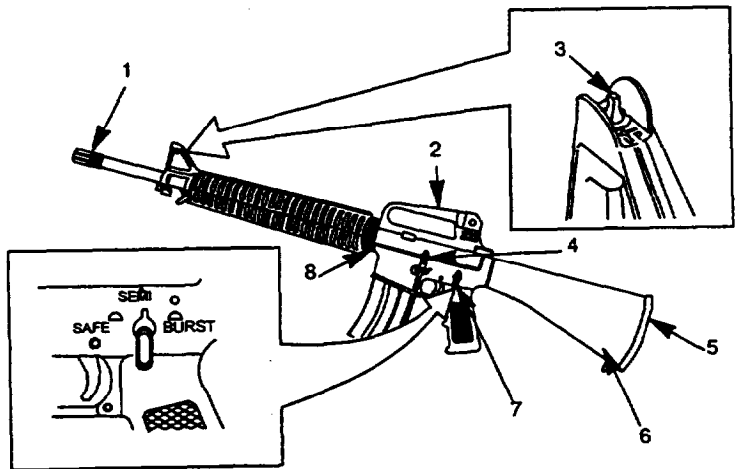

Figure 2-2. Left Side View.

END OF TASK

0005 00-5/6 blank

PREVENTIVE MAINTENANCE CHECKS AND SERVICES

(PMCS)

0006 00

GENERAL

To ensure the readiness of your weapon, perform the preventive maintenance procedures in accordance with Table 1, prior to each mission. Preventive maintenance procedures include inspection, cleaning, and performance of the checkout procedures.

EXPLANATION OF TABLE ENTRIES

Item Number Column. Numbers in this column are for references. When completing Equipment Inspection and Maintenance Worksheet, include the item number for the check/service indicating a fault. Item numbers also appear in the order that you must do checks and services for the intervals listed.

Interval Column. This column tells you when you must do the procedure in the procedure column. BEFORE (B) procedures must be done before you operate or use the equipment for its intended mission. DURING (D) procedures must be done during the time you are operating or using the equipment for its intended mission. AFTER (A) procedures must be done immediately after you have operated or used the equipment.

PREVENTIVE MAINTENANCE CHECKS AND SERVICES

(PMCS) (Cont)

0006 00

Man-Hour Column. This column indicates the man-hours required to complete the required procedure.

Item to be Checked or Service Column. This column provides the location and the time to be checked or serviced. The item location is underlined.

Procedure Column. This column gives the procedure you must do to check or service the item listed in the Check/Service column to know if the equipment is ready or available for its intended mission or for operation. You must do the procedure at the time stated in the interval column.

"Equipment Not Ready/Available If:" Column. Information in this column tells you what faults will keep your equipment from being capable of performing its primary mission. If you make check and service procedures that Show faults listed in this column, do not operate the equipment Follow standard operating procedures for maintaining the equipment or reporting equipment failure.

THIS WORK PACKAGE COVERS:

PMCS checks and services

INITIAL SETUP:

Operator

WARNING

Before starting an inspection, be sure to clear the weapon. DO NOT squeeze the trigger until the weapon has been cleared. Inspect the chamber to ensure that it is empty and no ammunition is in position to be chambered. Do not keep ammunition near work area.

NOTE

An inactive weapon is a weapon, whether assigned or not assigned to an individual, that is stored in an arms room for a period of 90 days. Performance of normal cleaning (PMCS) of an inactive weapon will be performed every 90 days.

**PREVENTIVE MAINTENANCE CHECKS AND SERVICES
(PMCS) (Cont)**

0006 00

WARNING

Before starting an inspection, be sure to clear the weapon (WP 0013 00-1). Do not keep live ammunition near work area.

Table 1. Preventive Maintenance Checks and Services

Item	Interval	Man-Hour	Item To Be Checked Or Serviced	Procedure	Equipment Not Ready/Available If:
1	Before		Magazine	Magazine slips easily into the magazine well and locks in place.	Magazine is distorted or is hard to seat, or doesn't lock in magazine wall.
	Before			Magazine follower has spring tension and moves easily inside of magazine.	Magazine follower is stuck or has weak spring tension.

0006 00-4

Item	Interval	Man-Hour	Item To Be Checked Or Serviced	Procedure	Equipment Not Ready/Available If:
2	Before		Upper Receiver - Barrel	Check for barrel looseness (using hand pressure only).	Barrel is loose enough to be moved by hand.
3	Before/ During		Detachable Carrying Handle Assembly (M16A4/M4/M4A1)	Check for missing or damaged parts and insure the handle assembly will mount to the upper receiver. Check carrying handle nuts to ensure they are hand tight.	Handle assembly is missing or has damaged parts, or will not mount to upper receiver.
4	Before		Weapon Sights (Zero Adjustment)	Move front and rear sight to make sure they can be adjusted. Return sights to zero setting on your weapon.	If the sights are damaged, missing, or can't be adjusted.

**PREVENTIVE MAINTENANCE CHECKS AND SERVICES
(PMCS) (Cont)**

0006 00

Table 1. Preventive Maintenance Checks and Services

Item	Interval	Man-Hour	Item To Be Checked Or Serviced	Procedure	Equipment Not Ready/Available If:
5	Before		Magazine Catch (Function)	<p>Insert magazine into well. The magazine catch should hold the magazine in place.</p> <p>Pressing the magazine catch button should release the magazine. To adjust the magazine catch, used cleaning rod to press in on the magazine catch button until the left side of the</p>	If the magazine catch will not retain or release the magazine.

Item	Interval	Man-Hour	Item To Be Checked Or Serviced	Procedure	Equipment Not Ready/Available If;
5 (cont)				magazine catch sticks out beyond the receiver. To tighten turn the magazine catch clockwise; to loosen, turn it counterclockwise.	
6	Before		Visual inspection of Weapon	Look the weapon over for missing or damaged parts. Report missing or damaged parts to armor.	Parts are missing or damaged to a point of being unserviceable.

**PREVENTIVE MAINTENANCE CHECKS AND SERVICES
(PMCS) (Cont)**

0006 00

Table 1. Preventive Maintenance Checks and Services

Item	Interval	Man-Hour	Item To Be Checked Or Serviced	Procedure	Equipment Not Ready/Available If:
7	During		Periodic Inspection of Weapon.	Periodically check weapon to make sure it's clean and there is no foreign material in bore. If foreign material is in bore, cleaning bore (WP 0014 00-1).	If foreign material is in bore.
8	During		Maintenance Performed During Firing Operations	Clean and lubricate weapon (WP 0014 00-1) after firing approximately 200 rounds of ammunition or at the end of the day.	

0006 00-8

Item	Interval	Man-Hour	Item To Be checked or Serviced	Procedure	Equipment Not Ready/Available If:
9	After		Maintenance of weapon and Equipment	Disassemble weapon (WP 0013 00-1). Clean and lubricate according to WP 0014 00 and 0016 00. Disassemble magazine (WP 0017 00-14). Clean and lubricate. Report all damaged or missing parts to unit armor.	If parts are missing or damaged.
10	Before/After			Perform functional check (WP 0010 00)	If weapon fails function check.

END OF TASK

0006 00-9/10 blank

M15A2/M23 BLANK FIRING ATTACHMENT (BFA)**WARNING**

Before installation, be sure to clear the weapon.

Use only blank M200 with the BFA and do not fire directly at anyone less than 20 feet away.

NOTE

M23 BFA is stamped "M4 Carbine Only", painted yellow and is used on the M4 and M4A1 carbines. M15A2 BFA is painted red and used on the M16A2, M16A3, and M16A4 rifles.

1. Unscrew and slide all the way to the back

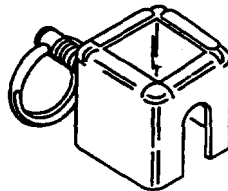

M15A2/M23 BLANK FIRING ATTACHMENT (BFA) (Cont)**CAUTION**

Do not use tools to tighten attachment. HANDS ONLY.

NOTE

After 50 rounds, check to see if it is still tight, Make sure to clean carbon buildup after each use.

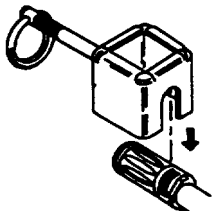

2. Hook behind first groove of compensator.

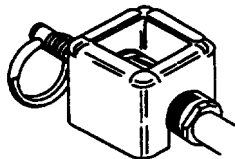

3. Slide into compensator end
HAND TIGHTEN.

WARNING

Be installation, be sure to clear the weapon.

TOP SUNG ADAPTER

1. Remove weapon sling from weapon.

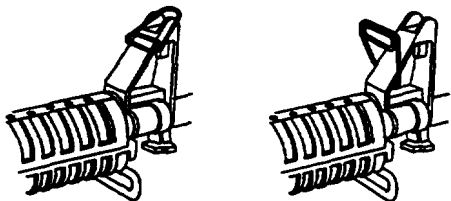
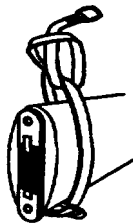

2. Work adapter sling through swivel and through loop.

3. Work buckle under and then through loop.
4. Attach clamp.
5. Attach rifle sling to top sling adapter.

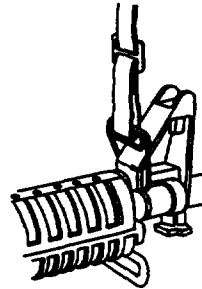

END OF TASK

CLEARING WEAPON**WARNING**

TO be considered SAFE before disassembly, cleaning, inspecting, transporting, or storing, the weapon must be cleared.

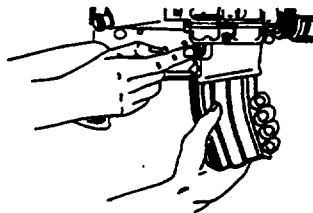
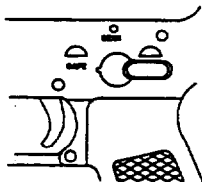

1. Point in a SAFE DIRECTION!
Place selector lever on SAFE. If weapon is not cocked, lever can not be pointed toward SAFE.
2. Remove cartridge magazine by depressing magazine catch button and pulling cartridge magazine down.

CLEARING WEAPON (Cont)

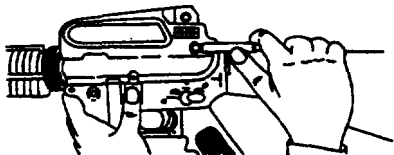

3. To lock bolt open, pull charging handle rearward. Press bottom of bolt catch and allow bolt to move forward until it engages bolt catch. Return charging handle to full forward position. If you haven't before, place selector lever on SAFE.

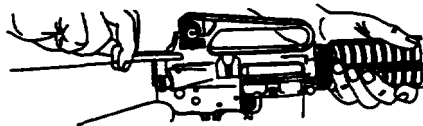

4. Check receiver and chamber to ensure these areas contain no ammo.

CLEARING WEAPON (Cont)

5. With selector lever pointing toward SAFE, allow bolt to go forward by pressing upper portion of bolt catch.

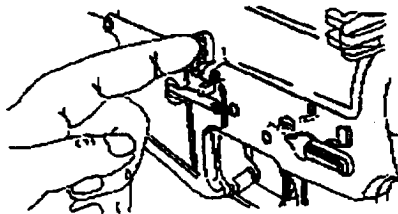

OPERATION

WARNING

With the bolt carriers assembly locked to the rear or in its forward position, if the weapon is dropped or jarred with a loaded magazine in place, it could chamber a round.

1. USE OF SELECTOR LEVER

- a. Safe. Weapon will not fire. Selector lever cannot be on SAFE unless weapon is cocked. Always place on SAFE when loading and unloading.

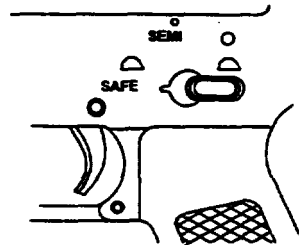

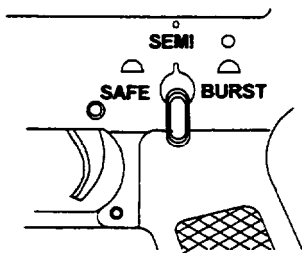

- b. SEMI. Weapon will fire one round each time the trigger is pulled.

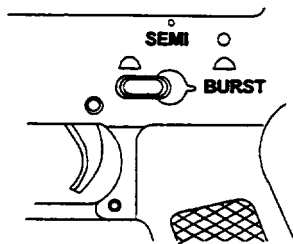

- c. BURST. Weapon will fire a three-round burst each time the trigger is pulled.

OPERATION (Cont)

- d. AUTO (M4A1 and M16A3 only).
Weapon will continue to fire as long as the trigger is pulled.

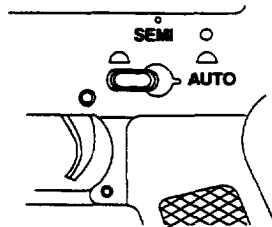

NOTE

Magazine may be loaded with bolt assembly open or closed.

2. Loading for Semiauto Fire and Chambering a Round.

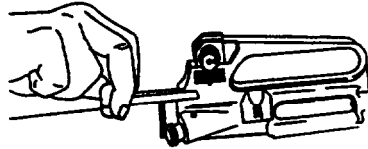
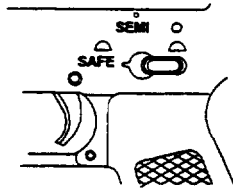

- a. With hammer cocked, place selector lever on SAFE. Point muzzle in safe direction.
- b. Open bolt and check chamber. Make sure it is clear. Press bottom of bolt catch and allow bolt to move forward until it engages bolt catch. Return charging handle to full forward position.

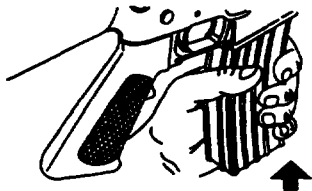
OPERATION (Cont)

- c. Push upward until magazine catch engages and holds magazine.

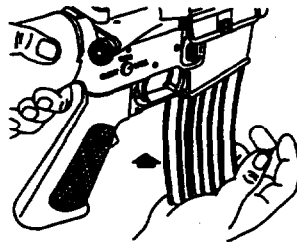

- d. Tap upward to make sure it is seated right.

WARNING

Your weapon is now loaded. Ensure it is pointed in a SAFE direction.

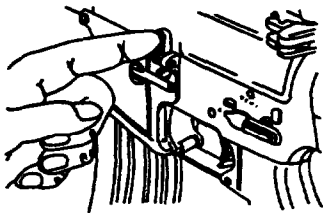

e. Depress upper portion of bolt catch. Bolt should go forward.

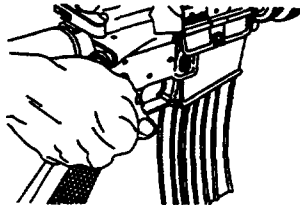

f. Tap forward assist to ensure bolt is fully forward and locked.

OPERATION (Cont)

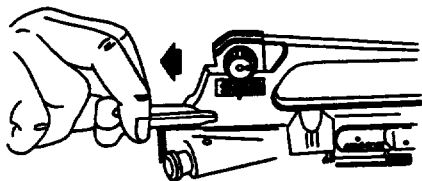

g. Chambering a round from the bolt closed position; with magazine inserted, pull charging handle fully rearward.

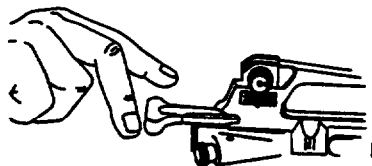

h. Release the charging handle.

CAUTION

Never 'ride' the charging handle. Let it go forward on its own.

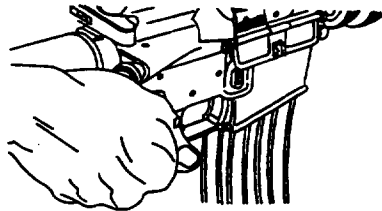
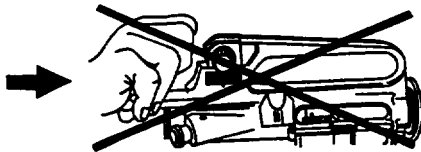

- i. Tap forward assist to ensure bolt is fully forward and locked.

OPERATION (Cont)**NOTE**

If weapon is not to be fired immediately, dose ejection port cover.

3. THREE-ROUND BURST CONTROL**WARNING**

If a noticeable difference in sound or recoil is experienced, STOP FIRING. Either condition could indicate an incomplete powder burn and/or a bullet stuck in the bore. Retract bolt slowly and remove fired cartridge case. Clear weapon and check for unburned powder grains in the receiver or bore and for a bullet stuck in the bore. Remove unburned powder or bullet from bore before resuming firing. If the bullet is stuck in bore, return the weapon to the armor.

a First (or maybe last) trigger pull may not fire more than one or two rounds. Quickly pull trigger again all the way to the rear and hold to get a full three-round burst. This is called "double squeezing" the trigger. This technique is often necessary if firing is continued after changing magazines or switching from SEMI to BURST.

b. To guarantee a three-round burst the first time you pull the trigger, follow these steps:

WARNING

Start with a clear weapon.

- (1) Place selector on BURST.
- (2) Pull trigger and hold it to the rear.
- (3) Pull charging handle to rear and let it go three times.
- (4) Let go of the trigger.
- (5) Pull bolt to rear, push in on the bottom portion of bolt catch thereby locking the bolt to the rear.

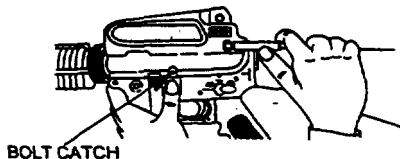

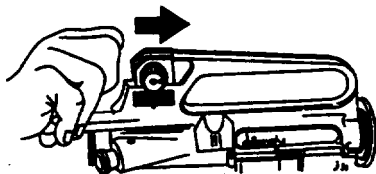
OPERATION (Cont)

(6) Slide the charging handle all the way forward.

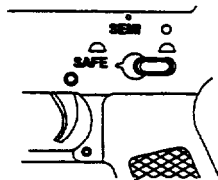

(7) Place selector on SAFE.

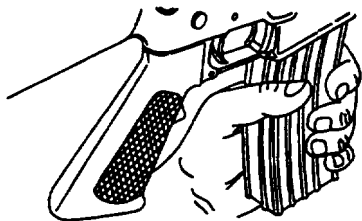

(8) Insert and seat a loaded magazine.

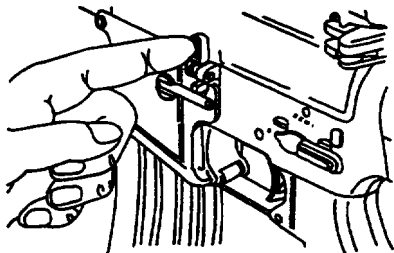

(9) Push on the upper portion of the bolt catch to allow the bolt to go forward.

OPERATION (Cont)**WARNING**

Your weapon is now loaded. Ensure it is pointed in a safe direction.

- (10) Placing the selector on BURST and pulling the trigger will give you a three-round burst.

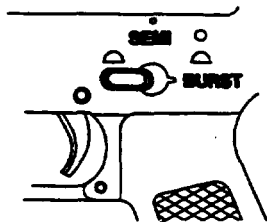
**NOTE**

If you release the trigger before all three rounds are fired, your next pull on the trigger will fire only the remaining rounds from the previous burst. Once you squeeze off a burst, keep the squeeze on until the three-round cycle is complete.

IMMEDIATE ACTION - If your weapon stops firing, perform the following immediate actions:

WARNING

If a noticeable difference in sound or recoil is experienced, STOP FIRING. Either condition could indicate an incomplete powder burn and/or a bullet stuck in the bore. Retract bolt slowly and remove fired cartridge case. Clear weapon and check for unburned powder grains in the receiver or bore and for a bullet stuck in the bore. Remove unburned powder or bullet from bore before resuming firing. If the bullet is stuck in bore, return the weapon to the armor.

1. Slap upward on magazine to make sure it is properly seated.

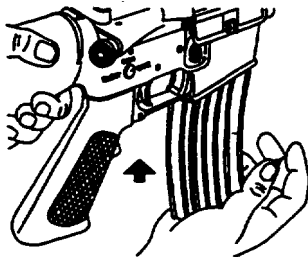

IMMEDIATE ACTION (Cont)**WARNING**

Do not load with a hot chamber.

2. Pull charging handle all the way back back. Observe ejection of case or cartridge. Check chamber for obstruction. If chamber is not clear, apply remedial action.

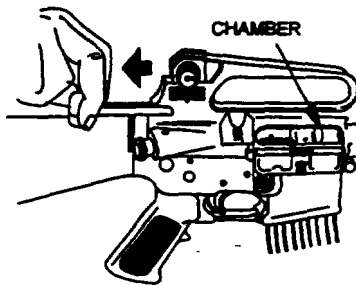

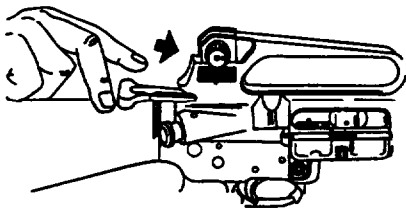

3. If cartridge or case is ejected or chamber is clear, Release charging handle to feed new round. Don't ride the charging handle forward.

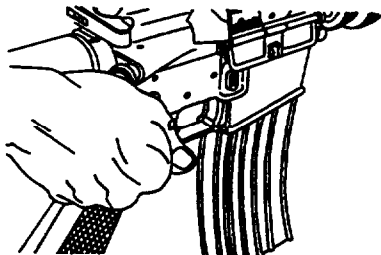

4. TAP forward assist.
5. Now FIRE. If it won't fire, look for trouble and apply remedial action.

REMEDIAL ACTION**WARNING**

If your weapon stops firing with a live round in the chamber of a hot barrel, remove the round fast. However, if you cannot remove it within 10 seconds, remove magazine and wait 15 minutes with the weapon pointing in a safe direction. This way you won't get hurt by possible round cooking off. Regardless, keep your face away from the ejection port while clearing a hot chamber.

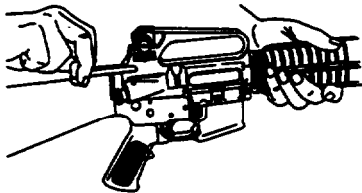

1. If your weapon still fails to fire after performing. Immediate Action. check again for jammed cartridge case.

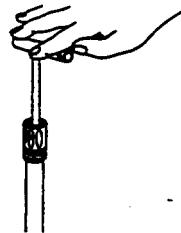

2. If a cartridge case is in the chamber, tap it out with a cleaning rod.

BULLET STUCK IN BORE

WARNING

If an audible 'POP' or reduced RECOIL is experienced during firing, immediately CEASE FIRE.

DO NOT APPLY IMMEDIATE ACTION.

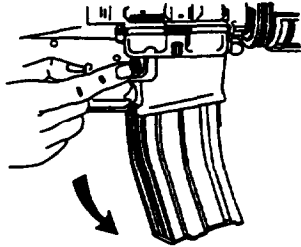

1. Remove the magazine.

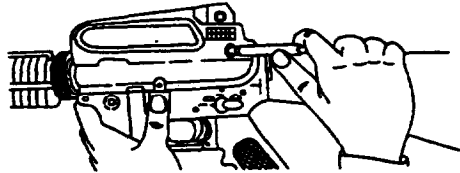

2. Lock the bolt to the rear.

BULLET STUCK IN BORE (Cont)

3. Place the selector lever on the "SAFE" position.
4. Visually inspect chamber or insert cleaning rod into the bore to ensure there is not a bullet stuck in the bore.
5. If a bullet is stuck in the barrel of the weapon, DO NOT attempt to remove it. Turn the weapon into the armor.

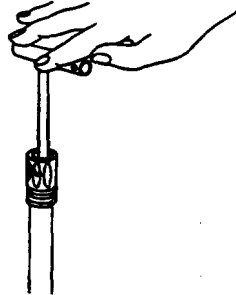

LOADING MAGAZINE

NOTE

The magazine may be loaded quickly using ten-round stripper clips and the magazine filler found in each bandoleer.

1. With the magazine filler in place, place a ten-round stripper clip in position. Using thumb pressure on the rear of the top cartridge, press down firmly until all ten rounds are below the feed lips of the magazine.

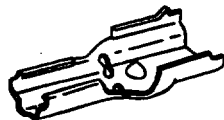
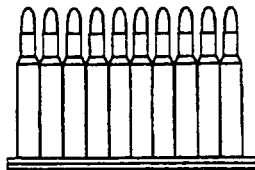

LOADING MAGAZINE (Cont)

2. Remove the empty stripper dip while holding the magazine filler in place.
3. Repeat until three ten round clips are loaded.
4. Remove magazine filler and retain it for future use.

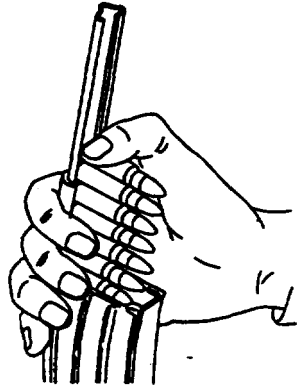

END OF TASK

NOTE

Removal of the muzzle cap prior to firing is recommended. Place it in your pocket for future use. However, it is not dangerous to fire the weapon with the muzzle cap installed.

EXTREME COLD CLIMATE - ARCTIC**CAUTION**

Be careful not to accidentally fire your weapon when inserting gloved fingers into trigger guard area.

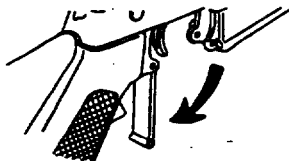
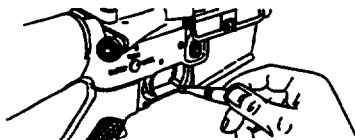

1. To operate the weapon in extreme cold, depress the trigger guard plunger and open the trigger guard to obtain easy access to the trigger when wearing Arctic mittens.

EXTREME COLD CLIMATE - ARCTIC (Cont)**NOTE**

Under extreme cold conditions, a small amount of CLP on moving parts can prevent weapon from firing. Ensure CLP is thoroughly removed from weapon and LAW applied prior to extreme cold operations.

2. Cleaning and lubrication should be accomplished inside a warm, room and the weapon should be at room temperature if possible.
 - a. Apply a light coat of LAW to all functional parts.
 - b. To prevent the condensation of moisture and freezing, keep the weapon covered when moving from a warm to a cold area to allow gradual cooling.
 - c. Always attempt to keep the weapon dry.

- d. Unload and hand function the weapon every 30 minutes to help prevent freezing of functional parts.
- e. Do not lay a warm weapon directly in snow or ice.
- f. When moving a cold weapon into a warm place, condensation (moisture) will form in and on your weapon. If possible, leave your weapon in a protected but cold area outside. When the weapon is brought inside a warm place, it should be disassembled and wiped dry several times as it reaches room temperature.
- g. Keep the insides of magazines and your ammo wiped dry. Moisture will freeze and cause malfunctions. Do not lube the ammo.
- h. The use of the muzzle cap, protective magazine bag, and an overall weapon cover will help protect your weapon. Use them whenever the tactical situation permits.
- i. For extended operations in extreme cold, have armor remove trigger guard.

HOT, WET CLIMATE -JUNGLE**NOTE**

Use CLP to clean and lube.

1. Perform normal maintenance as outlined in the PMCS table in WP 0006 00-4.
2. Clean and lube weapon more frequently. Inspect hidden surfaces of the bolt and carrier assembly, upper receiver and chamber/barrel extension (locking lugs), and the lower receiver and receiver extension assembly (buffer tube) for corrosion. Also pay close attention to the spring-loaded detents on the weapon.
3. To help prevent corrosion, remove handprints with a dry wiping rag. Then lubricate lightly with CLP.
4. Unload and check the inside of magazines frequently for corrosion and moisture. Wipe ammo dry before reloading.
5. Use magazine bag, muzzle cap, etc. for protection when the tactical situation permits.

HOT, DRY CLIMATE - DESERT

NOTE

Hot, dry climates are usually areas containing blowing sand and fine dust. Deserts can be hot during daylight hours and freezing during hours of darkness. Consequently, this harsh environment will severely tax your weapon as well as all other types of equipment. Your weapons continued operation will depend on your detailed cleaning and lubricating procedures.

1. Dust and sand will get into the weapon and magazines. This will cause malfunctions. Give the inside areas and functional parts of the weapon a thorough cleaning every day and after firing missions.
2. Corrosion is less likely to form on metal parts in a dry climate: therefore, lubrication should be applied to the internal working surfaces and functional parts only. Use light amounts of lubrication. Unload and dry ammo and inside of magazines daily. Do not lube magazines.

HOT, DRY CLIMATE - DESERT (Cont)

3. The use of overall weapon protection cover, muzzle cap, and spare magazine protective bags will help protect the weapon ammo from sand and dust. Use these items when the tactical situation permits.
4. Keep the bolt and ejection port cover closed, a magazine installed in the weapon, and muzzle cap on the muzzle to help keep out sand and dust.

HEAVY RAIN AND FORDING OPERATIONS - ALL CLIMATES

1. Perform maintenance in accordance with the appropriate climate conditions.
2. Always attempt to keep weapon dry.
3. Use weapon cover, muzzle cap, and protective bags to protect weapon, ammo, and magazines.
4. Always drain any water from barrel prior to firing. Dry the bore with a swab and cleaning rod if it is wet.

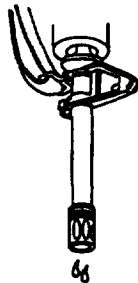
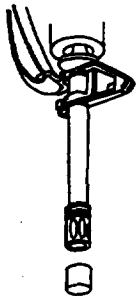
AFTER FORDING**WARNING**

Do not fire if water is present in barrel.

1. Remove muzzle cap.

2. Point the muzzle down and shake vigorously.

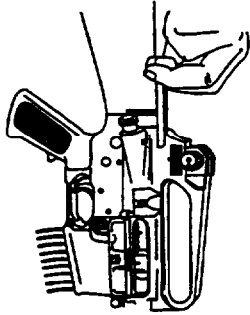

3. Pull charging handle 2 to 3 inches rearward end allow water to drain.

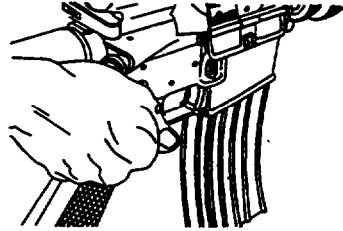

4. Release charging handle and strike forward assist to seat round end lock bolt.

AFTER FORDING (Cont)

5. Clear the drain hole in the stock with a pipe cleaner and drain.

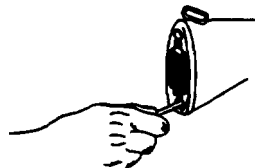
**AFTER SALT WATER OPERATIONS**

1. Clean your rear sight as soon as possible if it has salt water on it.
2. Wash your rear sight with fresh water from your canteen or some other source if you don't have time to dean it with CLP right away.

NUCLEAR, BIOLOGICAL, AND CHEMICAL (NBC) - General procedures can be found in FM 3-3, FM 3-4, FM 3-5. and FM 3-100.

END OF TASK

WARNING

Before starting functional check, be sure to clear the weapon. DO NOT squeeze the trigger until the weapon has been cleared. Inspect the chamber to ensure that it is empty and no ammunition is in position to be chambered.

1. Remove Magazine and Check Chamber.
2. Perform Functional Check.

- a. Place selector lever on SAFE: Pull charging handle to rear and release. Pull trigger. Hammer should not fall.

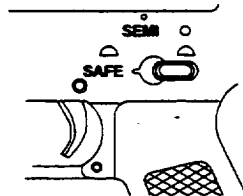

NOTE

Slow is defined as 1/4 to 1/2 the normal rate of bigger release.

- b. SEMI: Place selector lever on SEMI. Pull trigger. Hammer should fall. Hold trigger to the rear end charge the weapon. Release the trigger with a slow, smooth motion, until the trigger is fully forward (an audible click should be heard). Pull trigger. Hammer should fall.

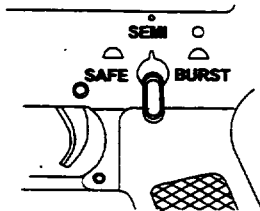

- c. BURST (M16A2, M16A4 and M4 Only):
M4 Only): Place selector lever on BURST. Charge weapon and squeeze trigger, hammer should fall. Hold trigger to the rear, pull charging handle to the rear and release it three times. Release trigger. Squeeze trigger. Hammer should fall.

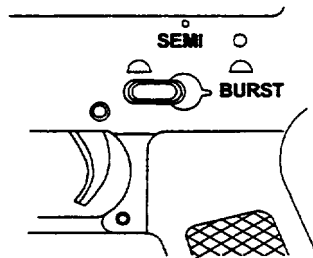

- d. AUTO (M16A3 and M4A1 Only):
Pull the charging handle to the rear, charging the weapon. Squeeze the trigger; hammer should fall. Hold the trigger to the rear and cock the weapon again. Fully release the trigger then squeeze it again. The hammer should not fall because it should have fallen when the bolt was allowed to move forward during the chambering and locking sequences.

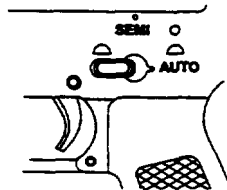

END OF TASK

ADJUSTABLE REAR SIGHT - Two apertures for range

SHORT RANGE OR AT NIGHT -This "larger aperture is used for 0-200 meters range. As shown, the sight is set for 0-200 meters. This larger aperture is only used when the rear sight is all the way down. In other words, the 300-meter mark is aligned with the mark on the left side of the receiver. Useful for moving targets.

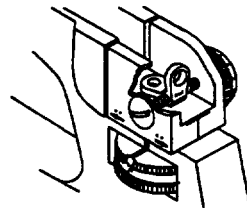
**(0-200 METERS)**

NORMAL RANGE -The aperture is unmarked and used for most firing situations. It is used in conjunction with the elevation knob for 300, 400, 500, 600, 700, and 800-meter targets.

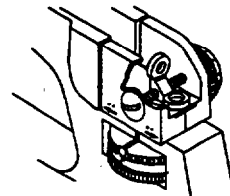
**(300-800 METERS M16A2/M16A3)
(300-600 METERS M4/M4A1/
M16A4)**

BATTLESIGHT ZERO

When battlesights are on your weapon:

- a. The front sight post and rear sight windage knob are adjusted so you can hit your point of aim at 300 meters.
- b. The unmarked aperture must be in the up position.
- c. The 300-meter mark is aligned with the mark on the left side of the receiver. This will read 8/3 for the M16A2/M16A3 and 6/3 for the M4/M4A1/M16A4.

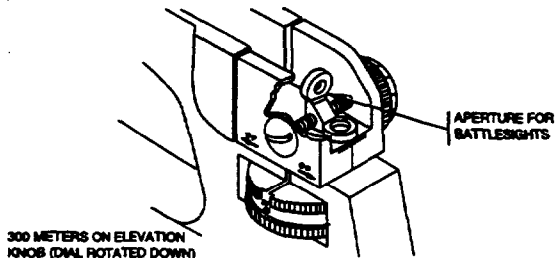

BATTLESIGHT ZEROING ADJUSTMENTS

1. During zeroing procedures, only the front sight post and windage knob are adjusted to move the strike of the bullet on the target.
2. If you are zeroing on a 25-meter range, the rear sight elevation knob is adjusted in accordance to whichever weapon you are using.
3. Detailed zeroing procedures are on the target and the following pages.

FRONT SIGHT - The front sight post is moved up or down when zeroing the weapon. **Once the weapon is zeroed, the front sight post should not be moved.**

To adjust elevation, depress detent and rotate post. To raise strike of bullet, rotate post in the direction of arrow marked UP. Reverse the direction of rotation to lower strike of bullet. Each graduation (notch) moves the point of impact of bullet as indicated.

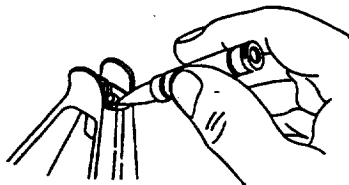

FOR ELEVATION (per click)

IMPACT	DISTANCE
0.9 cm (3/8 in.)	25 meters (M16A2/M16A3/M16A4)
3.5 cm (1 3/8 in.)	100 meters (M16A2/M16A3/M16A4)
7.0 cm (2 3/4 in.)	200 meters (M16A2/M16A3/M16A4)

FOR WINDAGE KNOB (per click)

IMPACT	DISTANCE
0.3 cm (1/8 in.)	25 meters (M16A2/M16A3/M16A4)
1.25 cm (1/2 in.)	100 meters (M16A2/M16A3/M16A4)
2.60 cm (1 in.)	200 meters (M16A2/M16A3/M16A4)
3.8 cm (1 1/2 in.)	300 meters (M16A2/M16A3/M16A4)
5.0 cm (2 in.)	400 meters (M16A2/M16A3/M16A4)
6.3 cm (2 Min.)	500 meters (M16A2/M16A3/M16A4)
7.8 cm (3 in.)	600 meters (M16A2/M16A3/M16A4)
8.8 cm (3 1/2 in.)	700 meters (M16A2/M16A3/M16A4)
10.0 cm (4 in.)	800 meters (M16A2/M16A3/M16A4)

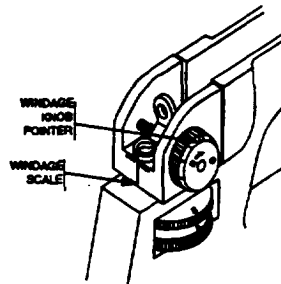

FOR ELEVATION (per click)

IMPACT	DISTANCE
1.2 cm (1/2 in.)	25 meters (M4/MA1)
4.8 cm (1 7/8 in.)	100 meters (M4/M4A1)
9.6 cm (3 3/4 in.)	200 meters (M4/M4A1)

FOR WINDAGE KNOB (per click)

IMPACT	DISTANCE
0.5 cm (3/16 in.)	25 meters (M4/M4A1)
1.9 cm (3/4 in.)	100 meters (M4/MA1)
4.8 cm (1 1/2 in.)	200 meters (M4/M4A1)
5.7 cm (2 1/4 in.)	300 meters (M4/M4A1)
7.6 cm (3 in.)	400 meters (M4/M4A1)
9.5 cm (3 3/4 in.)	500 meters (M4/M4A1)
11.4 cm (4 1/2 in.)	600 meters (M4/M4A1)

BATTLESIGHT ZEROING ADJUSTMENTS (Cont)

To remember your correct battlesight zero windage, note location of windage scale and windage knob pointer (heavy mark on outside of knob).

Do not center rear sight aperture for inspections. Keep your correct battlesight zero windage on your weapon at all times.

By following the steps below and establishing a zero at 25 meters, your sights will be set with a 300-meter battlesight.

NOTE

Do not move front sight post at this time. It was set at the factory or by a previous shooter and should be very close to your zero.

Center the rear sight aperture by turning the windage knob left or right. (This is called mechanical zero windage.)

1. Position a 25 Meter Zero Target; NSN 6920-01-395-2949, 25 meters from the firing line. The rifle target is on one side and the carbine target on the other.
2. The unmarked long range aperture should be up.
3. Rotate elevation knob in the down direction (counter-clockwise). The elevation knob should stop on the 300-meter mark (8/3) M16A2/M16A3 rifles and (6/3) M16A4/M4/M4A. The rear sight should be all the way down on the last whole "click" before it bottoms out. This is called mechanical zero elevation for the rear sight. If your range scale will not line up in the above manner, an armor will be required to adjust the range scale for you.
4. Now rotate the elevation knob clockwise (up) one click past the 300 meter setting for the M16A2/M16A3 rifle, clockwise (up) two clicks for the M16A4 rifle. The elevation knob should remain aligned on the 300 meter setting for the M4/M4A1 carbine. Any further corrections required in elevation are made to the front sight post only.
5. Aim at target center. Adjust front sight and rear windage to move shot group center as close as possible to the white dot in the center of target.

BATTLESIGHT ZEROING ADJUSTMENTS (Cont)

6. If your shot group is not in the center of the bull's eye, use the squares on the target sheet to calculate the required "clicks" necessary to move your next shot group into the bull's-eye. (Remember that any changes in elevation are made by moving the front sight post.) The squares are numbered around the edges of the target to equal the number of clicks required to move the shot group to the bull's eye.
7. In order to raise your next shot group, rotate the front sight post clockwise. (One click will move the strike of the bullet one vertical square on the target sheet) In order to lower your next shot group, rotate the front sight post counterclockwise (one click, as above, equals one square). Changes in windage are made with the windage knob. (Three clicks will move the strike of the bullet one horizontal square on the target sheet). In order to move the shot group to the left, turn the windage knob counterclockwise. In order to move the shot group to the right, turn the windage knob clockwise.
8. Carefully aim and fire another group at the center of the target bull's eye.
9. Repeat Steps 6 through 8, if required.

10. If your group is centered, your weapon is now zeroed.

RIFLES ONLY

11. Rotate the rear sight elevation knob counterclockwise (down) one click to the 300 meter setting for the M16A2/M16A3 Rifle, down two clicks to the 300-meter setting for the M16A4 Rifle. The weapon is zeroed for 300 meters.

END OF TASK

INTRODUCTION

Table 1 lists common malfunctions that you may find with your equipment. Perform the tests, inspections, and corrective actions in the order they appear in the table.

This table cannot list all the malfunctions that may occur, all tests and inspections needed to find the fault, or all the corrective actions needed to correct the fault. If the equipment malfunction is not listed or actions listed do not correct the fault, notify your armor.

THIS WORK PACKAGE COVERS: Troubleshooting**INITIAL SETUP:** Operator

Table 1. TROUBLESHOOTING

MALFUNCTION	TEST OR INSPECTION	CORRECTIVE ACTION
Won't Fire	tight indentation on the primer Selector lever on SAFE. Improper assembly of firing pin. Too much oil in firing pin recess. Defective ammo. Too much carbon on firing pin or in firing pin recess.	Notify unit armor. Put in fire position. Assemble correctly retaining pin goes in back of large shoulder of firing pin. wipe out with pipe cleaner. Remove and discard. Clean.

Table 1. TROUBLESHOOTING (Cont)

MALFUNCTION	TEST OR INSPECTION	CORRECTIVE ACTION
Bolt Won't Unlock	Dirty or burred bolt.	Notify NCO or your unit ARMOR.
Won't Feed	Dirty or corroded ammo.	Clean.
	Dirty magazine.	Clean.
	Defective magazine.	Replace.
	Too many rounds in magazine.	Take out excess.
	Action of buffer assembly is restricted.	Take out buffer and spring and clean.
	Magazine not fully seated.	Tap on magazine or adjust magazine catch.
Double Feed	Defective magazine.	Replace.

Table 1. TROUBLESHOOTING (Cont)

MALFUNCTION	TEST OR INSPECTION	CORRECTIVE ACTION
Double Feed	Defective magazine.	Replace.
Won't Chamber	Dirty or corroded ammo. Damaged ammo. Carbon in chamber or on gas tube.	Clean or replace. Replace. clean.
Won't lock	Dirt, corrosion, or carbon build-up in barrel or bolt locking lugs.	Clean lugs.
Won't Extract	Frozen extractor. Broken extractor spring. Restricted buffer assembly.	Remove and clean. See your ARMOR. Remove and clean.

Table 1. TROUBLESHOOTING (Cont)

MALFUNCTION	TEST OR INSPECTION	CORRECTIVE ACTION
Won't Extract	Restricted movement of bolt carrier group.	Remove, clean, and lube. (Before putting bolt back in, make sure gas tube fits into carrier key and that the carrier moves freely.
	Dirty or corroded ammo.	Remove and clean. Push out stuck cartridge with cleaning rod.
	Dirty chamber.	Clean Chamber.
Short Recoil	Gaps in bolt rings (not staggered).	Stagger ring gaps.

Table 1. TROUBLESHOOTING (Cont)

MALFUNCTION	TEST OR INSPECTION	CORRECTIVE ACTION	
Short Recoil (cont)	Ming or broken rings. Three rings required.	Notify armor.	
	Carbon or dirt in carrier key or on outside of gas tube.	Clean.	
	Pipe cleaner stuck inside carrier key.	Notify armor.	
	Bolt Fails to Lock After Last Round	Dirty or corroded bolt latch.	Clean.
	Faulty magazine.	Replace.	
	Needs oil.	Lubricate.	
Selector Lever Binds	Dirt or sand under trigger.	Clean.	

Table 1. TROUBLESHOOTING (Cont)

MALFUNCTION	TEST OR INSPECTION	CORRECTIVE ACTION
Bolt Carrier 'Hung Up'	<p style="text-align: center;">WARNING</p> <p style="text-align: center;">Keep clear of muzzle.</p> <p>Round jammed between bolt and charging handle and/or double feed.</p> <p style="text-align: center;">CAUTION</p> <p style="text-align: center;">If round is removed, bolt is under spring pressure.</p>	Remove magazine. Remove rounds, if not removed notify armor.

END OF TASK

CHAPTER 3

MAINTENANCE INSTRUCTIONS

WARNING

To be considered SAFE before DISASSEMBLY INSTRUCTIONS, cleaning, inspecting, transporting, or storing, the weapon must be cleared.

1. Clear your weapon. Refer to WP 0008 00.
2. Remove sling.

CAUTION

Do not use a screwdriver or any other tool when removing the handguards. Doing so may damage the handguard and/or slip ring.

3. Place the weapon on the buttstock and press down on the slip ring with both hands.
4. Have another person pull the handguards free (the 'Buddy System").

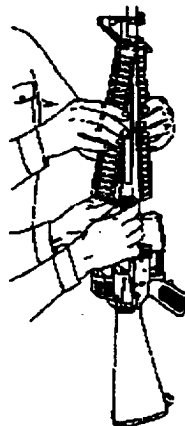

NOTE

The round handguards are identical and can be interchanged (top or bottom).

5. Install the handguards using the same system.

CAUTION

Only use hand pressure to disengage the pivot and takedown pins. Force other than hand pressure may cause damage to the weapon and replacement of the weapon would be required. Only push the pivot and takedown pins far enough to disengage the upper receiver from the lower receiver.

6. Push takedown pin as far as it will go. Pivot upper receiver from lower receiver.

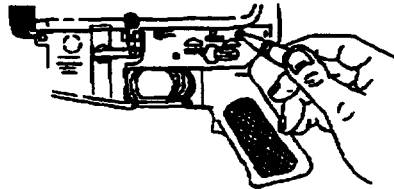

7. Push receiver pivot pin as far as it will go.
8. Separate upper and lower receivers.

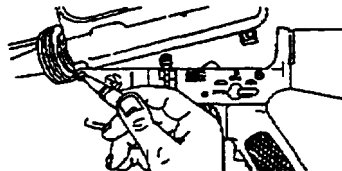

CAUTION

Do not fully remove the round nuts from the threaded studs. The threaded studs are flared on the end to prohibit removal. However, if the nuts are inadvertently removed, they may be reinstalled.

9. If your weapon is equipped with a removable carrying handle assembly, loosen the round nuts on the left side of the carrying handle, approximately 4 turns. Loosen the clamping bar from the left side of the upper receiver and lift off the carrying handle assembly.

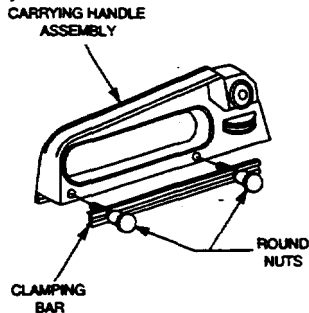

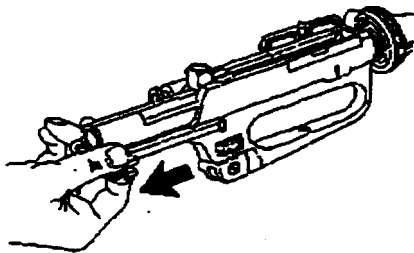

10. Pull back charging handle and bolt carrier.

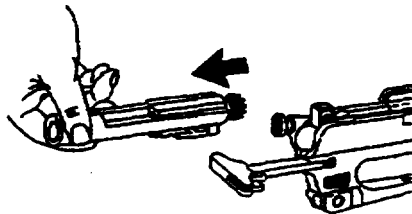

11. Remove bolt carrier and bolt.

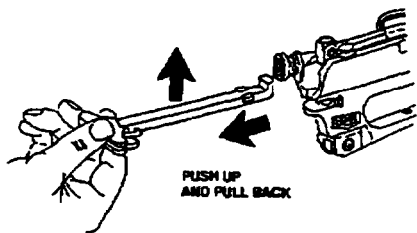

12. Remove charging handle.

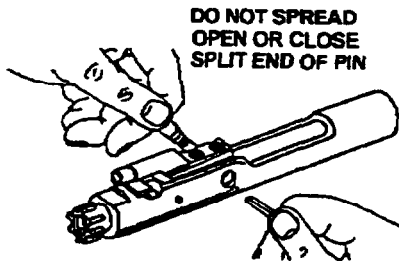

13. Remove firing pin retaining pin.

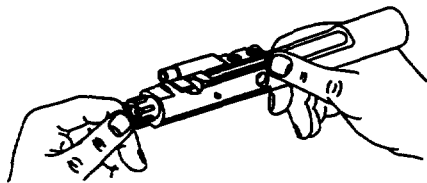

14. Push in bolt assembly to locked position.

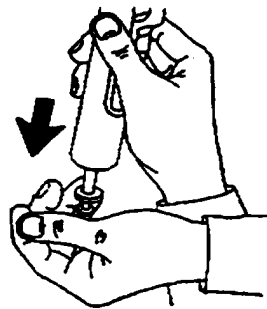

15. Drop firing pin out rear of bolt carrier.

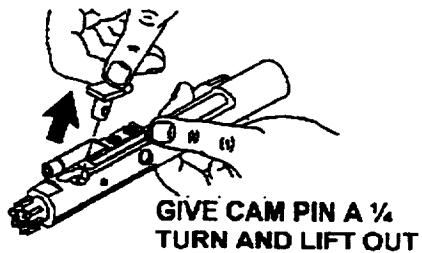

16. Remove bolt cam pin.

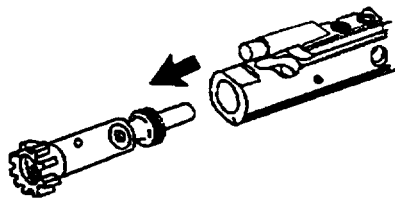

17. Remove bolt assembly from carrier.

NOTE

Disassemble using steps 18-23 only when dirty or damaged.

Press rear of extractor to check spring function. See your Armor if spring is weak.

18. Remove extractor pin.

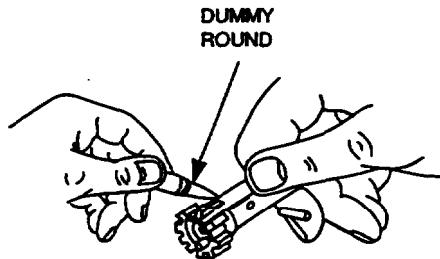

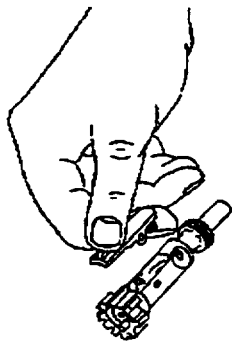

NOTE

Do not separate spring assembly from extractor.

19. Remove extractor and spring assembly.

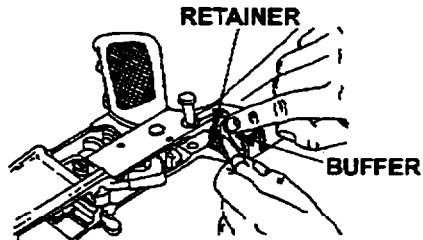

20. Press in buffer, depress retainer, and release buffer.

21. Remove buffer and action spring.

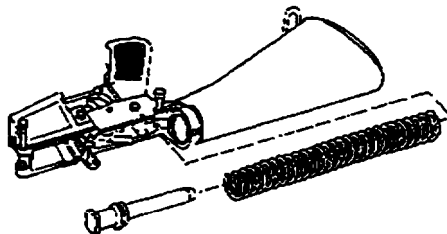

CARBINE ONLY

22. Fully extend buttstock assembly.

23. Grasp the lock release lever in the area of the retaining nut, pull downward, and slide buttstock to the rear to separate the buttstock assembly from the lower receiver extension.

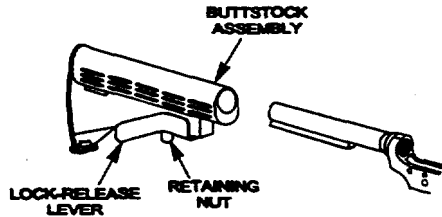

NOTE

No further disassembly allowed.

END OF TASK

WARNING

Before cleaning be sure to clear the weapon.

GENERAL**NOTE**

Wherever the term CLP or the words lube or lubricant are cited in this TM, it is to be interpreted to mean that CLP, LSA, or LAW can be utilized as applicable. DO NOT mix lubricants on the same weapon. The weapon must be thoroughly cleaned during change from one lubricant to another. Dry cleaning solvent (SD) is recommended for cleaning during change from one lubricant to another.

1. With the weapon disassembled, thoroughly clean, inspect, and lube.
2. Always shake CLP before use.
3. After firing, clean your weapon according to instructions. Wipe dry and lube according to lubrication instructions (WP 0016 00).

GENERAL (Cont)

4. Cleaning materials (swabs, pipe cleaners, and CLP) are expendable items that are available from supply.

CAUTION

Don't mix up the parts of your weapon with those of your buddy.

BORE

The bore of your weapon has lands and grooves called rifling. Rifling makes the bullet spin very fast as it moves down the bore and down range. Because it twists so quickly, it is difficult to push a new, stiff bore brush through the bore. You will find it easier to pull your bore brush through the bore. Also, because the brush will clean better if the bristles follow the grooves (called tracking), you want the bore brush to be allowed to turn as you pull it through.

This is how you do it:

1. Attach three rod sections together.
2. Swab out the bore with a patch moistened with CLP or rifle bore cleaner (RBC).
3. Attach the bore brush. When using bore brush, don't reverse direction while in bore.

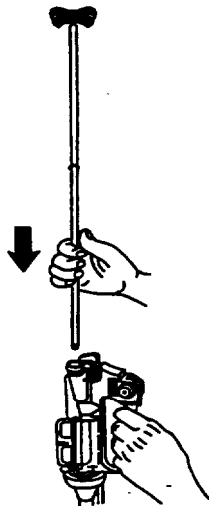

BORE (Cont)

4. Point muzzle down. Hold the upper receiver in one hand while inserting the end of the rod without the brush into the chamber. Let the rod fall straight through the bore. About 2-3 inches will be sticking out of the muzzle at this point.
5. Attach the handle section of the cleaning rod to the end of the rod sticking out of the muzzle.
6. Pull the brush through the bore and out the muzzle.
7. After one pull, take off the handle section and repeat the process.

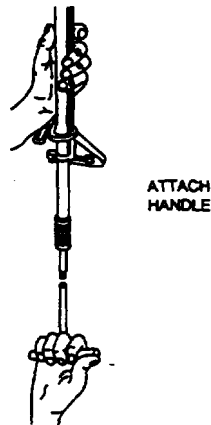

8. Send a patch through the bore once in a while to help clean out the crud that the brush is getting loose. Replace the bore brush with the rod tip (patch holder) and a wet patch. Drop it through. You won't need to attach the handle to pull only a patch through.

UPPER RECEIVER - Clean with CLP:

- a. All areas of Powder Fouling, Corrosion, Dirt, and Rust
- b. Sore and Chamber.
- c. Locking Lugs
- d. Gas Tube

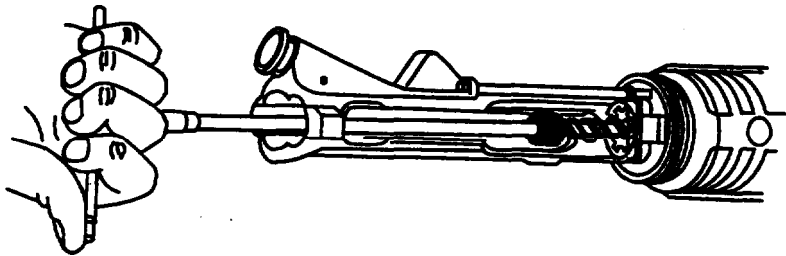
UPPER RECEIVER - (Cont)

- e. Install chamber brush on cleaning rod. Dip in CLP and insert in chamber and locking lugs. Clean by pushing and twisting cleaning rod.

NOTE

Gas tubes will discolor from heat Do not attempt to remove discoloration.

Use a worn out bore brush to perform the following step. This procedure ruins the bore brush.

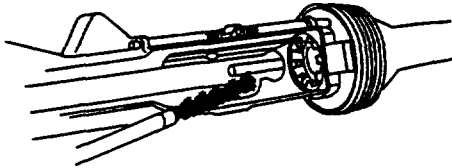

- f. Use a bore brush to clean outside surface of protruding gas tube (get sides and bottom from bottom of upper receiver).

BOLT CARRIER ASSEMBLY - Clean with CLP:

- a. Clean carbon and oil from firing pin, firing pin recess and all surfaces of bolt/bolt carrier with dry swabs.
- b. Clean bolt carrier key with worn brush.
- c. Clean firing pin hole with pipe cleaner.

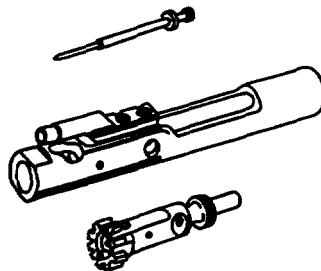

NOTE

Use well worn bore brush only.

- d. Carbon deposits and dirt from locking lugs
- e. Areas behind bolt ring and under lip of extractor

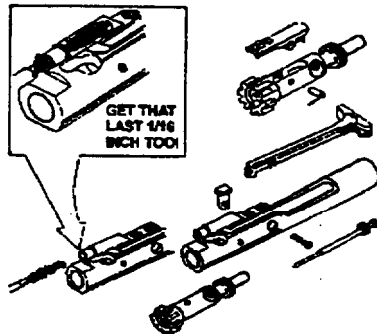

LOWER RECEIVER AND BUTTSTOCK ASSEMBLY.**CAUTION**

Do not use wire brush or any type of abrasive material to clean aluminum surfaces.

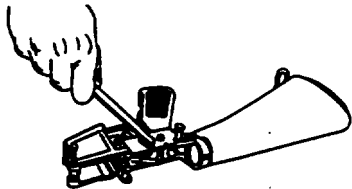

- a. Wipe dirt from trigger with a swab.
- b. Use a swab dipped in CLP and cleaning brush to clean powder fouling, corrosion, and dirt from outside parts of lower receiver and extension assembly.

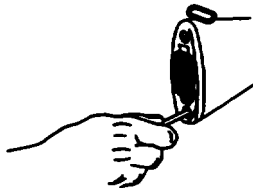

- c. Use pipe cleaner to clean buttstock screw drain hole.

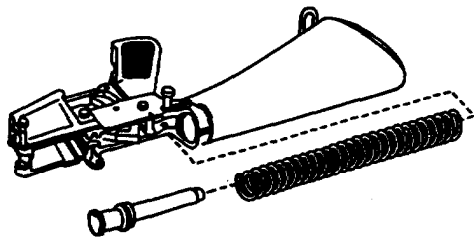

- d. Clean buffer assembly, spring, and inside lower receiver and buffer tube with swab dipped in CLP. Wipe dry.

EJECTOR

- a. Place a few drops of CLP around the ejector to form a puddle.

HOOK CASE UNDER EXTRACTOR
AND ROCK BACK AND FORTH
AGAINST EJECTOR.

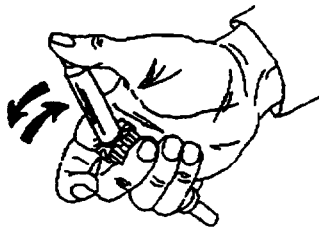

- b. Take a fired or dummy case and place it under the lip of the tractor. With a rocking motion, press the case down against the ejector. Since the ejector is spring loaded, some resistance will be felt. Press on the case until it stops against the bolt face. Ease off with your thumb slightly and press down again. Repeat several times. Replace the CLP frequently. Once the spring action of the ejector is smooth and strong, dry off any excess.

**HOOK CASE UNDER EXTRACTOR
AND ROCK BACK AND FORTH
AGAINST EJECTOR.**

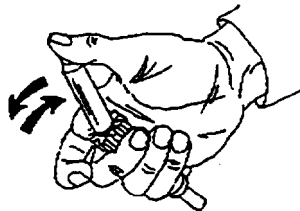

BUTTSTOCK AND PISTOL GRIP**NOTE**

Buttstock may be used for storage of cleaning gear.

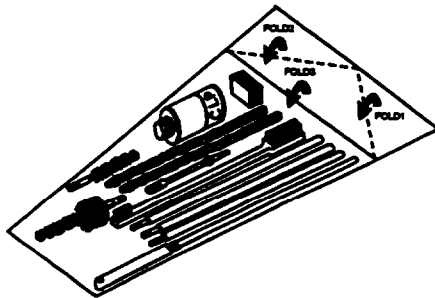

END OF TASK

**INSPECT BEFORE LUBRICATING -
UPPER RECEIVER AND BARREL ASSEMBLY****WARNING**

DO NOT interchange bolts between weapons.

1. Inspect handguards (1) for cracks, broken front or rear tabs and loose heat shields.
2. Inspect front sight post (2) for straightness and check depression of the front detent.
3. Inspect compensator (3) for looseness.
4. Inspect barrel (4) for straightness, cracks or burrs.
5. Inspect charging handle (5) for cracks bends or breaks.
6. Inspect rear sight assembly (6) for the capability to adjust windage and elevation and the spring should retain the short range or long range sight in position.
7. Inspect gas tube (7) for bends or retention to barrel.

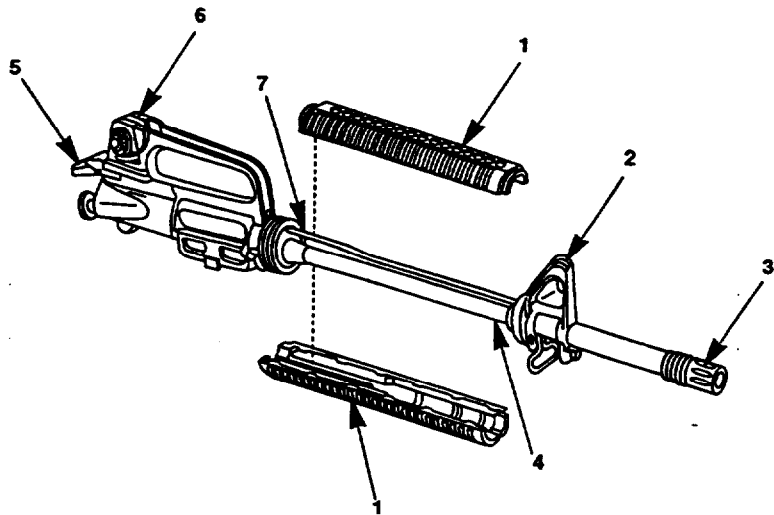

**INSPECT BEFORE LUBRICATING -(Cont)
BOLT AND BOLT CARRIER ASSEMBLY**

1. Inspect bolt cam pin (1) for cracking or chipping.
2. Inspect firing pin (2) for bends, cracks or sharp or blunted tip.
3. Inspect for missing or broken gas rings (3).
4. Inspect bolt cam pin area (4) for cracking or chipping.
5. Inspect locking lugs (5) for cracking or chipping. Inspect bolt face (6) for excessive pitting.
6. Inspect extractor assembly (7) for missing extractor spring assembly with insert and for chipped or broken edges on the lip which engages the cartridge rim.
7. Inspect firing pin retaining pin (8) to determine if bent or badly worn.
8. Inspect bolt carrier for loose bolt carrier key (9).
9. Inspect for cracking or chipping in cam pin hole area (10).

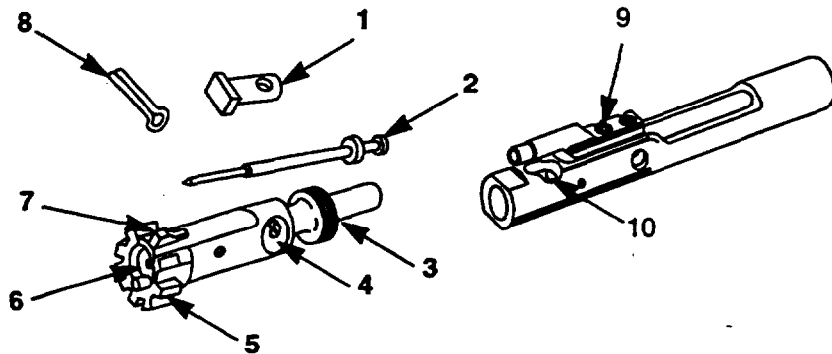

**INSPECT BEFORE LUBRICATING - (Cont)
LOWER RECEIVER AND BUTTSTOCK ASSEMBLY**

1. Inspect buffer (1) for cracks or damage.
2. Inspect buffer spring (2) for kinks.
3. Inspect buttsock (3) for broken buttplate or cracks.
4. Inspect for bent or broken selector lever (4).
5. Inspect rifle grips (5) for cracks or damage.
6. Inspect for broken or bent trigger (6).
7. Visually inspect the inside parts of the lower receiver (7) for broken or missing parts.

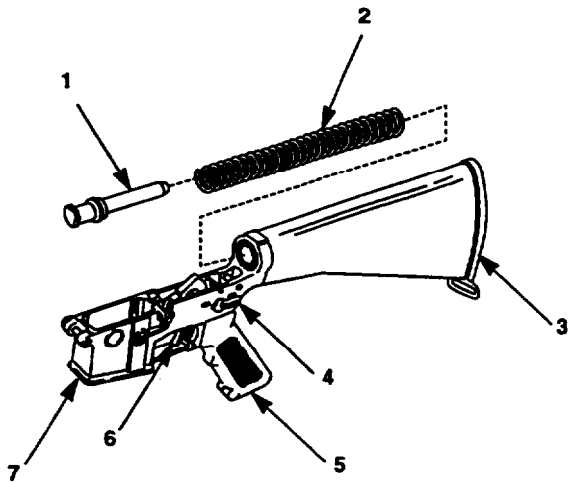

END OF TASK

CLP - CLEANER, LUBRICANT AND PRESERVATIVE

Use CLP as follows:

- a. Always shake bottle well before use.
- b. Place a few drops on a patch or rag.
- c. Clean your weapon with these patches and rags until they come out clean.
- d. Take a patch or rag and apply a fresh, light coat.

NOTE

Don't 'dry clean' your weapon. DO NOT use hot water or other solvents or you will wash away the Teflon lubricant that has been building up as a result of your using CLP. If CLP is not used, RBC may be used to remove carbon within the bore. Dry cleaning solvent may be used to completely remove lubricants. For example, when moving to extreme cold weather operations, to remove traces of CLP before applying LAW.

NOTE

Wherever the term CLP or the words lube or lubricant are cited in this TM, it is to be interpreted to mean that CLP, LSA, or LAW can be utilized as applicable. The following constraints must be adhered to (1) Under all but the coldest arctic conditions, LSA or CLP are the lubricants to use on your weapon. Either may be used at -10°F or above. However, do not use both on the same weapon at the same time. (2) LAW is the lubricant to use during cold arctic conditions, +10°F and below. (3) Any of the lubricants may be used from -10°F to +10°F. (4) Do not mix lubricants on the same weapon. The weapon must be thoroughly cleaned during change from one lubricant to another. Dry cleaning solvent (SD) is recommended for cleaning for cleaning during change from one lubricant to another.

LUBE GUIDE

Under all but the coldest Arctic conditions, CLP or LSA are the lubricants to use on your weapon. Remember to remove excessive lubricant from the bore and chamber before firing.

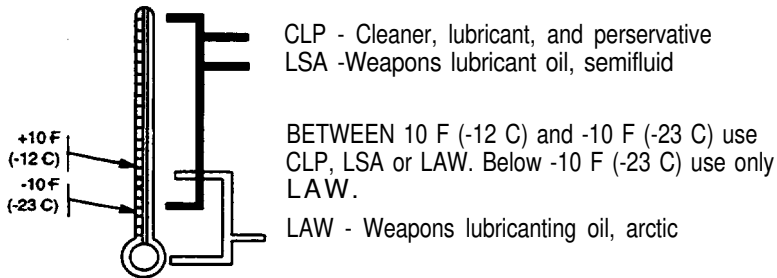

Lightly Lubed - A film of lubricant barely visible to the eye.

Generously Lubed - Heavy enough so that it can be spread with the finger.

LUBRICATING UPPER RECEIVER

Lightly lube inside of upper receiver, bore and chamber, outer surfaces of barrel and front sight, and surfaces under handguard. Depress front sight detent and apply one drop lube to front sight detent. Depress several times to work lube into the spring.

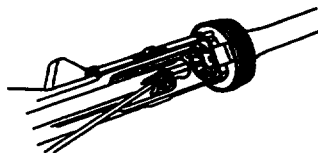
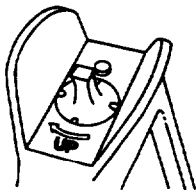

Be Sure to Lube Locking Lugs.

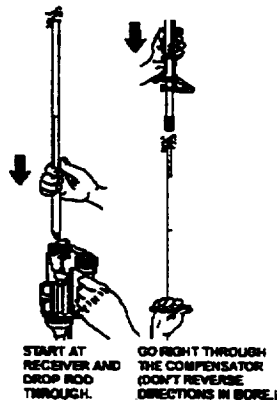

LUBRICATING PROCEDURES FOR M4, M4A1 AND M16A4 UPPER RECEIVER AND CARRYING HANDLE

1. Apply a drop or two of lubricant to both threaded studs.
2. Lightly lube the clamping bar and both round nuts.
3. Lightly lube the mating surfaces of the carrying handle assembly and upper receiver.

NOTE

Do not switch carrying handles between weapons.
Switching handles may change your weapons zero.

BOLT CARRIER ASSEMBLY

Lightly lubricate firing pin and firing pin recess in bolt

1. Place one drop CLP in carrier key.
2. Generously lube outside of these parts.
Make certain to get cam pin area, bolt rings, and outside of the bolt body. Put a light coat on extractor and pin.

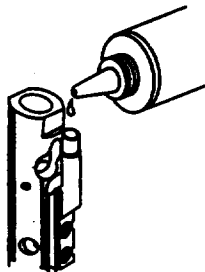

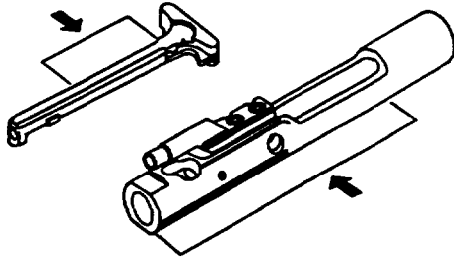

3. Lightly lube charging handle and inner and outer surfaces of bolt carrier. Generously lube slide and cam pin area of bolt carrier.

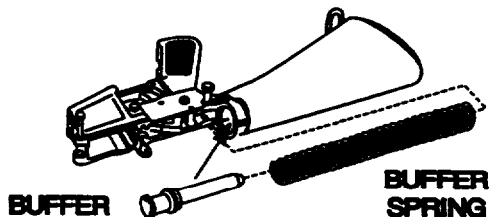
LUBRICATING LOWER RECEIVER ASSEMBLY

1. Lightly lube inside buffer tube.
2. Generously lube takedown and pivot pins and detents. Also lightly lube all moving parts inside lower receiver and their pins.

ADJUSTABLE REAR SIGHT

NOTE

Make a note of how far you move the sight so it can be returned to the original position at completion of this task.

1. Use one drop of lube and rotate these parts to ensure lubricant is spread evenly above and below:
 - a. Elevation knob
 - b. Elevation screw shaft
 - c. Windage knob
 - d. Windage screw
 - e. Detent holes
 - f. Aperture (flip up and down)

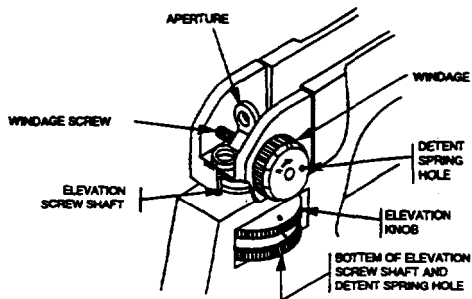

ADJUSTABLE REAR SIGHT (Cont)

2. Elevation Screw Shaft. Also lube from inside the upper receiver as follows:
 - a. For M16A2 and M16A3 turn upper receiver upside down and remove charging handle.
 - b. For M4, M4A1 and M16A4, remove carrying handle.
 - c. Put two or three drops around the bottom edge of the elevation screw shaft and in elevation detent spring hole.
 - d. Rotate the elevation dial as far as possible a few times while keeping upper receiver upside down.

AFTER LUBING REAR SIGHT

1. Reset your correct zero windage and your battlesight zero.
2. Notice the rear sight comes down when the “3” is aligned with the mark on the left side of the receiver.
3. You will feel a ‘click” when the “3” first lines up with the mark.
4. Carry your weapon with the “3” aligned with the mark
5. Keep the sight on 300 meters to keep dirt and water out of sight mechanism and protect the sight from damage.

END OF TASK

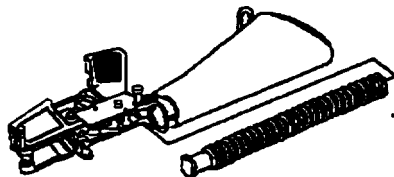
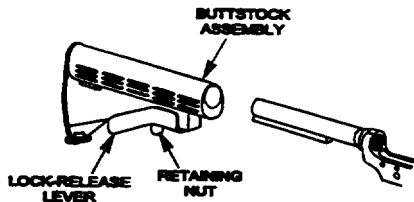

1. Grasp the lock release lever in the area of the retaining nut and pull to reinstall the buttstock assembly onto the lower receiver extension.
2. Insert buffer spring and buffer.

NOTE

Be sure not to lose extractor spring and rubber insert.

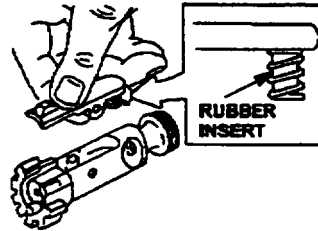
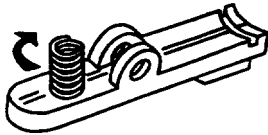

3. The large end of extractor Spring assembly in the extractor and seat it by pushing and turning clockwise.

4. Insert extractor assembly into bolt

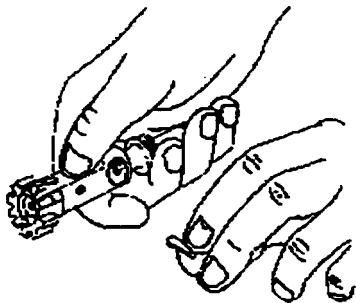

5. Install extractor pin.

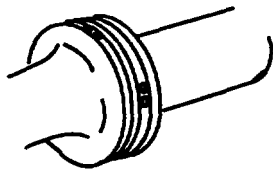

NOTE

Stagger ring gaps to stop gas loss.

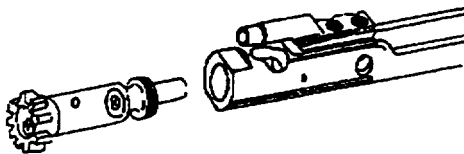

WARNING

Don't switch bolts between

6. Slide bolt into bolt carrier.

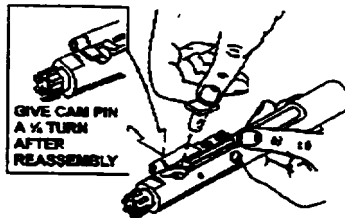

WARNING

Be sure the cam pin is installed in the bolt carrier assembly. If it isn't, your weapon can still fire and will explode.

7. Insert bolt cam pin.-

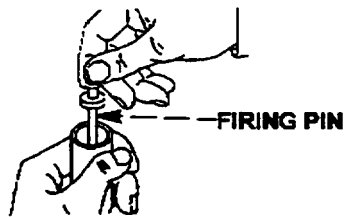

8. Drop in and seat firing pin.

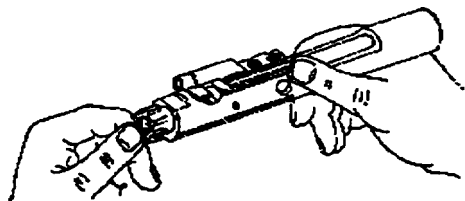

9. Pull bolt out.

10. Insert firing pin retaining pin.

NOTE

Firing pin should not fall out when bolt carrier assembly is turned upside down.

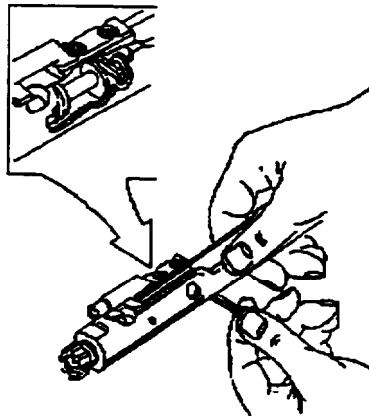

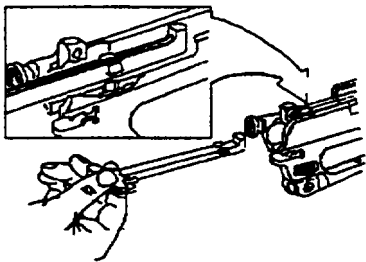

11. Insert charging handle part way.

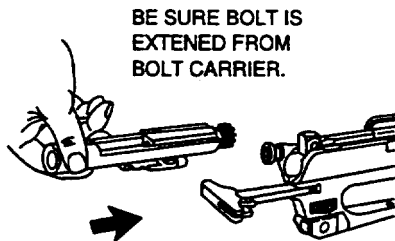

12. Slide in bolt carrier assembly.

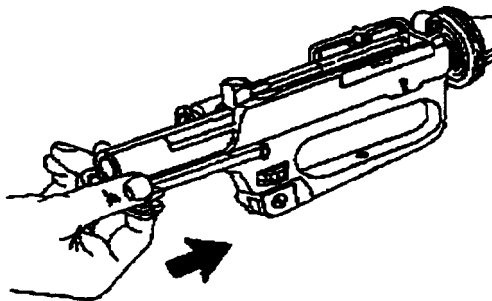

13. Push charging handle and bolt carrier assembly together into upper receiver until fully seated.

M4, M4A1, AND M16A4

CAUTION

Should the round nuts and the clamping bar be inadvertently removed, the clamping bar must be reinstalled on the threaded studs in a manner not to protrude past the front of the carrying handle. The round nuts should be reinstalled on the threaded studs.

NOTE

DO NOT ATTEMPT to reflare the end of the threaded stud if the nuts have been **removed**.

14. The carrying handle assembly should be reinstalled with the front stud centered into the forward notch in the front of the upper receiver mounting surface. Holding the carrying handle assembly flat against the top of the upper receiver, slide the damping bar against the receiver with the lower edge underneath the slotted portion. Using finger pressure only, firmly tighten both round nuts.

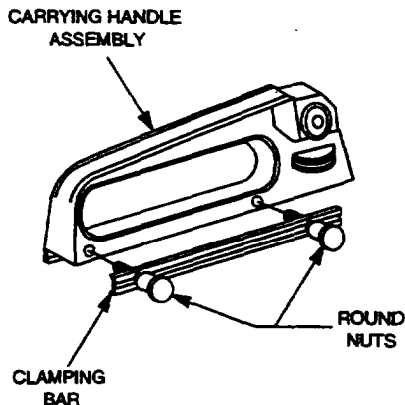

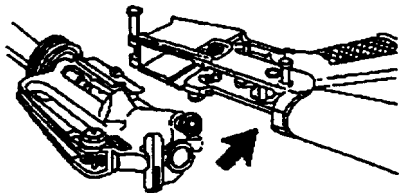

15. Join upper and lower receivers.

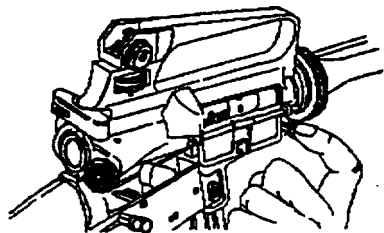

16. Engage receiver pivot pin.

CAUTION

Selector lever must be on SAFE or SEMI before closing upper receiver.

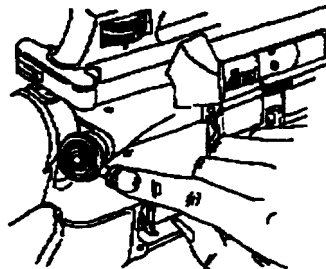
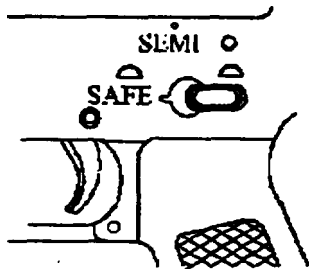

17. Close upper and lower receiver assembly. Push in takedown pin.

18. Place the weapon on the buttstock and press down on the slip ring with both hands.
19. Have your partner install one handguard on top and the other on the bottom (the "Buddy System").
20. Install sling

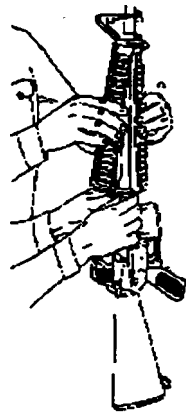

MAGAZINE DISASSEMBLY**WARNING**

When disassembling, turn magazine away from face, spring is under compression.

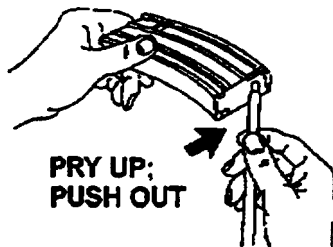

1. Release base catch with end of a cleaning rod.

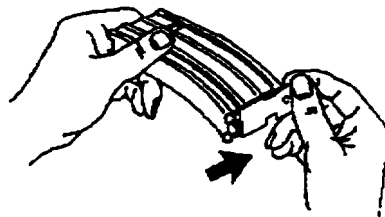

2. Remove base.

3. Jiggle spring and follower to remove.
4. Inspect feeder lips for damage. If damaged or bent, replace magazine.

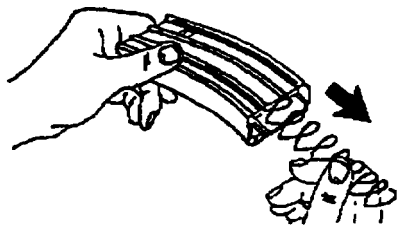

NOTE

Do not remove follower from spring.

MAGAZINE REASSEMBLY**NOTE**

If the spring comes loose from the follower, turn in the pieces. DO NOT try to fix it yourself.

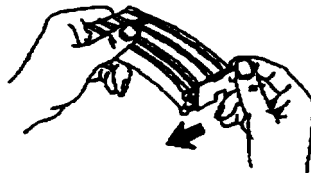
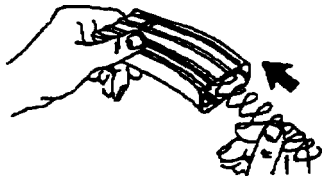
**NOTE**

Make sure printing on base is on the outside.

1. Clean and Lube. Wipe dirt from tube, spring, and follower; then lightly lube spring.
2. Insert follower and jiggle spring to install.

3. Slide the base under all four tabs until base catches.

END OF TASK

CHAPTER 4

M4 AND M5 ADAPTER RAILS

LOWER ADAPTER RAIL**WARNING**

To be considered SAFE before disassembly, cleaning, inspecting, transporting, or storing, the weapon must be cleared..

NOTE

The adapter rails, M5 for M16A4 rifle and M4 for M4 carbine series will replace the handguards. The operator is authorized to remove only the lower adapter rail for cleaning and lubrication, and the rail covers for cleaning, lubrication, or to attach accessories.

Orient the lower adapter rail by confirming that the arrow on its inner surface points towards the muzzle of the weapon.

INSTALLATION AND REMOVAL OF ADAPTER RAILS (Cont)

0018 00

LOWER ADAPTER RAIL (Cont)

1. Remove the lower adapter rail in the same manner as a standard lower handguard, by pulling back the handguard slip ring and removing the lower adapter rail section.
2. Reinstall the lower adapter rail in the same manner as a standard lower handguard by inserting its front edges into the forward handguard cap at the angle shown, and compressing the rear handguard slip ring while pivoting the lower adapter rail up and into its final position.
3. Release the rear handguard slip ring and confirm that it engages around the rear flange of the lower adapter rail assembly.

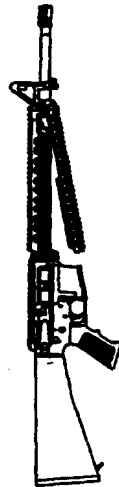

4. The recoil slots of each rail are sequentially numbered within the recoil slots themselves. The recoil slots of the top rail have a "T" prefix while those of the bottom rail have a "B" prefix. The recoil slots of the left rail have an "L" prefix, and the right rail have an "R" prefix. The numbers and prefixes are provided to assist in remounting an accessory in the same position if removed.

5. The installation of the rail has no effect on the attachment or operation of Multiple Integrated Laser Engagement System (MILES), the M7 and M9 bayonets, the M15A2 and M23 blank firing adapters, the top carry sling adapter, and standard sling. With the lower adapter rail removed, the M203 Grenade Launcher mounts under the barrel in its standard location using the M203 Quick Attach/Detach (QD) Mount, TM 9-1010-221-10.

ADAPTER RAIL COVERS

FULL LENGTH
 "11 RIB" (8.15")
 (4 EACH)



"9 RIB" (5.45")
 (2 EACH)



"6 RIB" (3.9")
 (1 EACH)



"3 RIB" (2.47")
 (2 EACH)



MEDIUM SHORT LENGTH
 "4 RIB" (2.85")
 (1 EACH)



M5 Covers

"11 RIB" (8.15")
 (4 EACH)



"8 RIB" (5.9")
 (2 EACH)



"4 RIB" (1 EACH) (2.85")



"2 RIB" (2 EACH) (1.85")



M4 covers

1. Several different lengths of rail covers are provided with the standard adapter rail systems. For ease of reference, they should be referred to by the number of ribs along their outer surfaces, i.e., "11 rib," "9 rib," "6 rib," "5 rib," and "4 rib." Rail covers for the rifle adapter rail are in illustration below.
2. Rail covers are quickly attached and detached from the adapter rail. A retaining clip at one end of each handguard section automatically engages a slot positioned at either end of the four rail sections. To slide a rail cover beyond a slot, or to remove it, slide it in the desired direction while applying thumb pressure to its retaining clip.

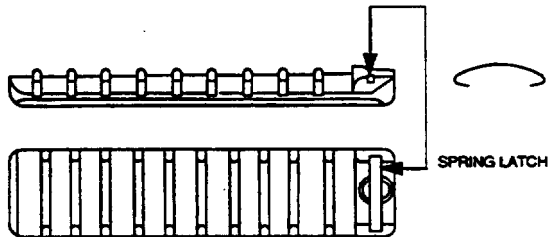

0018 00-5

ADAPTER RAIL COVERS (Cont)

3. To cover the side and bottom quadrants, install the rail covers from the muzzle end of the adapter rail. Longer rail cover on carbine should be oriented with the retaining clip toward muzzle (L-28, R-28, or B-28). Longer rail covers on rifle should be oriented with the retaining clip toward chamber (L-14, R-14, or B-14).
4. To cover the top rail, install the rail covers from the rear of the upper receiver assembly.

NOTE

The rail covers will lock only into the end slots of the rails.

5. As the retaining dip meets the slots at either end of the rail, it will engage the slats to secure itself. Shorter rail covers (used on rails partially occupied by accessories) should be, oriented with their retaining clip away from the accessories.

END OF TASK

CLEANING**NOTE**

All adapter rail covers are interchangeable between rifle and carbine.

The rail covers perform two primary functions:

- (a) They are configured to protect the operator's hands from direct skin contact with the metal parts of the adapter rails which get hot during extended firing.

- (b) They also protect the rail surfaces from excess wear and damage. For these reasons, rail covers should cover the unused sections of each rail at all times.

CLEANING (Cont)**NOTE**

Do not apply lubricant to the plastic surfaces of the rail covers.

1. Clean, inspect, and lubricate the rail surfaces and recoil slots of the adapter rails when the weapon is cleaned and/or when rail covers or accessories being installed or repositioned on the rails.
2. Use the general purpose brush the standard rifle/carbine cleaning kit to clean the adapter rails and rail covers.
3. If debris is observed inside the adapter rails, remove the lower adapter rail assembly. Thoroughly clean the inner surface of the thermal liner to maintain its heat reflective surface.
4. If the adapter rail is exposed to salt water or corrosive chemicals, thoroughly rinse the upper and lower assemblies in fresh water as soon as the tactical situation allows. Thoroughly dean, inspect, and lubricate as required, this includes the retaining clip in the rail covers.

5. In less adverse environments, lightly lubricate the upper and lower rail assemblies and the retaining clips in the rail covers during normal weapon cleaning.

END OF TASK

SIDE SLING ADAPTER

The standard side sling adapter, if installed, must be positioned so the sling swivel is to the right (right side of the weapon) in accordance with figure C-2 of Army TM 9-1010-221-23&P, and Navy SW 370-AE-MMI-010, Unit and Direct Support Maintenance Manual for M203 Grenade Launcher. The sling should be oriented so the integral stop, normally positioned towards the muzzle, is to the rear, this change in orientation allows the swivel to fold flat towards the muzzle so the side sling adapter does not interfere with the installation of the rail covers, the vertical pistol grip, or other accessories that require installation from the end of the rail.

The side sling adapter should be removed from the M4 carbine prior to mounting the M203 with quick attach/release bracket. There is potential interference between the M203 receiver and the side sling adapter.

ADAPTER RAIL ACCESSORY MOUNTING PROCEDURES

002 00

TOP SLING - The top sling adapter is the primary sling to be used with the M4 and M5 adapter rails.

INSTALLATION

RIFLE ONLY

1. Install top sling adapter strap (1) through sling swivel (2) and tie.

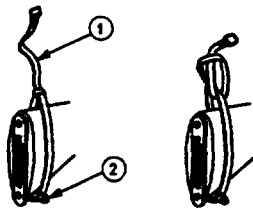

RIFLE

CARBINE ONLY

- Install top sling adapter strap (1) through sling opening (2) and tie.

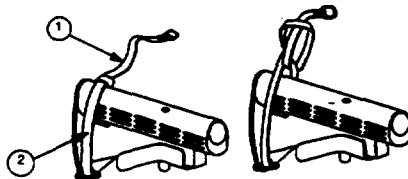

CARBINE

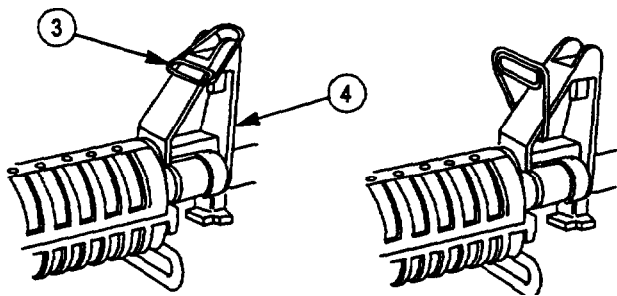

2. Use pliers to install clamp (3) on front sight base (4).

TOP SLING - INSTALLATION (Cont)

3. Attach sling (5) to top adapter strap (1) and to clamp (3).
4. Adjust sling (5).

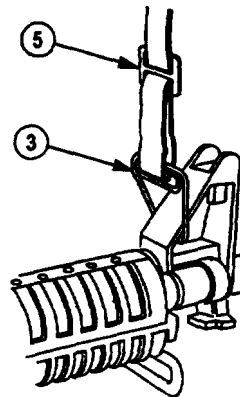
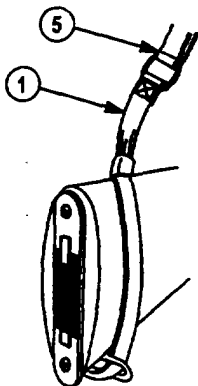

TOP SUNG - REMOVAL (Cont)

1. Remove sling (1) from clamp (2) and top sling adapter strap (3).

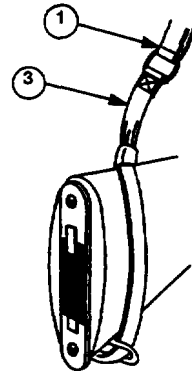
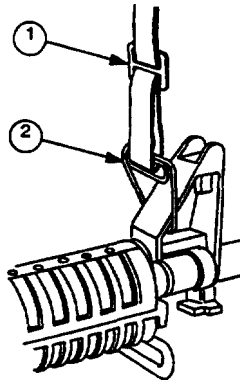

TOP SLING - REMOVAL (Cont)

2. Use pliers to remove clamp (2) from front sight base (4).

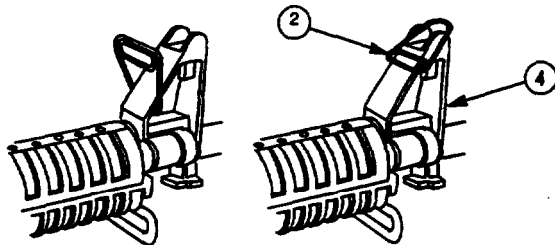

3. Untie top sling adapter strap (3) and remove from buttstock (5).
4. Install sling.

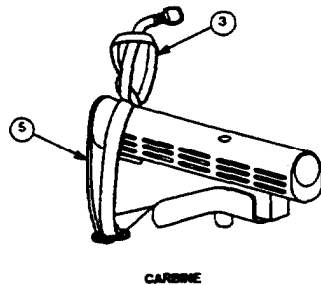
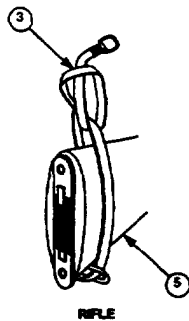

VERTICAL PISTOL GRIP

NOTE

The rail covers will lock only into the end slots of the rails.

1. Detach the rail cover section from the rail on which the pistol grip will be installed.

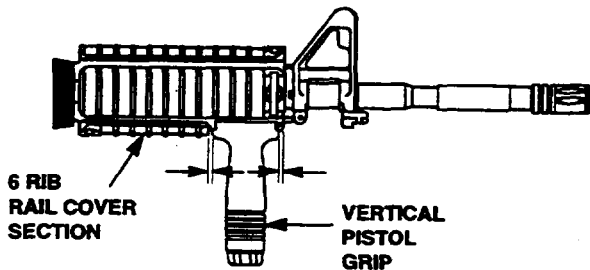

2. For the carbine, if the pistol grip will be installed at the muzzle end of the rail, first install a half length "6 rib" rail cover section so it latches into the end slot.

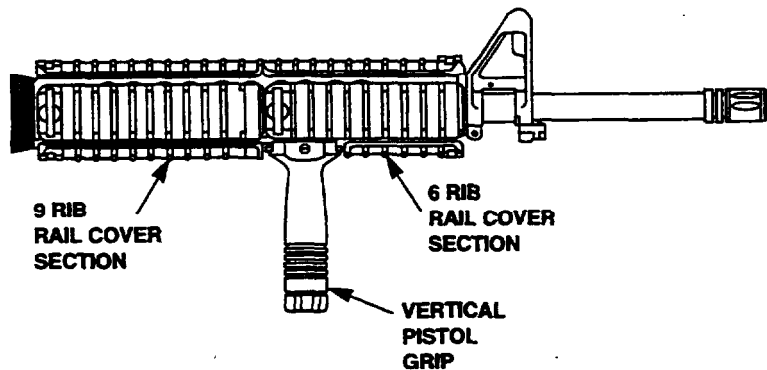

3. For the rifle, first install a "9 rib" rail cover, next the vertical pistol grip and then a "6 rib" rail cover. The pistol grip may be moved to the muzzle end, if desired.

ADAPTER RAIL ACCESSORY MOUNTING PROCEDURES

0020 00

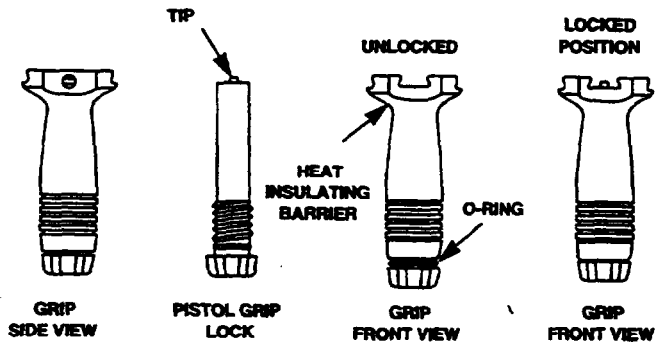

4. Unscrew the pistol grip lock to the point that the upper tip rests below the slotted surface of the base in the unlocked position.
5. Slide the pistol grip on the desired rail from the muzzle end.
6. If placed on the lower rail, the pistol grip is aligned so it covers the first five slots and the pistol grip lock is aligned into the third slot from the end

0020 00-10

NOTE

Assure the top of the pistol grip lock is aligned with a rail slot or the top may be damaged. In addition, the pistol grip may come loose if the top is not aligned properly into a slot.

7. With the tip of the pistol grip lock centered into the desired recoil slot, while observing through the holes in the side of the pistol grip, screw the lock all the way into the grip to the locked position until hand tight. There is a coin slot in the base of the grip lock to aid in later disassembly.
8. If the pistol grip is installed at other locations. experiment with rail cover sections of different lengths to protect the rail surface and the shooter's hand from contact with the metal parts of the rail.

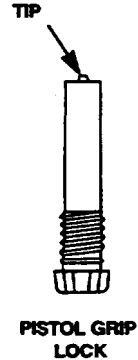

CLEANING & INSPECTION OF THE VERTICAL PISTOL GRIP

1. Clean, inspect and lubricate when the pistol grip is installed or repositioned on the tail. At a minimum, clean and inspect weekly. More frequent cleaning may be necessary by operational conditions.
2. For cleaning and inspection, remove the pistol grip from the rail. Then unscrew and remove the lock from the base of the pistol grip. Clean the lock and base (including the internal threads) as well as the rail surface and recoil slots exposed by the removal of the pistol grip and rail cover.

NOTE

Care should be taken while stoning on the rails to not alter the dimensions of the slots or rail edges.

3. Burrs which interfere with attachment or detachment may be removed by an armorer using a stone.

4. Lightly lubricate the rail surfaces but not the pistol grip itself. The shaft and threads of the pistol grip lock are self lubricating polymer and should not require lubrication.

END OF TASK

CHAPTER 5

AMMUNITION

AMMUNITION: 5.56MM**WARNING****DO NOT FIRE:**

- Seriously corroded ammunition.
- Dented cartridges
- Cartridges with loose bullets.
- Cartridges exposed to extreme heat (135°) until they have Cooled.
- Cartridges with the bullet pushed in (short rounds).

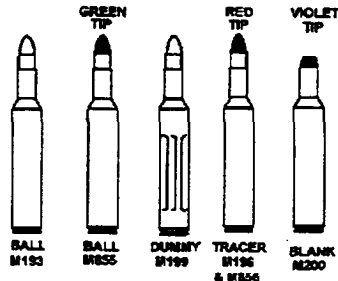

Turn in to range NCO.

Use only authorized ammunition. Keep ammunition dry and clean.

END OF TASK

APPENDIX A
REFERENCE PUBLICATIONS

DEPARTMENT OF THE ARMY PAMPLETS AND FORMS

- DA PAM 738-750 . . . The Army Maintenance Management System
(TAMMS)
DA Form 2028 Recommended Changes to Publications and Blank Forms
SF 364 Report of Discrepancy (ROD)
SF368 Product Quality Deficiency Report

FIELD MANUALS

- FM 23-9 M16A1 Rifle and Rifle Marksmanship
FM 3-3 Nuclear, Biological and Chemical Contamination Avoidance
FM 3-4 Nuclear, Biological and Chemical Protection
FM 3-5 Nuclear, Biological and Chemical Decontamination
FM 3-100 Nuclear, Biological and Chemical Defense, Chemical
Warfare, Smoke, and Flame Operations
FM 21-11 First Aid for Soldiers

TECHNICAL MANUALS

- SW 370-AE-MMI-010 Unit and Direct Support Maintenance Manual for
M203 Grenade Launcher
- TM 3-4230-216-10 Operator's Manual for Decontamination Kit, Skin:
M266A1 and Training Aid, Skin Decontaminating:
M58A1
- TM 9-1005-319-23&P Unit and Direct Support Maintenance Manual for,
M16A2/M16A3/M16A4 Rifle and M4/M4A1 Carbine
- TM 9-1010-221-10 Operator's Manual for M203 Grenade Launcher
- TM 9-1010-221-23&P Unit and Direct Support Maintenance Manual for
M203 Grenade Launcher
- TM 4700-15/1 Record Reporting Procedures

RELATED PUBLICATIONS

DOD 4160.21-M-1Defense Demilitarization Manual

SI-1300-15/2B Procedure for Requesting Disposition for Class V (W)
Materiel

END OF TASK

APPENDIX B

COMPONENTS OF END ITEM,

BASIC ISSUE ITEMS LISTS,

ADDITIONAL AUTHORIZED LISTS

AND

EXPENDABLE/DURABLE SUPPLIES AND MATERIALS LISTS

SCOPE

These work packages lists Components of End Item (COEI) and Basic Issue Items (BII) for the M16 series rifles and M4 series carbines to help you inventory items required for safe and efficient operation of the equipment.

GENERAL

The COEI and BII Lists are divided into the following lists:

COEI. This list is for informational purposes only and is not authority to requisition replacements. These items are part of the M16 series rifles and M4 series carbines. As part of the end item, these items must be with the end item whenever it is issued or transferred between property accounts. Items of COEI are removed and separately packaged for transportation or shipment only when necessary.

GENERAL (Cont)

BII. These essential items required to place the M16 series rifles and M4 series carbines in operation, operate it, and to do emergency repairs. Although shipped separately packaged, BII must be with the M16 series rifles and M4 series carbines during operation and whenever it is transferred between property accounts. Listing these items is your authority to request/requisition them for replacement based on authorization of the end item by the TOE/MTOE. Illustrations are furnished to help you find and identify the items.

EXPLANATION OF COLUMNS IN THE COEI LIST AND BII LIST

Column (1) - Illus Number. Gives you the number of the item illustrated.

Column (2) - National Stock Number (NSN). Identifies the stock number of the item to be used for requisitioning purposes.

Column (3) - Description, CAGEC, and Part Number. Identifies the Federal name (in all capital letters) followed by a minimum description when needed. The stowage location of COEI and BII is also included in the column. The last line below the description is the CAGEC (Commercial and Government Entity Code) (in parentheses) and the part number.

Column (4) - Usable On Code. When applicable, gives you a code if the item you need is not the same for different models of equipment.

Code

Used On

Column (5) - Unit of Measure (U/M). Indicates the physical measurement or count of the item as issued per the National Stock Number shown in column (2).

Column (6) - Qty Rqrd. Indicates the quantity required.

COMPONENTS OF END ITEM**0023 00**

(1) ILLUS NO.	(2) NATIONAL STOCK NUMBER	(3) DESCRIPTION, CAGEC, AND PART NUMBER	(5) UOC	(5) U/M	(6) QTY RQR
	1005-00-921-5004	MAGAZINE, CARTRIDGE: 30 Round (19204) 6448670		EA	1
	1005-01-2164570	SLING, SMALL ARMS (19204) 12624561		EA	1
	1005-01-368-9852	SLING, SMALL ARMS, CARBINE (19200) 12011996		EA	1

END OF TASK

0023 00-4

BASIC ISSUE ITEMS**0024 00**

(1) ILLUS NO.	(2) NATIONAL STOCK NUMBER	(3) DESCRIPTION, CAGEC, AND PARTNUMBER	(4) UOC	(5) U/M	(6) QTY RQR
		TM 9-1005-319-10		E A	1

END OF TASK

SCOPE

This work package lists additional items you are authorized for the support of the M16 series rifles and M4 series carbines.

GENERAL

This list identifies items that do not have to accompany the M16 series rifles and M4 series carbines and that do not have to be turned in with it. These items are all authorized to you by CTA, MTOE, TDA. or JTA.

EXPLANATION OF COLUMNS IN AAL

Column (1) - National Stock Number (NSN). Identifies the stock number of the item to be used for requisitioning purposes.

EXPLANATION OF COLUMNS IN AAL (Cont)

Column (2) - Description, Commercial and Government Entity Code (CAGE), and Part Number (P/N). Identifies the Federal item name (in all capital letters) followed by a minimum description when needed. The last line below the description is the CAGEC (in parentheses) and the part number.

Column (3) - Usable On Code. When applicable, gives you a code if the item you need is not the same for different models of equipment

Code Used On

Column (4) - Unit of Measure (U/M). Indicates the physical measurement or count of the item as issued per the National Stock Number shown in column (1).

Column (5) - Qty Recm. Indicates the quantity recommended.

(1) NATIONAL STOCK NUMBER	(2) DESCRIPTION, CAGEC, AND PART NUMBER	(3)	(4) U/M	(5) QTY RECM
1005-00-193-3306	BAG, PROTECTIVE: for 30 round magazine (500 per box) required 1 per magazine (19204) 8448464		BX	1
1005-00-118-6192	BLANK FIRING ATTACHMENT M15A2: (For Training Only) (Rifle only) (Red) (19204) 12002900		EA	1
1005-01-361-8308	BLANK FIRING ATTACHMENT M23: (For Training Only) (Carbine Only) (Yellow) (19200) 12597837		EA	1
1005-00-242-5687	BOTTLE ASSEMBLY CYLINDRICAL (19204) 8448444		E A	1

ADDITIONAL AUTHORIZED LIST (Cont)**0025 00**

(1) NATIONAL STOCK NUMBER	(2) DESCRIPTION, CAGEC, AND PART NUMBER	(3) UOC	(4) U/M	(5) QTY RECM
1005-00-903-1296	BRUSH, CLEANING, SMALL ARMS: bore (19204) 11686340		EA	1
1005-00-999-1435	BRUSH, CLEANING, SMALL ARMS: chamber (19204) 8432358		EA	1
1005-00-494-6602	BRUSH, CLEANING. SMALL ARMS: tooth (19204) 8445067		EA	1
5340-00-880-7666	CAP, PROTECTIVE, DUST (19204) 8445067		EA	1

0025 00-4

(1) NATIONAL STOCK NUMBER	(2) DESCRIPTION, CAGEC, AND PART NUMBER	(3) UOC	(4) U/M	(5) QTY RECM
1005-00-403-5804	CASE, SMALL ARMS: for rifles with buttstock storage (19204) 8448751		EA	1
8465-00-781-9564	CASE, Maintenance equipment for weapons without buttstock stowage (Carbine only) (81349) MIL-C-43737		EA	1
1005-01-113-0321	HANDLE SECTION, CLEANING ROD. SMALL ARMS (19204) 8436776		EA	1
1005-00-921-5004	MAGAZINE, CARTRIDGE: 30 round (19204) 84483670		EA	6
1005-00-233-9031	PLATE, LOCKING: for riot control use, prevents selector from auto- matic fire (refer to unit maintenance for installation and instructions on use) (19204) 844676		E A	1

ADDITIONAL AUTHORIZED LIST (Cont)**0025 00**

(1) NATIONAL STOCK NUMBER	(2) DESCRIPTION, CAGEC, AND PART NUMBER	(3) UOC	(4) U/M	(5) QTY RECM
1005-00-050-6357	ROD SECTION, CLEANING ROD, SMALL ARMS (19204) 8436775		EA	3
1005-00-937-2250	SWAB HOLDER SECTION, CLEANING ROD, SMALL ARMS (19204) 11686327		EA	1
1005-00-406-1570	TOP SUNG ADAPTER KIT (19204) 8448471		EA	1

0025 00-6

(1) NATIONAL STOCK NUMBER	(2) DESCRIPTION, CAGEC, AND PART NUMBER	(3) UOC	(4) U/M	(5) QTY RECM
1005-00-017-9701	MTOE AUTHORIZED ITEMS BAYONET - KNIFE M7 W/SCABBARD (19204) 8427025		EA	1
1005-01-227-1739	BAYONET - SYSTEM, M9 MULTIPURPOSE 12011861 M9 P/N		EA	1

END OF TASK

0025 00-7/8 blank

INTRODUCTION**SCOPE**

This work package lists expendable and durable items that you will need to operate and maintain the M16 series rifles and M4 series carbines. This list is for information only and is not authority to requisition the listed items. These items are authorized to you by CTA 50-970, Expendable/Durable Items (Except Medical, Class V Repair Parts, and Heraldic items), or CTA 8-100, Army Medical Department Expendable/Durable Items.

EXPLANATION OF COLUMNS IN THE EXPENDABLE/DURABLE ITEMS LIST

Column (1) - Item Number. This number is assigned to the entry in the list and is referenced in the narrative instructions to identify the item (e.g., Use wiping rag, (item 5, WP 0034 00).)

**EXPLANATION OF COLUMNS IN THE EXPENDABLE/DURABLE ITEMS LIST
(Cont)**

Column (2) - Level. This column identifies the lowest level of maintenance that requires the listed item.

C - operator/crew

Column (3) - National Stock Number (NSN). This is the NSN assigned to the item which you can use to requisition it.

Column (4) - Item Name, Description, Commercial and Government Entity Code (CAGEC), and Part Number (P/N). This column provides the other information you need to identify the item.

Column (5) - Unit of Measure (U/M). This code shows the physical measurement or count of an item, such as gallon, dozen, gross, etc.

(1) ITEM NUMBER	(2) LEVEL	(3) NATIONAL STOCK NUMBER	(4) DESCRIPTION, CAGEC, AND PART NUMBER	(5) U/M
1	C	9150-01-102-1473	CLEANER, LUBRICANT AND PRESERVATIVE (CLP): 1/2 oz bottle (81349) MIL-L-63460	OZ
2	C	9920-00-292-9946	CLEANER, TOBACCO PIPE: cotton tuft, wire core (32 per pack) (89666) DILLS PIPE CLEANER	E A
3	C	6850-00-224-6656	CLEANING COMPOUND, RIFLE BORE (RBC): 2oz bottle (81349) MIL-C-372	O Z
4	C	1005-00-809-2190	COVER. PROTECTIVE, RIFLE for M16 Series Rifles (25 per box) (19204) 8448213	EA

0026 00-3

**EXPENDABLE/DURABLE SUPPLES AND
WATERIALS LIST (Cont)**

0026 00

(1) ITEM NUMBER	(4) LEVEL	(3) NATIONAL STOCK NUMBER	(4) DESCRIPTION, CAGEC, AND PART NUMBER	(5) U/M
5	O	6850-00-281-1985	DRY CLEANING SOLVENT (3.79L) 1 Gallon can (58536)	GL
6	C	9150-00-292-9689	LUBRICATING OIL, ARCTIC WEAPONS (LAW) (1 quart can) (81349) MIL-L-14107	EA
7	C	9150-00-935-6597	LUBRICATING OIL, WEAPONS (LSA): Semifluid, 2 oz.. (59.15 ml) Plastic btl (81349) MIL-L-46000	OZ

0026 00-4

(1) ITEM NUMBER	(2) LEVEL	(3) NATIONAL STOCK NUMBER	(4) DESCRIPTION, CAGEC, AND PART NUMBER	(5) U/M
8	C	9150-00-889-3522	LUBRICATING OIL WEAPONS (LSA): Semifluid, 4 oz.. (118.30 ml) Plastic btl (81349) MIL-L-46000	O Z
9	C	7920-00-205-1711	RAG, WIPING: 50 lb bdl (58538) A-A-531	L B
10	C	1005-00-912-4248	SWAB, SMALL ARMS CLEANING: cotton, 1 pkg (1000 per package) (19204) 11686408	E A

END OF TASK

0026 00-5/6 blank

By Order of the Secretary of the Army:

Official:

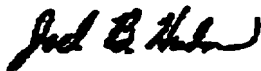
A handwritten signature in black ink, appearing to read "Joel B. Hudson". The signature is written in a cursive style with a large initial "J" and a long, sweeping underline.

JOEL B. HUDSON
Administrative Assistant to the
Secretary of the Army
05129

GARY G. BISHOP
Colonel, united states Army
Chief of Staff

