

ATP 4-02.4

Medical Platoon

MAY 2021

DISTRIBUTION RESTRICTION: Approved for public release; distribution is unlimited.

Headquarters, Department of the Army

Foreword

As the U.S. Army transitions from counterinsurgency operations to Large-Scale Combat Operations (LSCO) in a multi-domain battlefield, operational medical forces must optimize efforts at echelon for maximum effectiveness. LSCO demands a flexible and agile force that must adapt in order to win in unified land operations.

The medical platoon must train and operate to support combat operations. Just as the Army seeks dominance in volatile, complex, and ambiguous environments, Army Medicine must redefine how the Army Health System evolves to support emerging doctrine.

Army Technique Publication (ATP) 4-02.4, “The Medical Platoon”, is one of the four cornerstone Army Health System publications updated to provide a doctrinal guide of capabilities at each echelon of care. ATP 4-02.4 is a doctrinal application of the medical platoon’s capability and capacity from casualty response (self-aid/buddy aid) to care at the medical platoon level (Role 1). This publication outlines training considerations to help strengthen platoon operations in battalion-level Army Health System support. This publication serves as the catalyst for leaders to perform now, develop competence in their capabilities, and shape future operations for medical platoons.

TO CONSERVE FIGHTING STRENGTH!



DENNIS P. LEMASTER
MAJOR GENERAL, UNITED STATES
ARMY
COMMANDING

This publication is available at the Army Publishing Directorate site (<https://armypubs.army.mil>), and the Central Army Registry site (<https://atiam.train.army.mil/catalog/dashboard>).

Medical Platoon

Contents

	Page
PREFACE	xiii
INTRODUCTION	xv
Chapter 1 ROLE OF THE MEDICAL PLATOON	1-1
Section I – Role 1 Army Health System Overview	1-1
Medical Platoons in Decisive Action.....	1-1
Variables of the Operational Environment.....	1-4
Warfighting and Medical Functions	1-4
Army Health System Principles	1-8
Roles of Medical Care	1-11
Tactical Combat Casualty Care.....	1-13
Casualty Evacuation.....	1-14
Medical Evacuation	1-15
Section II – Threats	1-15
Regular and Irregular Threat Description	1-16
Health Threat	1-16
Threat Impact on Medical Units.....	1-19
Section III – Medical Platoon Capabilities and Key Personnel	1-19
Common Medical Platoon Capabilities.....	1-19
Duties and Responsibilities by Title	1-20
Section IV – Medical Platoon Task Organization	1-31
Combined Arms Battalion (Infantry)	1-31
Combined Arms Battalion (Armored).....	1-32
Infantry Battalion Medical Platoon	1-33
Airborne Infantry Battalion Medical Platoon	1-34
Stryker Battalion Medical Platoon.....	1-35
Section V – Employment of the Medical Platoon	1-36
Medical Platoon Headquarters	1-36
Medical Treatment Squad	1-37
Ambulance Squad	1-47

	Ambulance Team	1-48
	Combat Medic Section	1-51
	Section VI – Brigade and Echelon Above Brigade Medical Assets in Support of the Medical Platoon	1-59
	Brigade Surgeon	1-59
	Brigade Surgeon's Section	1-60
	Additional Medical Assets Operating in the Brigade Area of Operations	1-61
Chapter 2	COMMAND AND CONTROL.....	2-1
	Section I – Platoon Mission Command	2-1
	Mission Command Principles	2-1
	Importance of Commander's Intent	2-3
	Section II – Planning Considerations	2-3
	Planning, Execution, and Assessment	2-4
	Parallel and Collaborative Planning	2-4
	Section III – Troop Leading Procedures.....	2-6
	Step 1 – Receive the Mission	2-8
	Step 2 – Issue a Warning Order	2-14
	Step 3 – Make a Tentative Plan	2-16
	Step 4 – Initiate Movement	2-28
	Step 5 – Conduct Reconnaissance	2-28
	Step 6 – Complete the Plan	2-29
	Step 7 – Issue the Order	2-29
	Step 8 – Supervise and Refine.....	2-32
	Section IV – Military Decision-making Process.....	2-35
	Characteristics of Military Decision-making Process	2-35
	Steps of Military Decision-making Process	2-39
	Section V – Risk Management	2-49
	Risk Management Process	2-49
	Risk Mitigation and Control	2-50
	Section VI – Rehearsals.....	2-50
	Rehearsal Purposes.....	2-51
	Rehearsal Types	2-51
	Methods of Rehearsals	2-53
	Section VII – Precombat Checks and Inspections	2-55
	Precombat Checks.....	2-56
	Precombat Inspections.....	2-56
	Section VIII – After Action Reviews	2-58
	Introduction to After Action Reviews and Reports	2-58
	Formal and Informal After Action Reviews	2-58
	Benefits of After Action Reviews	2-60
	Conducting After Action Reviews	2-60

Executing After Action Reviews	2-64
The After Action Report.....	2-66
Section IX – Communications	2-68
Medical Platoon Radio Nets	2-68
Platoon Nets.....	2-69
Command Nets	2-69
Administrative and Logistics Net	2-69
Retransmission	2-69
Medical Primary, Alternate, Contingency, and Emergency Plan	2-70
Medical Communication for Combat Casualty Care.....	2-70
Chapter 3 ARMY HEALTH SYSTEM SUPPORT TO OPERATIONS.....	3-1
Section I – Army Health System Support for the Offense	3-2
Army Health System Planning in the Offense	3-2
Army Health System Support to Movement to Contact	3-6
Army Health System Support of the Attack	3-8
Army Health System Support of the Envelopment	3-8
Army Health System Support of the Turning Movement	3-10
Army Health System Support to Penetration	3-10
Army Health System Support of Exploitation and Pursuit	3-13
Army Health System Support of the Reconnaissance in Force	3-14
Section II – Army Health System Support for the Defense.....	3-14
Army Health System Planning in the Defense.....	3-15
Army Health System Support of the Area Defense	3-17
Army Health System Support of the Mobile Defense	3-20
Army Health System Support to Retrograde Operations.....	3-20
Army Health System Support of Delaying Operations.....	3-24
Army Health System Support of Withdrawal	3-25
Army Health System Support of the Retirement.....	3-27
Section III – Army Health System Support in Stability and Defense Support of Civil Authorities Operations	3-28
Army Health System Support to Stability Operations	3-28
Army Health System Support to Defense Support of Civil Authorities Operations.....	3-29
Section IV – Army Health System Support to Night Operations	3-30
Conducting Night Operations	3-31
Army Health System Support Considerations	3-32
Infrared Devices	3-32
Night Vision Devices	3-32
Techniques for Using Chemical Lights for Marking and Signaling	3-33
Section V – Army Health System Support in Mountain Warfare and Cold Weather Operations	3-34
Army Health System Planning for Mountainous and Cold Weather Environments	3-34

	Army Health System Cold Weather Planning Factors.....	3-41
	Cold Weather Environment Medical Considerations.....	3-44
	Section VI – Army Health System Support to Jungle Operations.....	3-45
	Medical Considerations.....	3-46
	Evacuation.....	3-47
	Medical Supplies (Class VIII Including Medical Repair Parts).....	3-48
	Section VII – Army Health System Support in Desert Operations.....	3-48
	Medical Considerations.....	3-49
	Command and Control.....	3-51
	Evacuation.....	3-51
	Operational Public Health and Sanitation.....	3-52
	Section VIII – Army Health System Support to Urban Operations.....	3-53
	Health Service Support Considerations.....	3-54
	Other Medical Urban Considerations.....	3-54
	Section IX – Army Health System Support to Subterranean Operations.....	3-55
	Effects of Operating in Confined Spaces Combined With Little or No Light.....	3-55
	Disease.....	3-55
	Trauma.....	3-56
	Behavioral Health Issues.....	3-56
	Emotional, Moral, and Spiritual Health Issues.....	3-56
	Blast Injuries.....	3-57
	Section X – Army Health System Support to Wet Gap Crossing Operations.....	3-58
	Considerations Influencing Army Health System Support.....	3-59
	Preliminary Phase.....	3-59
	Phase I.....	3-59
	Phase II.....	3-60
	Phase III.....	3-60
	Section XI – Army Health System Support to Air Assault Operations.....	3-60
	The Air Assault Division.....	3-60
	Air Assault Medical and Casualty Evacuation.....	3-61
	Section XII – Army Health System Support to Airborne Operations.....	3-64
	The Airborne Division.....	3-64
	Deployment and Employment of the Airborne Medical Platoon.....	3-65
Chapter 4	SUSTAINMENT.....	4-1
	Section I – Basics of Sustainment.....	4-1
	Leader Responsibilities.....	4-2
	Sustainment Functions.....	4-5
	Classes of Supply.....	4-6

	Section II – Sustainment Planning.....	4-6
	Sustainment Planning Factors	4-7
	Forecasting Logistics.....	4-9
	Basic and Combat Loads	4-20
	Load Planning Considerations	4-20
	Sustainment Overlay.....	4-21
	Sustainment Reporting.....	4-25
	Section III – Medical Platoon Supply Operations	4-25
	Resupply Methods.....	4-25
	Resupply Procedures	4-27
	Resupply Site Selection	4-27
	Resupply Techniques.....	4-28
	Medical Platoon Responsibilities to Medical Equipment Set Management	4-35
	Section IV – Maintenance	4-37
	Maintenance Categories	4-38
	Vehicle Recovery	4-45
	Section V – Disposition of Human Remains	4-47
	Battalion Aid Station Responsibilities	4-47
	Battalion Aid Station Relocation	4-47
	Section VI – Army Health System Support to Detainees	4-48
	Principles of Detainee Health Care	4-48
	Categories of Detainee Health Care.....	4-49
	Responsibilities of Health Care Personnel	4-50
Chapter 5	CHEMICAL, BIOLOGICAL, RADIOLOGICAL, AND NUCLEAR OPERATIONS	5-1
	Section I – Mission-Oriented Protective Posture	5-1
	Mission-Oriented Protective Posture	5-2
	Protective Equipment	5-2
	Section II – Actions During and After an Attack.....	5-4
	Chemical Defense	5-5
	Biological Defense.....	5-5
	Nuclear Defense	5-5
	Marking Contaminated Areas.....	5-7
	Section III – Unit Decontamination	5-9
	Immediate Decontamination.....	5-9
	Operational Decontamination.....	5-10
	Thorough Decontamination	5-10
	Section IV – Role 1 Health Service Support in a Chemical, Biological, Radiological, and Nuclear Environment.....	5-12
	Operation of a Role 1 Battalion Aid Station in a Chemical Environment.....	5-13

Operation of a Role 1 Battalion Aid Station in a Biological Environment.....	5-15
Operation of a Role 1 Battalion Aid Station in a Nuclear Environment.....	5-17
Medical Evacuation in a Chemical, Biological, Radiological, and Nuclear Environment.....	5-19
Section V – Role 1 Battalion Aid Station Decontamination.....	5-21
Interior.....	5-22
Exterior.....	5-23
Section VI – Patient Decontamination.....	5-24
Chemical, Biological, Radiological, and Nuclear Mass Casualty.....	5-24
Medical Support in Troop/Personnel Decontamination Operations.....	5-27
Patient Decontamination Principles.....	5-28
Zones of Contamination.....	5-30
Collective Protective Shelter System.....	5-38
Establishing a Patient Decontamination Site.....	5-43
Core Components of the Patient Decontamination Site and Patient Flow.....	5-55
Patient Decontamination Operational Considerations.....	5-64
Procedures for Closing Down a Patient Decontamination Site.....	5-70
Additional Proficiency Skills For Medical Platoon Personnel.....	5-71
Section VII – Unmasking Procedures.....	5-73
Unmasking With a Chemical Detector Kit.....	5-73
Unmasking Without a Chemical Detector Kit.....	5-74
All-Clear Signal.....	5-74
Appendix A ANALOG REPORTS.....	A-1
Appendix B MEDICAL BATTLE DRILLS.....	B-1
Appendix C PATIENT EVACUATION.....	C-1
Appendix D FORCE HEALTH PROTECTION AND MEDICAL READINESS.....	D-1
Appendix E MEDICAL TRAINING CONSIDERATIONS.....	E-1
Appendix F BATTALION-LEVEL SYMBOLOGY.....	F-1
Appendix G LAW OF LAND WARFARE AND MEDICAL ETHICS.....	G-1
Appendix H TACTICAL STANDARD OPERATING PROCEDURES.....	H-1
GLOSSARY.....	Glossary-1
REFERENCES.....	References-1
INDEX.....	Index-1

Figures

Figure 1-1. Medical function to warfighting function linkage.....	1-5
---	-----

Figure 1-2. Army Health System principles 1-9

Figure 1-3. Army Health System roles of care 1-11

Figure 1-4. Combined arms battalion (infantry) medical platoon 1-32

Figure 1-5. Combined arms battalion (armored) medical platoon..... 1-33

Figure 1-6. Infantry battalion medical platoon 1-34

Figure 1-7. Airborne infantry battalion medical platoon..... 1-35

Figure 1-8. Stryker battalion medical platoon..... 1-36

Figure 1-9. Example, battalion aid station configuration, tailgate medical support..... 1-40

Figure 1-10. Example, battalion aid station configuration, hasty..... 1-41

Figure 1-11. Example, battalion aid station configuration, short-term 1-42

Figure 1-12. Example, battalion aid station configuration, long-term 1-43

Figure 1-13. Extended medical support task organization 1-44

Figure 1-14. Extended medical support techniques 1-46

Figure 1-15. Example, casualty collection point, open area or field... 1-55

Figure 1-16. Example, notional casualty collection point at a breach 1-56

Figure 1-17. Example, casualty collection point in a building..... 1-58

Figure 1-18. Brigade support medical company, armored brigade combat team 1-63

Figure 1-19. Brigade support medical company, infantry and airborne brigade combat team 1-64

Figure 1-20. Brigade support medical company, Stryker brigade combat team 1-64

Figure 1-21. Example, brigade support medical company with attached forward resuscitative and surgical detachment layout..... 1-65

Figure 1-22. Complete forward resuscitative and surgical detachment 1-66

Figure 1-23. Split forward resuscitative and surgical detachment..... 1-67

Figure 1-24. Ground ambulance section 1-68

Figure 1-25. Preventive medicine team..... 1-70

Figure 1-26. Veterinary service support team 1-71

Figure 1-27. Combat and operation stress control forward support section..... 1-72

Figure 1-28. Forward support medical evacuation platoon..... 1-73

Figure 1-29. Forward distribution and contact repair teams 1-74

Figure 2-1. Parallel planning 2-5

Figure 2-2. Sample planning timeline 2-7

Figure 2-3. Enemy course of action 2-19

Figure 2-4. Line of sight analysis 2-22

Figure 2-5. Modified combined obstacle overlay, example..... 2-24

Figure 2-6. Operation order checklist..... 2-32

Figure 2-7. The seven steps of military decision-making process 2-38

Figure 2-8. Rapid decision-making and synchronization process 2-39

Figure 2-9. Step 1 – Receipt of mission..... 2-39

Figure 2-10. Step 2 – Mission analysis 2-41

Figure 2-11. Step 3 – Course of action development 2-44

Figure 2-12. Sample brigade course of action sketch 2-45

Figure 2-13. Step 4 – Course of action analysis and war-gaming 2-47

Figure 2-14. Step 5 – Course of action comparison 2-47

Figure 2-15. Step 6 – Course of action approval 2-48

Figure 2-16. Step 7 – Orders production, dissemination, and transition 2-48

Figure 2-17. Risk management process 2-49

Figure 2-18. Methods of rehearsals 2-53

Figure 2-19. Example of medical platoon nets..... 2-68

Figure 4-1. Medical logistics distribution overlay 4-14

Figure 4-2. Example, brigade medical supply warehouse layout 4-15

Figure 4-3. Sustainment overlay 4-22

Figure 4-4. Medical logistics concept of sustainment 4-24

Figure 4-5. Tailgate resupply technique..... 4-29

Figure 4-6. Service station resupply technique..... 4-31

Figure 4-7. Combination of tailgate and service station resupply 4-32

Figure 4-8. In-position resupply method 4-33

Figure 4-9. Detainee handling flow chart 4-52

Figure 5-1. Patient decontamination site layout..... 5-31

Figure 5-2. Battalion aid station, chemical-biological protective shelter system..... 5-39

Figure 5-3. Battalion aid station using the chemical-biological protective shelter.....	5-42
Figure 5-4. Patient decontamination site component areas.....	5-56
Figure C-1. Landing point sizes.....	C-8
Figure H-1. Format for changes and corrections	H-8

Tables

Table 1-1. Primary tasks and purposes of the Role 1 medical platoon, medical treatment (organic and area support) function.....	1-3
Table 1-2. Primary tasks and purposes of the Role 1 medical platoon, medical evacuation function.....	1-3
Table 1-3. Health threat.....	1-18
Table 1-4. Brigade surgeon section	1-60
Table 2-1. Example, hasty synch matrix	2-16
Table 2-2. Avenue of approach to mobility corridor comparison examples.....	2-21
Table 2-3. Example observation and fields of fire, avenues of approach, key terrain, obstacles, and cover and concealment matrix.....	2-23
Table 2-4. Example effects of weather matrix.....	2-25
Table 2-5. Examples of commander's planning guidance by warfighting function	2-42
Table 2.6. Precombat checks and precombat inspection checklist example.....	2-57
Table 2-7. After action report format	2-66
Table 2-8. Primary, alternate, contingency, and emergency examples.....	2-70
Table 3-1. Offensive tasks, purposes, and key medical considerations	3-4
Table 3-2. Defensive tasks, purposes, and key medical considerations	3-16
Table 3-3. Stability tasks, purposes, and key medical considerations	3-28
Table 3-4. Defense support of civil authorities tasks, purposes, and key medical considerations.....	3-30
Table 3-5. Medical considerations for blast injuries	3-58
Table 4-1. Sustainment functions	4-5

Table 4-2. Classes of supply	4-6
Table 4-3. Requirements for universal unit level gallons per person per day.....	4-10
Table 4-4. Daily environmental water consumption chart in gallons per person.....	4-11
Table 4-5. Medical platoon vehicle burn rates	4-11
Table 4-6. Medical platoon vehicle burn rate equation	4-12
Table 5-1. Mission-oriented protective posture levels	5-3
Table 5-2. Chemical, biological, radiological, and nuclear markers	5-7
Table 5-3. Decontamination levels.....	5-11
Table 5-4. Patient decontamination levels and responsible unit.....	5-28
Table 5-5. Work/rest cycles and water consumption	5-36
Table 5-6. Permissible heat exposure threshold limit value	5-36
Table 5-7. Suggested minimal staffing for one work cycle	5-44
Table 5-8. Equipment and supplies needed for a decontamination lane	5-50
Table 5-9. Equipment and supplies required for the contamination check area at a patient decontamination site with minimal equipment	5-52
Table 5-10. Equipment and supplies required for the hot line at a patient decontamination site with minimal equipment.....	5-52
Table 5-11. Decontamination methods based on ambient temperature	5-70
Table 5-12. Equipment and supplies required for the closure/disestablishment of a patient decontamination site	5-71
Table 5-13. Additional proficiency skills for medical platoon personnel	5-72
Table A-1. Spot report.....	A-1
Table A-2. Situation report	A-2
Table A-3. Sensitive items report.....	A-4
Table A-4. Logistics resupply request.....	A-4
Table A-5. Logistics situation report.....	A-5
Table A-6. Maintenance support request.....	A-6
Table A-7. Slant report.....	A-7
Table A-8. Medical evacuation request.....	A-8
Table A-9. Medical location report	A-9

Table A-10. Medical situation report.....	A-10
Table A-11. Medical spot report	A-10
Table A-12. Personnel status report.....	A-11
Table A-13. Chemical, biological, radiological, and nuclear- 1—Observer’s initial report	A-12
Table A-14. Chemical, biological, radiological, and nuclear- 3—Immediate warning of expected contamination.....	A-13
Table A-15. Chemical, biological, radiological, and nuclear - 5—Report of areas of contamination	A-13
Table A-16. Decontamination request.....	A-14
Table B-1. Establish the battalion aid station	B-2
Table B-2. React to a mass casualty incident	B-4
Table B-3. Establish a casualty collection point	B-8
Table B-4. Establish a patient decontaminate site	B-13
Table C-1. Army medical evacuation capabilities	C-1
Table C-2. Army casualty evacuation capabilities.....	C-2
Table C-3. United States Navy and Marine Corps casualty evacuation capabilities	C-3
Table C-4. United States Navy ship capabilities and staffing.....	C-4
Table C-5. United States Air Force aircraft capacities	C-6
Table C-6. Landing point uses	C-7
Table D-1. Medical platoon force health protection responsibilities	D-2
Table D-2. Medical readiness classification chart	D-6
Table E-1. Disease and nonbattle injury rates in contemporary operations	E-6
Table E-2. Additional battalion medical personnel training	E-11
Table E-3. Additional battalion nonmedical personnel training	E-12
Table F-1. Battalion-level echelons	F-1
Table F-3. Medical control points	F-10
Table F-4. Vehicle symbols	F-12
Table H-1. Department of the Army recordkeeping guidance.....	H-5

This page intentionally left blank.

Preface

This publication provides information on the structure and operation of medical platoons and sections that are organic to maneuver battalions and squadrons operating in a Role 1 capacity within a brigade combat team's area of operation. It is directed toward both the medical platoon leader and medical platoon sergeant and the conduct of medical operations from point of injury or casualty collection point thru the Role 1 battalion aid station. The tactics, techniques, and procedures provided are not all-inclusive. They provide a way of performing a particular mission, but may require modification based on mission, enemy, terrain, troops, time available, and civilian considerations.

This publication provides information on the medical organization of the division and how medical platoons and sections organic to the division provide Army Health System support in the form of force health protection and health service support. It outlines the responsibilities of the medical platoon or section. It provides definitive information and provides doctrinal tools on planning, rehearsing, and conducting Army Health System support at Role 1 battalion-level. It provides tactics, techniques, and procedures for directing, controlling, and managing Army Health System support at the platoon/section level. It describes the troop leading procedures and military decision-making processes required for Army Health System support operations and identifies interface and coordination requirements with other brigade medical elements.

This Army techniques publication (ATP) is not a stand-alone reference and will require the user to be familiar with Field Manual (FM) 4-02 and the ATP 4-02 and 4-25 series of publications and training circulars (TC) 4-02.1 and TC 4-02.3.

The principal audience for ATP 4-02.4 are all commanders and their staffs, command surgeons, medical planners, Army medical service personnel, and other medically qualified personnel assigned to maneuver forces that are executing and supporting Role 1 medical operations in a large-scale combat operations environment. It is to be used as a guide in both obtaining and providing Role 1 Army Health System support in a maneuver battalion's area of operations. Information in this publication is applicable to decisive actions in support of unified land operations. It is compatible with the Army's command and control, protection, and sustainment doctrine and is aligned with Joint Publication (JP) 4-02.

Commanders, staffs, and subordinates ensure that their decisions and actions comply with applicable United States, international, and in some cases host-nation laws and regulations. Commanders at all levels ensure that their Soldiers operate in accordance with the law of war and the rules of engagement (see FM 6-27/MCTP 11-10C).

The proponent and the preparing agency of ATP 4-02.4 is the United States Army Medical Center of Excellence, Directorate of Training and Doctrine, Doctrine Literature Division. Send comments and recommendations on a Department of the Army Form

2028 (*Recommended Changes to Publications and Blank Forms*) to **Commander, United States Army Medical Center of Excellence (MEDCoE), Attention: ATMC-FD (ATP 4-02.4), Building 4011, Suite B, 2377 Greeley Road, JBSA Fort Sam Houston, Texas 78234-7731**; by e-mail to usarmy.jbsa.medical-coe.mbx.ameddcs-medical-doctrine@mail.mil. All recommended changes should be keyed to the specific page, paragraph, and line number. A rationale for each proposed change is required to aid in the evaluation and adjudication of each comment.

When describing the responsibilities of the platoon leader, it will be referring to the Medical Service Corps officer. When describing the responsibilities of the physician, it will designate him as the battalion surgeon, field surgeon, doctor, or physician.

In the absence of a battalion surgeon, the PA assumes the clinical roles and responsibilities of the battalion surgeon.

Unless this publication states otherwise, the term brigade refers to regiment; battalion refers to squadron; headquarters and headquarters company refers to headquarters and headquarters battery or troop; and company refers to battery or troop.

This publication uses joint terms where applicable. Terms for which this publication is the proponent publication are marked with an asterisk (*) in the glossary.

This publication applies to the Active Army, the Army National Guard/Army National Guard of the United States, the United States Army Reserve, unless otherwise stated.

This publication implements or is in consonance with the following North Atlantic Treaty Organization (NATO) Standardization Agreements (STANAGs).

TITLE	NATO STANAG
<i>Documentation Relative to Initial Medical Treatment and Evacuation - Allied Medical Publication-8.1</i>	2132
<i>The Medical Management of CBRN Casualties - AMedP-7.1 Edition A</i>	2461
<i>Allied Joint Medical Planning Doctrine - AJMedP-1 Edition A</i>	2542
<i>Allied Joint Medical Doctrine for Medical Evacuation - AJMedP-2 Edition A</i>	2546
<i>Emergency Medical Care in the Operational Environment - AMedP-24</i>	2549
<i>Allied Joint Medical Force Health Protection Doctrine - AJMedP-4 Edition A</i>	2561
<i>Orders for the Camouflage of Protective Medical Emblems on Land in Tactical Operations - ATP-79</i>	2931
<i>Training of Medical Personnel for Chemical, Biological, Radiological, and Nuclear (CBRN) Defence - AMedP-7.3 Edition A</i>	2954
<i>Aeromedical Evacuation - AAMedP-1.1 Edition B</i>	3204
<i>Helipad and Heliport Marking and Lighting - AATMP-12 Edition A</i>	3619

Introduction

This publication comes at a time when the Army and operational medical forces are transitioning from limited contingency missions (counterinsurgency) to a large-scale combat operation focus. For this to occur, operational medical forces must execute a cultural shift. After two decades of supporting counterinsurgency operations, the current generation of Army Medical personnel lack familiarity with large-scale combat operations.

Within large-scale combat operations, the sheer scope of the multi-domain battlefield can cause amounts of casualties not seen since World War II. In large-scale combat operation, duties once performed by one member of the medical platoon are now performed by a different member. The decision of who performs what duties in the medical platoon are hard but required in this cultural shift as the medical support to the warfighter is the operational medical forces number one priority.

The material presented in this publication reflects enduring practices in providing timely Army Health System support to the tactical battalion commander. This publication depicts Army Health System operations from the point of injury or wounding, or from the casualty collection point through the Role 1 BAS.

The medical platoon is a unit assigned to multiple types of maneuver battalions within a brigade combat team. Each medical platoon possesses similar capabilities and functions but apply them in vastly different manners. To clearly delineate these types of units, and to detail the Army Health System support that medical platoons provide to the various types of military operations, this publication contains five chapters and eight appendices:

- Chapter 1, The Role of the Medical Platoon, provides a holistic view of the entire Army Health System within a brigade. It discusses the echelons above brigade medical forces that are in support of a brigade. This part of the publication describes the four types of brigades and their Army Health System support forces.
- Chapter 2, Command and Control, details the command and control requirements of the medical platoon leadership including, troop-leading procedures, the five paragraph operations order, the military decision-making process, risk management, rehearsals, precombat checks and inspections, and after action reviews.
- Chapter 3, Army Health System Support to Operations, discusses how medical platoons provide Army Health System support to operations and encompasses how the medical platoon will support its maneuver battalion during offensive, defensive, and stability operations. It also details Army Health System support to operations conducted at night, in an urban environment, in the jungle, in the

desert, during mountainous and cold weather operations, wet gap crossings, subterranean operations, and during airborne and air assault operations.

- Chapter 4, Sustainment, describes how the medical platoon performs platoon level sustainment operations, including medical supply.
- Chapter 5, Chemical, Biological, Radiological, and Nuclear Operations, details how the medical platoon supports itself and the battalion in chemical, biological, radiological, and nuclear operations to include establishing the patient decontamination site.
- Appendix A, Analog Reports, details common reports a medical platoon is required to submit.
- Appendix B, Medical Battle Drills, discuss medical-specific battle drills required by medical platoons to accomplish their mission effectively.
- Appendix C, Patient Evacuation, details casualty and medical evacuation platform litter and ambulatory capacities for Army, Marine Corps, Navy, and Air Force.
- Appendix D, Force Health Protection and Medical Readiness, provides considerations for the medical platoon mission of maintaining the Force Health Projection and medical readiness of the battalion.
- Appendix E, Medical Training Considerations, provides instructions on teaching combat lifesavers and field sanitation teams for the battalion. It also details required training for medical and nonmedical personnel performing these tasks.
- Appendix F, Battalion-Level Symbology, lists of common military symbols a medical platoon will come into contact with at the battalion-level.
- Appendix G, Law of Land Warfare and Medical Ethics, discusses medical implications of the Geneva Hague Conventions and medical ethics.
- Appendix H, Tactical Standard Operating Procedures, provides detailed instruction on how to establish platoon-level tactical standard operating procedures.

Based on doctrinal changes, terms for which Army Techniques Publication 4-02.4 is the proponent have been added for the purposes of this publication. The glossary contains acronyms and defined terms (see introductory Table-1 for specific term changes).

Introductory Table -1. Army terms

<i>Term</i>	<i>Current proponent publication</i>	<i>Move to new proponent publication</i>
Battalion aid station	ATP 4-02.3	ATP 4-02.4
Tailgate medical support	FM 4-02	ATP 4-02.4

Chapter 1

Role of the Medical Platoon

The maneuver battalion has organic medical resources in the form of the medical platoon. Slight differences exist between the medical capabilities/resources of the various types of brigade combat teams (infantry, armored, and Stryker). These differences, based upon the type of parent unit, are discussed but not in detail.

Contents		
SECTION I	Role 1 Army Health System Overview	Page 1-1
SECTION II	Threats	1-15
SECTION III	Medical Platoon Capabilities and Key Personnel	1-19
SECTION IV	Medical Platoon Task Organization	1-31
SECTION V	Employment of the Medical Platoon	1-36
SECTION VI	Brigade and Echelons above Brigade Medical Assets in Support of the Medical Platoon	1-59

SECTION I – ROLE 1 ARMY HEALTH SYSTEM OVERVIEW

1-1. The medical platoon, also referred to as battalion aid station (BAS), coordinates the Army Health System (AHS) support operations for the battalion commander. The ***battalion aid station is a forward-most medically staffed treatment location organic to a maneuver battalion.*** It is uniquely organized, trained, and equipped to conduct medical treatment and evacuation tasks.

MEDICAL PLATOONS IN DECISIVE ACTION

1-2. The role of the medical platoon is to ensure the force health protection (FHP) of the battalion, to perform health service support (HSS) by conducting medical treatment, conduct medical evacuation (MEDEVAC), to ensure plans for Class VIII resupply are incorporated into the battalion plan. These tasks provide a ready medical force and preserve Soldier lethality allowing commanders to make decisions.

1-3. The execution of AHS support operations provides units with the will to fight knowing that well-trained and dedicated medical personnel stand ready to execute a medical treatment and evacuation plan tailored to the mission and able to adjust to the changing situation, react to opportunities and danger, and enable commanders to

transition to future operations. For example, medical platoons coordinate MEDEVAC to higher roles of care that allow commanders to quickly transition from defense to offense by clearing the battlefield of casualties. By splitting the battalion aid station (BAS), medical platoons provide the commander with medical elements that can support bounding operations of two separate efforts. Medical platoons assist the commander to preserve Soldier lethality, willingness to fight, and preserve freedom of maneuver.

1-4. Medical platoons are the only organic medical capability available to armor, combined arms, infantry, and Stryker battalions. By providing mobile, flexible, and proximal AHS support, commanders are assured that the medical treatment and evacuation of their Soldiers is taken care of and that they and their staff can concentrate on the operational aspects of fighting the battalion.

1-5. Medical platoons execute missions with organic and attached assets to treat and medically evacuate patients from point of injury (POI) to the Role 1 BAS. When performing its fundamental role, the medical platoon makes the following contributions (not in order of priority):

- Coordinate the operations, administration, and battalion-level medical logistics (MEDLOG) (Class VIII) for the medical platoon and combat lifesavers (CLS).
- Establish the BAS as far forward as possible.
- Provide triage and Role 1 emergency medical care and treatment.
- Provide tactical combat casualty care (TCCC).
- Locate and acquire (collect) patient(s).
- Provide MEDEVAC.
- Coordinate and facilitate aeromedical evacuation (AE).
- Ensure FHP tasks are planned and conducted to include disease and nonbattle injury (DNBI) prevention.
- Identify health threats and medically related commander's critical information requirement (CCIR).
- Provide combat medics for the two combat platoons in the headquarters and headquarters company (HHC) (scout and mortar) and each infantry rifle company.
- Conduct (on order) patient decontamination operations.

1-6. The medical platoon operates in direct support of a larger force, which may include offensive, defensive, or stability operations. It operates consistent with and guided by the six AHS principles during planning, preparation, and execution of its missions. The primary focus of the medical platoon is to treat and evacuate patients. Listed below are the primary tasks and purposes of the Role 1 medical treatment (organic and area support) and MEDEVAC functions (see tables 1-1 and 1-2).

1-7. For additional information on MEDEVAC and medical regulating, refer to JP 4-02, Army Regulation (AR) 40-3 and ATP 4-02.2.

Table 1-1. Primary tasks and purposes of the Role 1 medical platoon, medical treatment (organic and area support) function

<i>Primary task</i>	<i>Purpose</i>
Provide first aid	Decrease killed-in-action rate. This task is performed by nonmedical Soldiers performing self-aid/buddy aid, and/or combat lifesaver support prior to arrival of the combat medic and/or other health care personnel.
Provide tactical combat casualty care	Provide lifesaving intervention at the point of injury or wounding. This task is performed by the combat medic who locates, acquires, stabilizes, and evacuates patients with combat trauma. At echelons above brigade, this task is referred to as emergency medical treatment in noncombat operations.
Conduct routine sick call	Provide primary care services as close to patient's unit as possible.
Promote casualty prevention measures	Promote wellness and enhance Soldier medical readiness to decrease morbidity and mortality. There are no operational public health or combat and operational stress control assets at Role 1; however, they are available at Role 2.
Provide medical evacuation	Provide medical evacuation by ground ambulance on an area support basis and to provide en route medical treatment during transport.

Table 1-2. Primary tasks and purposes of the Role 1 medical platoon, medical evacuation function

<i>Primary task</i>	<i>Purpose</i>
Acquire and locate	Provide a rapid response to acquire wounded, injured, and ill personnel. Clear the battlefield of casualties and facilitate and enhance the tactical commander's freedom of movement and maneuver. This task is performed by the medical evacuation crew of the evacuation platform.
Treat and stabilize	Maintain or improve the patient's medical condition during transport and provide en route care as required. This task is performed by medical evacuation crewmembers and providers when necessary.
Provide intra-theater medical evacuation	Provide rapid evacuation utilizing dedicated assets to the most appropriate role of care. Provide a capability to cross-level patients within the theater hospitals and to transport patients being evacuated out of theater to staging facility prior to departure. This task is performed by the evacuation platforms in the medical company (ground ambulance) and medical company (air ambulance).
Provide emergency movement of medical personnel, equipment, and supplies	Provide a rapid response for the emergency movement of scarce medical resources throughout an operational environment.

VARIABLES OF THE OPERATIONAL ENVIRONMENT

1-8. The operational environment (OE) evolves as each operation progresses. The two types of variables are operational and mission. Army leaders use operational variables to analyze and understand a specific OE and use mission variables to focus on specific elements during mission analysis. See Army Doctrine Publication (ADP) 3-0 for more information. The operational variables are political, military, economic, social, information, infrastructure, physical environment, and time. Refer to ADP 5-0 for more information.

1-9. Mission variables are characteristics of the area of operations (AO) and how they affect a mission. The mission variables are mission, enemy, terrain and weather, troops and support available, time available, and civil considerations (METT-TC). Refer to ADP 5-0 for more information.

WARFIGHTING AND MEDICAL FUNCTIONS

1-10. The AHS medical capabilities (10 medical functions) align with medical disciplines and scientific knowledge. They are grouped under three Army warfighting functions: FHP under protection, HSS under sustainment, and medical command and control under command and control warfighting functions. To clearly delineate which medical functions are grouped under which warfighting function, the Army is aligning with the joint Services (according to JP 4-02) in grouping these 10 medical functions (see figure 1-1).

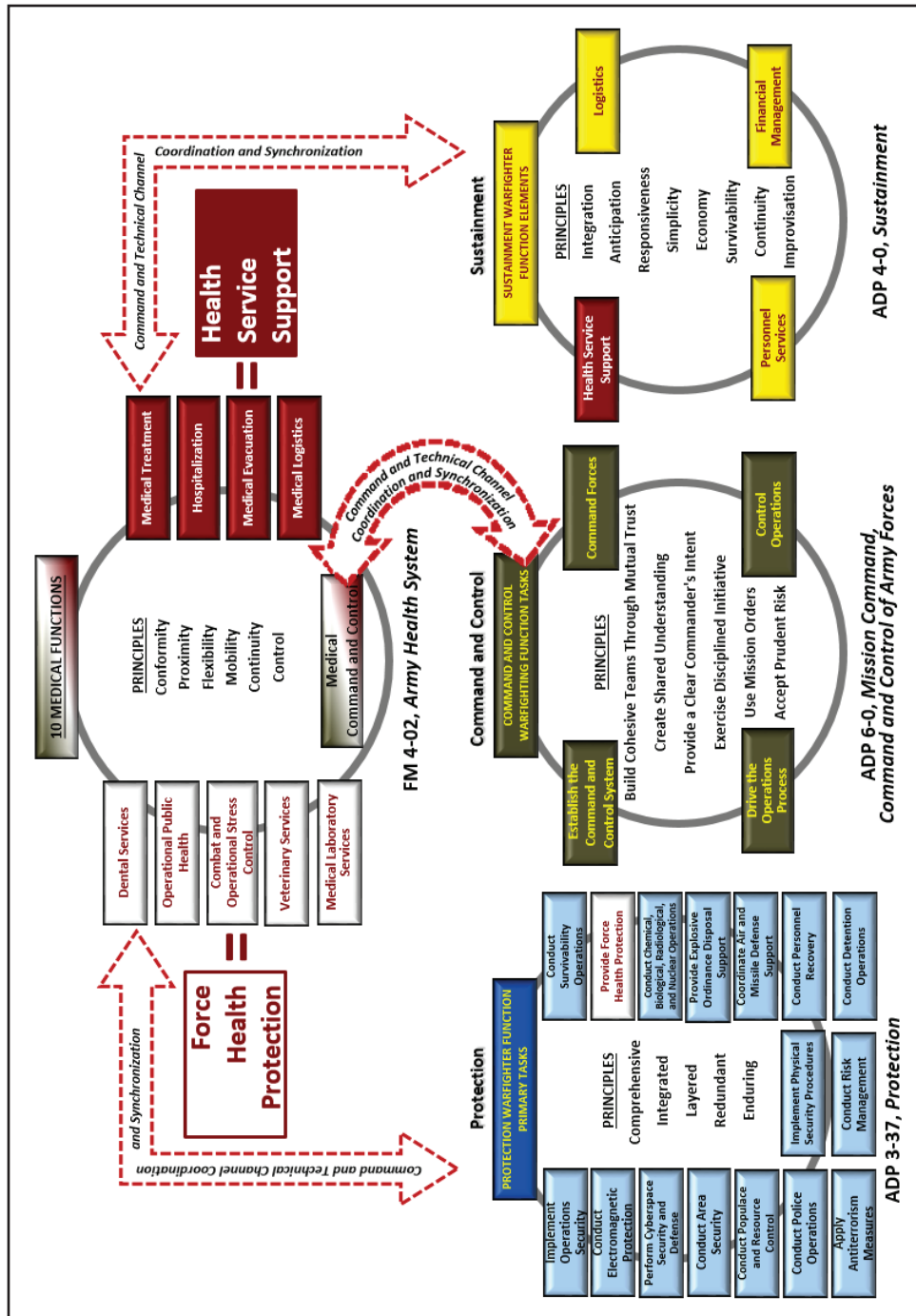

Figure 1-1. Medical function to warfighting function linkage

FORCE HEALTH PROTECTION MISSION

1-11. The *Army force health protection* are measures that promote, improve, or conserve the behavioral and physical well-being of Soldiers comprised of preventive and treatment aspects of medical functions that include: combat and operational stress control (COSC), dental services, veterinary services, operational public health, and laboratory services. Enabling a healthy and fit force, prevent injury and illness, and protect the force from health hazards. (FM 4-02). This enables a healthy and fit force, prevents injury and illness, and protects the force from health hazards. For more information on protection see ADP 3-37. The medical functions aligned with the FHP mission component of AHS are:

- Dental services promote dental health; prevent and treat oral and dental disease; provide far forward dental treatment; provide early treatment of severe oral and maxillofacial injuries; and augment medical personnel (as necessary) during mass casualty (MASCAL) operations. See ATP 4-02.19 for more information.
- Operational public health is the science and practice of promoting, protecting, improving, and, when necessary, restoring the health of individuals, specified groups, or the entire population. It is a major enabler for Army readiness and a major component of FHP in its application throughout all Army activities. Levels of readiness and health in all Army populations are enhanced and sustained by applying the principles of public health to promote healthy behaviors and to prevent and minimize the impacts of diseases and injuries. When emphasized by commanders and unit leaders, operational public health can effectively reduce and prevent DNBI and maximize the fighting strength of the operational force. For more information regarding the Army Public Health Program and operational public health, refer to AR 40-5 and DA PAM 40-11. See FM 4-02 and ATP 4-02.8 for more information on operational public health.
- Combat and operational stress control has always been a commander's program. To be successful, commanders must fully understand and appreciate the magnitude of a potentially traumatic event as it affects exposed organizations and individuals. It is a harsh reality that combat and operational stress affects everyone engaged in unified land operations. It should be viewed as a continuum of possible outcomes, ranging from positive growth behaviors to negative and sometimes disruptive reactions that each person will experience. Effective leadership shapes the experience that leaders and their Soldiers go through in an effort to successfully transition units and individuals, build resilience, and promote posttraumatic growth, or increased functioning and positive change, after enduring trauma. The COSC does not take away the experiences faced while engaged in military operations, it attempts to mitigate those experiences so that Soldiers and units remain combat-effective and ultimately provide the support and meaning that will allow Soldiers to maintain the quality of life to which they are entitled. See FM 4-02 and ATP 4-02.8 for more information on COSC.

- Veterinary service is essential for FHP including maintaining the health and welfare for military working animals and other animals entitled to veterinary care by the United States Army; food protection and veterinary public health missions; and the training, equipping, and deploying of the veterinary force; in order to project and sustain a healthy and medically protected force and promote the health of the Soldier. The United States Army is the sole provider for veterinary services for all Services (DODD 6400.04E) (with the exception of food inspection operations on USAF installations). See FM 4-02 and ATP 4-02-8 for more information on Veterinary Services.
- Medical laboratory services include both clinical laboratories and environmental laboratories. See FM 4-02 for more information on laboratory services. Discussed below are where the medical platoon would find laboratory services—
 - Clinical laboratory capabilities can be found starting at Role 2 medical companies, although they are very limited in the tests that can be run.
 - The Role 3 hospital center or field hospital has robust laboratory capabilities, including microbiology.
 - Occupational and environmental health hazards, risks, and exposures are assessed and documented using operational public health laboratory services provided by echelons above brigade (EAB) units, to include the Area Medical Laboratory and the United States Army Public Health Center.

HEALTH SERVICE SUPPORT MISSION

1-12. The Army *health service support* is support and services performed, provided, and arranged by the Army Medicine to promote, improve, conserve, or restore the behavioral and physical well-being of personnel by providing direct patient care that include medical treatment (organic and area support) and hospitalization, medical evacuation to include medical regulating, and medical logistics to include blood management. (FM 4-02). Health service support includes the treatment of chemical, biological, radiological, and nuclear (CBRN) patients. The medical functions aligned with the HSS mission component of AHS are:

- Medical treatment (organic and area support) encompasses Role 1 medical treatment support. This role of care is provided by the medical platoons of maneuver forces. The area support function encompasses TCCC, routine sick call, emergency dental care, operational public health, and COSC support.
- Hospitalization is a part of the theater-wide AHS support for managing sick, injured, and wounded personnel. The term hospitalization is used to describe that portion of health care delivery provided at hospitals for all classes of patients whose conditions cannot be managed on an outpatient or patient holding status. This constitutes the Role 3 hospital center or field hospital in a theater of operations. Role 4 MTFs are a part of the AHS and are located outside of a theater. See ATP 4-02.10 for more information on theater hospitalization.

- *Medical evacuation* (to include medical regulating) is the timely and effective movement of the wounded, injured, or ill to and between medical treatment facilities on dedicated and properly marked medical platforms with en route care provided by medical personnel. Also called MEDEVAC (ATP 4-02.2). See ATP 4-02.2 for more information on MEDEVAC.
- Medical logistics (to include blood management) is an integral part of the AHS. It provides intensive life cycle management of medical products and services that are used almost exclusively by the AHS and are critical to its success. Army MEDLOG support anticipates the needs of the customer and is tailored to continuously provide end-to-end sustainment of the AHS support mission throughout the competition continuum. See ATP 4-02.1 for more information on MEDLOG.

MEDICAL COMMAND AND CONTROL MISSION

1-13. Medical command and control is functionally aligned with the command and control warfighting function. The nine interrelated and interdependent medical functions listed above are complex in nature and require medical command and control for synchronization and integration. The medical command and control function includes the centralized medical chain of command that provides command and control of EAB medical assets. *Command and Control* is the exercise of authority and direction by a properly designated commander over assigned and attached forces in the accomplishment of the mission. Also called C2. (JP 1). Most importantly, it includes the battalion surgeon's technical supervision of assigned or attached medical assets. This ensures the interrelationships and interoperability of all medical assets and optimizes the effective functioning of the entire system.

ARMY HEALTH SYSTEM PRINCIPLES

1-14. The AHS principles (see figure 1-2) are used by medical planners when developing concepts of support and running estimates during military decision-making process (MDMP). It is not likely for a concept of support to be advantageous in all six of the AHS principles; therefore, it is crucial that medical planners understand the commander's intent. For example, splitting the BAS into treatment teams A and B is an action that provides flexibility and proximity, however, control and continuity may be hindered.

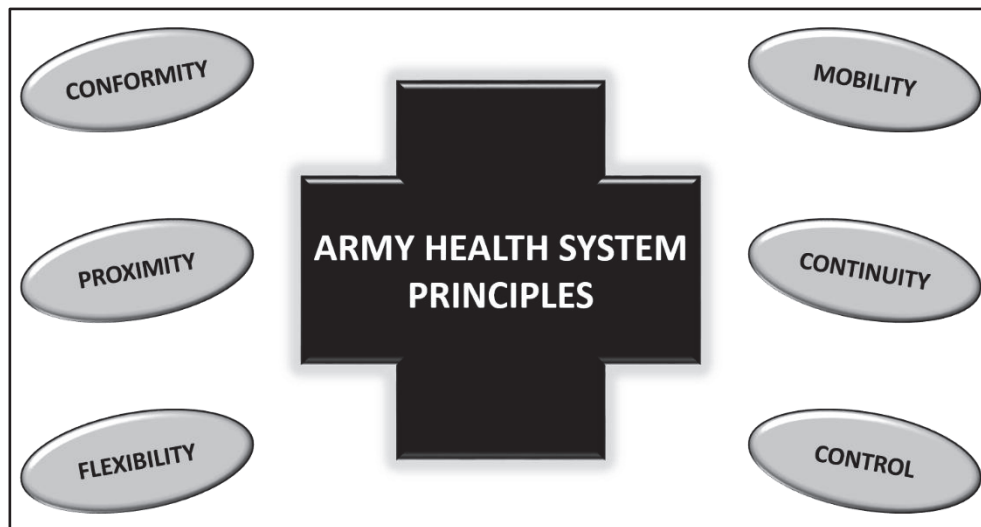

Figure 1-2. Army Health System principles

CONFORMITY

1-15. Conformity with the maneuver plan is the most basic element for effectively providing AHS support. The medical planner must be able to balance current operations and future operations to effectively integrate an AHS support plan into the maneuver plan. Certain factors must be considered:

- Do all the operational terms make sense? The difference between isolate and assault are going to change the medical plan.
- Which element is the decisive operation?
- What are each of the shaping operations' tasks and purposes?

PROXIMITY

1-16. Proximity ensures AHS assets are placed within supporting distance of the maneuver forces they are supporting, but not so as to impede ongoing operations. Placement of AHS assets are METT-TC dependent, however, a tactics, techniques, and procedures (TTP) for planning purposes is to establish the casualty collection point (CCP) 1-3 kilometers (.6 to 1.8 miles) or one terrain feature from the forward line of own troops (FLOT); Role 1, 5-7 kilometers (3.1 to 4.3 miles) or two terrain features from the FLOT; and Role 2, 20-25 kilometers (12.4 to 15.5 miles) from the FLOT. Proximity to the FLOT is often favored however, certain factors must be considered.

- What kind of security is available?
- If the Role 1 BAS is not collocated with the combat trains command post (CTCP) then what is the resupply plan?
- What terrain features are going to hinder the enemy but enable friendly forces?

FLEXIBILITY

1-17. Flexibility is being prepared to, and empowered to, shift AHS support resources to meet changing requirements. Changes in plans or operations make flexibility in AHS support planning and execution essential. This ability to rapidly re-mission these special skills maximizes the lifesaving capacity of these units, provides the highest standard of lifesaving medical interventions to the greatest number of combat wounded, and enhances the effectiveness of the medical treatment and evacuation provided and the productivity of the platoon. Some questions to consider are:

- Is the Role 1 BAS capable of splitting and/or is it necessary?
- Will capacity be impacted if the BAS splits?
- What assets like evacuation platforms can be moved to increase some of the other principles, increase sustained care, or more rapidly build combat power?

MOBILITY

1-18. Mobility is the principle that ensures that AHS assets remain in supporting distance of maneuvering forces. Therefore, to facilitate a continuous evacuation flow, MEDEVAC must be a synchronized effort to ensure timely, responsive, and effective support is provided to the tactical commander. Mobility of AHS assets is often overlooked as an element of security. Some questions the medical platoon must consider are:

- Is set up/tear down of the Role 1 BAS a practiced standard operating procedure (SOP)?
- Are there dedicated casualty evacuation (CASEVAC) platforms ready for evacuation or are they full of equipment?
- What is the bump plan if a vehicle breaks down or is destroyed?
- Is a plan in place in case the Role 1 BAS needs to jump, but has too many patients or died of wounds in their care?
- What is the plan to move patients in order to maintain mobility?

CONTINUITY

1-19. Continuity in care and treatment is achieved by moving the patient through progressive, phased roles of care, extending from the POI to the Role 2. Some questions to consider are:

- How are patients tracked? Do all units within the brigade combat team (BCT) use the same system?
- If a Role 1 BAS splits, are both treatment teams providing treatment and evacuation?
- Is there a standard patient handoff brief?

CONTROL

1-20. Control is required to ensure scarce AHS support resources are efficiently employed and support the plan. Control necessitates that the medical functions within

a BCT are synchronized to ensure the complex interrelationships and interoperability of all medical assets remain in balance to optimize the effective functioning of the entire system. Some questions to consider are:

- What reports are due and to whom? Is feedback desired from the information given?
- If assets are pushed forward is too much control given up?
- Who is in charge of medical regulation? How does this determine patient distribution?

ROLES OF MEDICAL CARE

1-21. A basic characteristic of organizing modern AHS support is the distribution of medical resources and capabilities to facilities at various levels of command, diverse locations, and progressive capabilities, which are referred to as roles of care.

1-22. As a general rule, no role of care will be bypassed except on grounds of medical urgency, efficiency, or expediency. The rationale for this rule is to ensure the stabilization/survivability of the patient through TCCC. See figure 1-3 for a brief description of the roles of care.

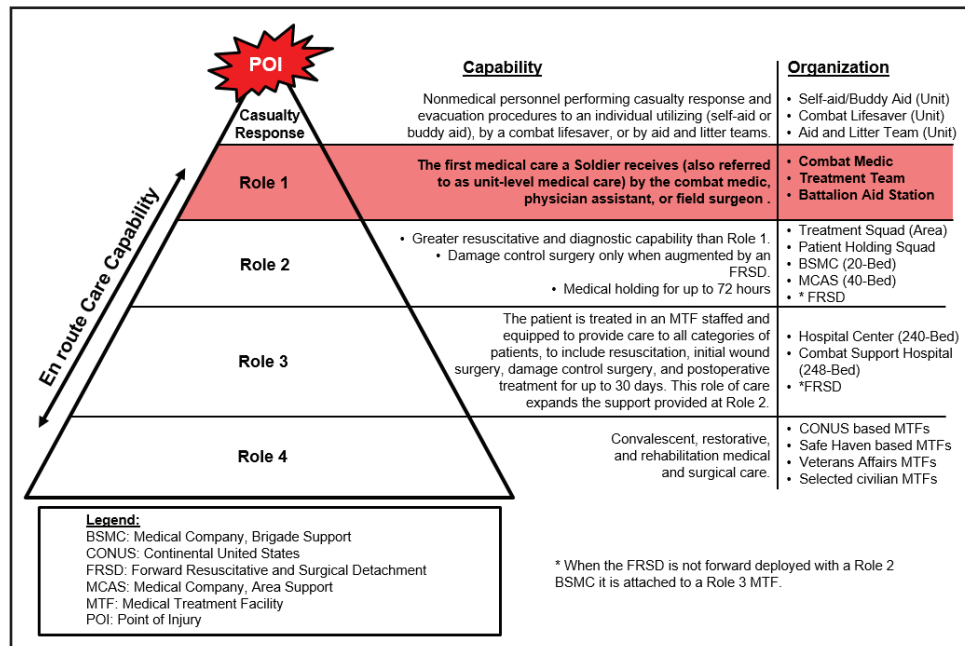

Figure 1-3. Army Health System roles of care

1-23. The medical platoon is primarily concerned with the first three roles of care, nonmedical personnel, Role 1, and Role 2 care. Discussed below are these three roles of care.

NONMEDICAL PERSONNEL

1-24. Nonmedical personnel performing first aid procedures assist the combat medics in their duties. First aid is administered by an individual (self-aid or buddy aid) and enhanced first aid is provided by the combat lifesavers. A CLS is a nonmedical Soldier of a unit trained to provide enhanced first aid as a secondary mission. See appendix E for more information on the CLS.

Self-Aid and Buddy Aid

1-25. Each individual Soldier is trained in a variety of specific first aid procedures. These procedures include aid for chemical casualties with particular emphasis on lifesaving tasks. This training enables the Soldier or a buddy to apply first aid to alleviate potential life-threatening situations. Each Soldier is issued an individual first aid kit to accomplish first aid tasks. First aid (self-aid/buddy aid) refers to urgent and immediate lifesaving and other measures which can be performed for casualties (or performed by the victim themselves) by nonmedical personnel when medical personnel are not immediately available.

Combat Lifesaver

1-26. The CLS is a nonmedical Soldier selected by the unit commander for additional training beyond basic first aid procedures. A minimum of one individual per squad, crew, team, or equivalent-sized unit should be trained. The primary duty of this individual does not change. The additional duty of the CLS is to provide enhanced first aid for injuries, based on their training, before the combat medic arrives. Combat lifesaver training is normally provided by medical personnel during direct support of the unit. The training program is managed by the senior medical person designated by the commander.

Role 1

1-27. The first medical care a Soldier receives is provided at Role 1 BAS (also referred to as unit-level medical care). This role of care includes:

- Immediate lifesaving measures.
- Disease and nonbattle injury prevention.
- Combat and operational stress preventive measures.
- Patient location and acquisition (collection).
- Medical evacuation from supported units (POI or wounding, company aid posts, or CCP) to supporting Role 2 medical company, brigade support (BSMC).
- Treatment provided by designated combat medics or treatment squads. (Major emphasis is placed on those measures necessary for the patients to return to duty or to stabilize them and allow for their evacuation to the next role of care.

1-28. Role 1 medical treatment is provided by the combat medic or by the physician, the physician assistant, or the health care specialist in the battalion aid station/Role 1

BAS. ***Emergency medical treatment*** refers to the immediate application of medical procedures to the wounded, injured, or sick by specially trained medical personnel.

Role 1 includes:

- Tactical combat casualty care (immediate far forward care) consists of those lifesaving steps that do not require the knowledge and skills of a physician. The combat medic is the first individual in the medical chain that makes medically substantiated decisions based on medical military occupational specialty-specific training.
- At the Role 1 BAS, the physician and the physician assistant are trained and equipped to provide TCCC to the patient. This element also conducts routine sick call when the operational situation permits.
- During ground MEDEVACs, Role 1 treatment is provided by the ambulance aide/driver.

Role 2

1-29. At this role, care is rendered at the Role 2 BSMC which is operated by the treatment squad (area), area support squad, and patient holding squad of the medical treatment platoon. Here, the patients are examined and their wounds and general medical condition are evaluated to determine their treatment and evacuation precedence, among other patients. Medical treatment including trauma management and beginning resuscitation is continued, and if necessary, additional emergency measures are instituted, but they do not go beyond the measures dictated by immediate necessities. The Role 2 BSMC provides a greater capability to resuscitate trauma patients than is available at Role 1 BAS. Those patients who can return to duty within 72 hours are held for treatment. This role of care provides MEDEVAC from Role 1 BASs and also provides Role 1 medical treatment on an area support basis for units without organic Role 1 resources. The Role 2 BSMC has the capability to provide packed red blood cells (liquid), limited x-ray, clinical laboratory, operational dental support, COSC, operational public health, and when augmented, physical therapy and optometry services.

TACTICAL COMBAT CASUALTY CARE

1-30. Tactical Combat Casualty Care is the Department of Defense (DOD) standard of care for first responders (medical and nonmedical) and the All Service Member TCCC course replaces Service trauma skills currently taught in first aid and self-aid/buddy care courses. Training all Service members in TCCC fulfills the following Joint Requirements Oversight Council Memorandums (JROCMs): JROCM 025-15, JROCM 031-14, and JROCM 048-15. All Service members receive role-based TCCC training and certification in accordance with the skill level (such as all Service Members, CLS, combat medic/corpsmen, and combat paramedic/provider) outlined by the Joint Trauma System, the DOD's center of excellence for trauma as designated in DOD Instruction (DODI) 6040.47 and DODI 1322.24.

1-31. Current TCCC Guidelines can be found on the deployed medicine website. These guidelines are routinely updated and the website should be referenced to ensure training compliance. The TCCC Guidelines are the standard of care for the modern battlefield.

1-32. The Joint Trauma System is focused on the standard of care for prehospital battlefield medicine. The Joint Trauma System is a DOD Center of Excellence for Trauma providing clinical practice guidelines and performance improvement for all levels of military trauma care. The Committee on TCCC consists of representatives from across the Army, Marines, Navy, and Air Force positioned under the Joint Trauma System that establishes clinical practice guidelines for the delivery of TCCC on the battlefield.

1-33. Prehospital trauma care in tactical settings is very different from civilian settings. Tactical and environmental factors have a profound impact on trauma care rendered on the battlefield. Good medicine can be bad tactics. Tactical combat casualty care training gives medical personnel the required skills they need in a tactical environment.

1-34. First responder care is critical. The Journal of Special Operations Medicine states that up to 24 percent of combat deaths are potentially preventable; therefore, first responder care is paramount. Improvements in how the force approaches the combat casualty have resulted in significantly lower death rates in combat.

1-35. The three phases of care in TCCC are:

- Care under fire (CUF) — CUF is the very limited care that can be provided while the casualty and the provider are under effective enemy fire.
- Tactical field care (TFC) — TFC is performed on the battlefield, but not under effective enemy fire.
- Tactical evacuation care (TACEVAC) — TACEVAC is rendered during transport off the battlefield on the way to more definitive care.

1-36. The TCCC guidelines cover CUF, TFC, and TACEVAC. These recommendations are intended to be guidelines only and are not a substitute for clinical judgment.

CASUALTY EVACUATION

1-37. *Casualty evacuation* is the movement of casualties aboard nonmedical vehicles or aircraft without en route medical care. Also called CASEVAC (FM 4-02). Casualty evacuation encompasses a wide spectrum of potential capability: depending on the mix of transport platform, medical equipment, and medical providers allocated to the mission. At the upper end of the spectrum, nondedicated platforms can be outfitted with the requisite medical equipment and personnel. At the lower end of the spectrum, CASEVAC can be no more than the transport of casualties using platforms of opportunity with no medical equipment or medical providers (in using such assets, the risk of not moving the casualty must outweigh the risk evacuating them in such a manner). Effective CASEVAC complements MEDEVAC by providing additional evacuation capacity when number of casualties (workload) or reaction time exceeds the capabilities of MEDEVAC assets. Casualty evacuation requires detailed assessment, planning, coordination, and rehearsal in order to achieve an effective integration of

MEDEVAC and CASEVAC capabilities. See ATP 4-25.13 for more information on CASEVAC, and refer to ATP 4-02.2 for additional information on MEDEVAC.

WARNING

Casualties transported in CASEVAC platform may not receive proper en route medical care or be transported to the appropriate Role of care that can best address the casualty's medical needs. This may have an adverse impact on the casualty's prognosis, and long-term disability or even death may result.

MEDICAL EVACUATION

1-38. The Army MEDEVAC system is composed of dedicated, standardized MEDEVAC platforms (ground and air ambulances). These ambulances have been designed, staffed, and equipped to provide en route medical care to patients being evacuated and are used exclusively to support the medical mission, in accordance with the law of land warfare and the Geneva Conventions. The focus of the MEDEVAC mission coupled with the dedicated ambulances permits a rapid response to calls for medical support. The provision of en route care on medically equipped vehicles or aircraft greatly enhances the patient's potential for recovery and may reduce long-term disability by maintaining the patient's medical condition in a more stable manner. *En route care* is the care required to maintain the phased treatment initiated prior to evacuation and the sustainment of the patient's medical condition during evacuation. (ATP 4-02.2). A *patient* is a sick, injured or wounded individual who receives medical care or treatment from medically trained personnel (FM 4-02).

1-39. As the only Service with dedicated air ambulances, the United States Army, in accordance with DOD Directive 5100.01, provides intratheater AE to all land maneuver forces (once ashore) and provides support to ship-to-shore and shore-to-ship patient movement requirements.

SECTION II – THREATS

1-40. A *threat* is any combination of actors, entities, or forces that have the capability and intent to harm United States forces, United States national interests, or the homeland (ADP 3-0). Threats may include individuals, groups of individuals, paramilitary or military forces, nation-states, or national alliances. In general, threats are an enemy or an adversary. The difference between these two are:

- An *enemy* is a party identified as hostile against which the use of force is authorized (ADP 3-0).
- An enemy is also called a combatant and is treated as such under the law of war.

- An *adversary* is a party acknowledged as potentially hostile to a friendly party and against which the use of force may be envisaged (JP 3-0).

1-41. Army Medicine views threats from two perspectives: the general threat and the health threat. Although Army Medicine's primary concern is the health threat, the general threat must also be fully considered as it influences the—

- Character, types, and severity of wounds and injuries to which our forces may be exposed.
- Enemy's ability and willingness to disrupt AHS support operations and to respect the conditions of the Geneva Conventions in regards to the protection of AHS support personnel while engaged in their humanitarian mission.

REGULAR AND IRREGULAR THREAT DESCRIPTION

1-42. Regular threats. These include peer and near-peer threats that train, equip, and organize to conduct combined arms maneuver. They employ modern and modernized weapons systems capable of defeating or competing with like United States systems.

1-43. Irregular threats. These include insurgent, guerilla, terrorist, paramilitary, and criminal organizations. These threats attempt to win by exhausting United States national will by inflicting long-term expenditure of American lives and treasure. See FM 3-24 for more information on irregular threats. A hybrid threat employs a combination of regular and irregular forces. See TC 7-100 series and supporting products for more information on hybrid warfare, threat equipment, and potential operating environments.

HEALTH THREAT

1-44. An *operational environment* is a composite of the conditions, circumstances, and influences that affect the employment of capabilities and bear on the decisions of the commander. Also called OE (JP 3-0). The OE has a number of threats that consist of enemies, adversaries, neutrals, and hybrid threats (force that combines traditional, irregular, disruptive, or catastrophic capabilities). These threats are protracted confrontation among individuals, groups of individuals, paramilitary or military forces, state actors, and nonstate actors increasingly willing to use violence to achieve their political and ideological ends. There is a probability that, in the future, United States Army forces will conduct operations in an urban environment and in and around megacities. Urban areas are becoming safe havens and support bases for terrorists, insurgents, or criminal organizations.

1-45. Commanders and staffs analyze an OE using the eight operational variables comprised of political, military, economic, social, information, infrastructure, physical environment, and time. See FM 6-0 for more information on the operational variables.

1-46. The health threat is a composite of ongoing or potential enemy actions; adverse environmental, occupational, and geographic and meteorological conditions; endemic and emerging diseases; and employment of CBRN weapons (to include weapons of mass destruction that have the potential to affect both short and long-term health [including psychological impact] of personnel). The National Center for Medical Intelligence

(NCMI) website provides foundational baseline medical intelligence assessments and products on the following topics:

- Infectious disease and health threats.
- Pandemic warning.
- Health hazards due to chemicals and radiation.
- Military medical capabilities.
- Medical science and technology developments.
- Biosurveillance and biosafety.
- Medical countermeasures.

1-47. As an intelligence organization, NCMI produces the majority of its intelligence analysis at the classified level, which can be found on the NCMI website and the Joint Worldwide Intelligence Communications System website. Current and historical infectious-disease-related information to produce dynamic infectious disease risk assessments can also be found on the NCMI website. The health threat faced by deployed United States forces is depicted in table 1-3 on page 1-18. (see FM 4-02 and ATP 4-02.8 for more information).

Table 1-3. Health threat

<i>Injuries</i>	Musculoskeletal injuries (for example, performing AOC/MOS related tasks, physical training, and recreational activities)
<i>Diseases</i>	Endemic, emerging, epidemic, and pandemic Foodborne Fomites Waterborne Arthropodborne Zoonotic Breeding grounds for vectors
<i>Occupational and environmental health hazards</i>	Climatic (heat, cold, humidity, and significant elevations above sea level) Toxic industrial materials Accidental or deliberate dispersion of chemical, biological, and radiological material Disruption of sanitation services/facilities (such as sewage and waste disposal) Effects of industrial operations and industrial and operational noise
<i>Poisonous or toxic flora and fauna</i>	Toxic or poisonous plants, bacteria, and fungus Poisonous reptiles, amphibians, arthropods, and animals
<i>Medical effects of weapons</i>	Conventional (to include blast and mild traumatic brain injury/concussion) Improvised (to include improvised explosive devices) Chemical, biological, radiological, and nuclear warfare agents Directed energy Weapons of mass destruction Thermal (from nuclear blast or direct energy) Combined injury (chemical, biological, radiological agent plus thermal, blast, explosive, or projectiles)
<i>Physiologic and psychological stressors</i>	Continuous operations Combat and operational stress reactions Wear of mission-oriented protective posture ensemble Stability tasks Home front issues
Legend: AOC area of concentration MOS military occupational specialty	

THREAT IMPACT ON MEDICAL UNITS

1-48. Medical treatment and evacuation near the FLOT will be subjected to every possible threat. The threat to medical treatment and evacuation at the maneuver battalion will vary according to the intensity and location of the conflict. Large-scale combat operations (LSCO) are characterized by broad frontages, deep targets, and enemy penetrations of varying depths. Shape, prevent, and consolidate gains operations would be characterized by poorly defined frontages, dismounted operations conducted at varying depths, and support area security issues. Each environment will provide opportunities for deep strikes, long-range unconventional operations, and terrorism/sabotage. Therefore, prepared airfields, permanent bases, and fixed support facilities can be expected to become primary targets for opposing forces. The medical platoon will be exposed to hostile environments of multiple threats including—

- Direct interdiction by enemy armored combat vehicles or dismounted enemies.
- Damage and destruction by massive artillery/rocket fires.
- Damage or destruction from bombs, land mines, or even direct attack.
- Danger from enemy fixed and rotary wing tactical aircraft, more significant for the Role 1 BAS with both ground and air evacuation assets.
- Evacuation assets encountering air defense and conventional artillery, armored combat vehicles, and tactical aircraft.
- Anti-aircraft artillery and surface-to-air missiles (air ambulances will be continually under this threat).
- Electronic and cyber warfare, which may include spoofing or jamming to deny effective communication and navigation.
- Use of chemical, biological, and nuclear weapons.
- Terrorist activities.
- Unconventional warfare.

SECTION III – MEDICAL PLATOON CAPABILITIES AND KEY PERSONNEL

1-49. This section describes the common capabilities and duties and responsibilities of key personnel within a medical platoon.

COMMON MEDICAL PLATOON CAPABILITIES

1-50. A medical platoon is organic to each maneuver battalion HHC. The medical platoon has a set of common capabilities they perform in support of the battalion. How these capabilities are accomplished is dependent on the type of brigade assigned.

1-51. The following capabilities apply to all types of medical platoons. Each medical platoon can:

- Plan battalion-level AHS support operations utilizing MDMP.
- Plan medical platoon operations using troop leading procedures (TLP).

- Establish the BAS as far forward as possible, performs triage, and provides medical treatment within its capabilities.
- Conduct TACEVAC/MEDEVAC operations with organic MEDEVAC vehicles from the CCP to the BAS when required.
- Provide combat medics to the two combat platoons in the HHC (scout and mortar) and each infantry rifle company to ensure casualties are properly treated in the forward area.
- Conduct medical resupply of Class VIII for the BAS, ambulance squad, combat medic section, and CLS.
- Train the battalion in—
 - Tactical combat casualty care.
 - Evacuation (TACEVAC/CASEVAC/MEDEVAC procedures).
 - Combat lifesavers.
 - Field sanitation teams.
 - Personal hygiene.
 - Health threats.
 - Prevention of stress on Soldiers.
 - Patient decontamination procedures.
- Communicate and report information by voice and data over distances normally associated with beyond line-of-sight communications.
- Operate in close proximity to the enemy and among civilian populations.
- Integrate attachments and augmentation to execute the battalion's AHS support plan.
- Move at speeds equal to or faster than the supported unit.
- Lead and train squads and teams with noncommissioned officers (NCOs).

DUTIES AND RESPONSIBILITIES BY TITLE

1-52. The platoon is organized with a headquarters section, a treatment squad (two treatment teams), an ambulance squad, and a combat medic section. The following duties apply to all medical platoon formations. The next higher leader is responsible for ensuring subordinates successfully execute their duties.

BATTALION SURGEON

1-53. The battalion surgeon/medical officer is a member of the commander's personal and special staff. The battalion surgeon also serves as the medical advisor to the battalion commander and the staff. In this role, the battalion surgeon advises the battalion commander on the employment of the medical platoon and on the health of the battalion. This officer is responsible for all medical treatment provided by the platoon. The battalion surgeon is also the supervising physician (medical officer/field surgeon) of the medical platoon's treatment squad. When the medical treatment squad splits, the battalion surgeon serves as the medical provider for treatment team "bravo". Their responsibilities include—

- Advising the commander on the health of the battalion.
- Providing current information on the battalion AHS support plan/medical common operational picture (MEDCOP) to surgeons of the next higher and adjacent headquarters to maintain medical situational awareness.
- Advising the battalion commander and his or her staff on AHS support operations and the health threat.
- Advising the commander on the effects of the Geneva Conventions on AHS support.
- Planning and directing Role 1 AHS support for the battalion.
- Serving as the Battalion Surgeon (Field Surgeon) and treatment team bravo provider.
- Serving as the medical platoon leader, as required.
- Supervising the health, welfare, organizational training, administration, discipline, and maintenance of equipment, supply functions, and employment of assigned or attached personnel.
- Supervising and overseeing all medical treatment provided by platoon personnel.
- Examining, diagnosing, treating, and prescribing courses of treatment for patients, to include DNBI, TCCC, and trauma management.
- Monitoring the holistic health and fitness (H2F) program of the battalion according to FM 7-22.
- Supervising the battalion COSC program to include training troop leaders in the preventive aspect of stress on Soldiers.
- Supporting humanitarian assistance programs, when directed.
- Providing operational public health support for the battalion.
- Requesting operational public health support from the brigade for requirements beyond their (battalion surgeon) capabilities.
- Planning and overseeing operational public health training for battalion personnel.
- Monitoring the command operational public health program to include health risk assessment and medical surveillance.
- Planning for operational dental care and appropriate level of dental support.
- Coordinating with the supporting veterinary element for subsistence, animal care, and animal disease surveillance.
- Overseeing and/or conducts the medical Army warrior task training, continuing medical education, and clinical training of subordinate medical platoon personnel.
- Overseeing the training of CLSs, aid and litter teams, and unit field sanitation teams.
- Ensuring that field health records are maintained.
- Coordinating and monitors patient decontamination operations to include:
 - Layout and establishment of patient decontamination site (PDS).

- Use of collective protection.
- Training of nonmedical personnel for patient decontamination teams.
- Using nonmedical Soldiers to perform patient decontamination procedures under medical supervision.

MEDICAL OPERATIONS OFFICER

1-54. According to the Table of Organization and Equipment (TOE) the medical operations officer (MEDO) is the operations/readiness officer for the platoon. They plan, coordinate, and execute the AHS support for the battalion. Generally the MEDO fills the medical platoon leader's role. The TOE also depicts the battalion surgeon as the medical platoon leader. Due to the many responsibilities of the battalion surgeon being a member of both the commander's personal and special staff, the battalion's field surgeon, and the provider for treatment team bravo, the MEDO generally carries out all of the duties and responsibilities of the medical platoon leader. The MEDO works with the battalion surgeon and physician assistant (PA) to ensure medical treatment and AHS support requirements are met for the battalion. This officer is the primary leader for medical platoon operations, administration, training, and logistics and assists the battalion surgeon in planning and directing Role 1 care for the battalion. As it pertains to medical training in a deployed environment, the MEDO ensures time is allocated for training (METT-TC dependent) and assists in setting it up. The field surgeon and/or PA dictate what is to be trained.

Note. The remainder of this publication will discuss the roles and responsibilities of the leadership within medical platoons. When describing the responsibilities of the platoon leader, it will be referring to the Medical Service Corps officer. When describing the responsibilities of the physician, it will designate them as the battalion surgeon, field surgeon, doctor, or physician.

1-55. The medical platoon leader develops trust and understanding with the battalion and company commanders and staff. Through medical command and control the medical platoon leader synchronizes the execution of the other 9 medical functions for the battalion. The entire platoon must execute disciplined initiative consistent with the commander's medical guidance and train subordinates to do the same.

1-56. The platoon leader is responsible for what the platoon does or fails to do, including tactical employment, training, administration, personnel management, and logistics. Successful platoon leaders handle this responsibility by planning, making timely decisions, issuing orders, assigning tasks, and supervising platoon activities.

1-57. The medical platoon leader coordinates, synchronizes, and assists the battalion surgeon in monitoring the battalion H2F program according to FM 7-22. They ensure all assigned personnel are trained in the principles, elements, and domains of H2F.

1-58. Medical platoon leaders fully understand the capabilities and limitations of their personnel, both assigned and attached, and all issued vehicles and equipment. They conduct MDMP with the battalion staff and develop and adhere to timelines using

reverse planning from latest time information is of value (LTIOV), and understand the commander's intent and that of the commander two levels up, allowing them to exercise disciplined initiative to accomplish the mission in the absence of orders. Platoon leaders ensure key tasks and information requirements are understood by all subordinates. They backbrief the commander on their plan to accomplish the mission and allot time for squad and team leaders (TL) to plan. They evaluate how to provide AHS support to the battalion at the platoon level, template this support plan down to the squad and team, and continually plan and reassess one phase ahead during execution. They plan communications to enable early and accurate warning through timely and accurate reporting, maneuver their elements, and employ the BAS and other medical attachments. They conduct rehearsals to ensure all team members understand the plan and to identify any planning shortfalls.

1-59. During planning, platoon leaders use parallel planning to issue operation orders (OPORD), fragmentary orders (FRAGORD), and warning orders (WARNORD). The platoon leader works with the battalion staff to develop the battalion's AHS support plan.

1-60. The medical platoon leader directs and assists the medical platoon sergeant (PSG) in planning and executing sustainment. They conduct planning with the help of the leaders and attachments within the platoon and develop redundant (digital and analog) graphic control measures for distribution. Platoon leaders conduct TLP and identify the need for enablers and assets, synchronize them, and request them in a timely manner. They assist supported companies in selecting locations for CCPs. They coordinate with adjacent units and understand that unit's mission. Prior to execution, they perform precombat inspections (PCI) according to the platoon SOP.

1-61. During execution, medical platoon leaders position themselves where they can influence the most critical tasks of the mission while controlling the medical operations and logistics of the platoon. They use standardized report formats to keep the commander and maneuver sections informed. They provide guidance to the squad and TLs to help accomplish the mission. Additionally, they collect section range cards and prepare a platoon sector sketch. They direct the development and refinement of the platoon's preexecution tasks and make adjustments when required. For more information on leadership see ADP 6-22. Their responsibilities include—

- Providing current information on the battalion AHS support plan/medical common operational picture (MEDCOP) to medical operations staffs of the next higher and adjacent headquarters to maintain medical situational awareness.
- Advising the battalion commander and their staff on AHS support operations and if the battalion surgeon is not available the health threat.
- Advising the battalion commander on the effects of the Geneva Conventions on AHS support.
- Planning and directing Role 1 AHS support for the battalion.
- Serving as the medical platoon leader, as required.

- Supervising the health, welfare, organizational training, administration, discipline, and maintenance of equipment, supply functions, and employment of assigned or attached personnel.
- Planning medical evacuation (ground and air).
- Coordinating medical logistics (class VIII, medical supplies, blood management, and field level and sustainment support medical maintenance).
- Requesting Class VIII resupply through the battalion logistics staff.
- Supporting humanitarian assistance programs, when directed.
- Requesting operational public health support from the brigade for requirements beyond their (battalion surgeon) capabilities.
- Planning for operational dental care and appropriate level of dental support.
- Coordinating with the supporting veterinary element for subsistence, animal care, and animal disease surveillance.
- Planning medical Army warrior task training, continuing medical education, and clinical training of subordinate medical platoon personnel.
- Planning the training of CLSs, aid and litter teams, patient decontamination augmentees, unit field sanitation teams, and operational public health training for battalion personnel.
- Coordinating patient decontamination operations.

MEDICAL PLATOON SERGEANT

1-62. The medical PSG is the senior most experienced medic in the battalion and the only NCO that assumes a leadership role from a commissioned officer, the PSG provides expertise, helps, and advises the platoon leader. They lead the platoon in the platoon leader's absence, and supervise the platoon's administration, logistics, and maintenance. The PSG assists the platoon leader with the development of paragraph four of the OPORD. PSGs understand the commander's intent and that of the commander two levels up.

1-63. The PSG assists the medical platoon leader and supervises the operations of the platoon. The PSG plans and supervises the maintenance of platoon vehicles and equipment. The PSG ensures enlisted personnel are certified in their MOS medical training. The PSG serves as the ambulance section leader, supervising the activities and functions of the ambulance squad to include maintenance of ambulances and associated equipment. The PSG is responsible for the training of the Soldiers of the medical platoon and provides training and supervision of operational security procedures. They also aids in the aid and litter teams mission and coordinates with the unit ISGs and other supported elements to determine medical support in concert with approved medical support plans. The PSG prepares reports of platoon activities and functions with the appropriate officer, the medical platoon leader, or the battalion surgeon.

1-64. The PSGs primary focus is directing all resupply and maintenance activities. Requests for both general categories of supplies and Class VIII supplies fall under the purview of the medical PSG. This includes supply economy procedures, advice on supply economy procedures, and maintenance of authorized stockage levels, also known

as ASL, of expendable supplies. The PSG uses, or directs the use of, the Defense Medical Logistics Standard Support (also referred to as DMLSS) Customer Assistance Module (DCAM) application for routine requisitions; however, the requests to fill the supporting brigade medical supply office (BMSO) are accomplished by any means available. The PSG receives requests from the section leader for rations, water, ammunition, and replacement equipment, and conducts coordination directly with the unit first sergeant (1SG), or executive officer (XO) using standardized report formats for all classes of supply. They develop the scheme of support overlay and distribute it across the platoon.

1-65. The PSG assists the medical platoon leader in coordinating, monitoring, and training the battalion H2F program according to FM 7-22.

1-66. Additionally, the PSG maintains platoon status of personnel, weapons, and equipment and submits standardized reports to the commander or 1SG. They ensure that ammunition, supplies (including Class VIII), and loads are evenly distributed.

1-67. They monitor the morale, discipline, and health of the platoon and ensure that the platoon adheres to the platoon leader's timeline. The PSG enforces compliance with units SOPs.

1-68. The PSG conducts precombat checks (PCC) and is responsible for the security plan during all operations. They recommend and confirm locations of CCPs, ambulance exchange points (AXP), logistics release points (LRP), and maintenance collection points (MCP), and template them on the scheme of support overlay. The PSG delegate's responsibility to squad and team leaders to confirm or deny suitability of all CCPs/AXPs/LRPs/MCPs) that are templated on the scheme of support overlay. The PSG enforces net discipline amongst the platoon, and distributes priorities of work during all phases of operations.

Note: It is recommended that both the medical operation officer serving as the platoon leader and the platoon sergeant review this publication and CALL Handbook 18-24 prior to assuming duties.

SECTION LEADER

1-69. The term section leader is used to denote that the field surgeon, PA, PSG or squad leader (SQDLDR) is in charge of a specific task organization (TASKORG). For example, when the BAS is executing extended medical support operations it splits into two treatment teams. By adding the augmented ambulances from the BSMC the teams become medical sections. The section leader is responsible for the tactical employment and combat readiness of their section, including the health, welfare, and training of Soldiers and the maintenance of weapons and equipment of the section. They assist the platoon leader plan the scheme of maneuver and make relevant recommendations during planning and execution.

1-70. The section leader maintains section status of personnel, weapons, and equipment and submits standardized reports to the platoon leader or PSG. They ensure that

ammunition, supplies, and loads are evenly distributed in the section. Section leaders direct the maintenance of the section's weapons and equipment and perform PCCs.

1-71. The section leaders delegate tasks to squad and TLs, and supervise their accomplishment. While maneuvering their section during execution, within the platoon leader's guidance, the section leader will refine the plan to meet the needs of a changing OE.

1-72. Additionally, the section leader should understand key tasks and information collection requirements and employ their section to accomplish them.

FIELD SURGEON

1-73. The field surgeon is the senior physician assigned and is responsible for the clinical operations of the BAS. The field surgeon also operates as the battalion surgeon; is the medical provider for treatment team "bravo", and when command directed, the medical platoon leader (see paragraph 1-43 for the duties of the field surgeon).

PHYSICIAN ASSISTANT

1-74. The PA performs general technical health care and administrative duties. The PA is advanced medical treatment qualified and works under the clinical supervision of a medical officer. When the medical treatment squad is performing extended medical support operations, they serve as the clinical professional for treatment team alpha. The PA's responsibilities include:

- Assisting in the planning and directing of Role 1 care for the battalion.
- Advising, in the absence of the battalion surgeon, the battalion commander and their staff on the status of the health of the command to include health threats and the effects of the Geneva Conventions on AHS support operations.
- Establishing and operating the BAS.
- Establishing and conducting treatment team operations when deployed in extended medical support operations.
- Assisting in the supervision and oversight all medical treatment provided by platoon personnel.
- Examining, diagnosing, treating, and prescribing courses of treatment within their scope of practice and abilities for DNBI and wounded patients, referring those patients requiring treatment beyond the PA's capability to the supervising physician or to a higher role of care.
- Planning, conducting and or supervising, with guidance from the medical platoon leader and battalion surgeon, the medical training of all battalion personnel including:
 - Continuing medical education and clinical training of subordinate medical platoon personnel.
 - Training of battalion medical platoon personnel in TCCC principles and procedures.

- Training and support for the biannual recertification of the MOS 68W medical platoon personnel in accordance with TC 8-800.
- Training Soldiers and leaders on the prevention of negative combat and operational stress reaction (COSR) and other stress-related reactions.
- Training of nonmedical personnel for patient decontamination teams.
- Training CLS.
- Training of aid and litter teams.
- Training of field sanitation teams.
- Training of battalion personnel in personal hygiene.
- Training of holistic health and fitness principles, elements, and domains for medical and nonmedical personnel according to according to FM 7-22.
- Conducting the battalion behavioral health (BH) program, to include training troop leaders in the preventive aspect of stress on Soldiers (with guidance from the battalion surgeon and/or medical platoon leader).
- Ensuring field medical records and/or electronic medical records (if available) are maintained on each Soldier at the BAS according to AR 40-66.

Note. In the absence of a battalion surgeon, the PA assumes the clinical leadership roles and responsibilities of the battalion surgeon.

MEDICAL TREATMENT SQUAD LEADER

1-75. The treatment SQDLDR assists the field surgeon and PA in the management of the BAS and performs administrative duties for the platoon. They provide emergency medical treatment (EMT) lifesaving steps congruent with MOS training or those tasks taught by the field surgeon.

1-76. The treatment SQDLDR is responsible for the combat readiness and tactical employment of the BAS. They supervise the health, welfare, and training of Soldiers, and maintenance of the vehicle, equipment, and weapons. They also ensure the squad implements H2F principals, elements, and domains according to FM 7-22.

1-77. The treatment SQDLDR maintains the squad's status of personnel, weapons, and equipment, and submit standardized reports to the PSG. They ensure that ammunition, supplies, and loads are evenly distributed, and direct the maintenance of the squad's weapons and equipment. Additionally, they inspect their Soldiers, their weapons, and their equipment.

1-78. The treatment SQDLDR helps the medical platoon leader and PSG plan the battalions AHS support plan. They delegate tasks to team leaders (known as TLs) and subordinates, and supervise their accomplishment. The SQDLDRs follow the platoon leader's plan and make recommendations, understand key tasks and information collection requirements and employ their squad to accomplish them. They plan for all aspects of establishing the BAS and keep the platoon leader and PSG informed on the treatment squads supply and equipment readiness.

1-79. The SQDLDR assumes the responsibilities of medical treatment team bravo when conducting extended medical coverage and medical section leader when evacuation assets are attached to the treatment team.

MEDICAL TEAM LEADER

1-80. Serves as the medical TL for a medical treatment team when the BAS is conducting extended medical coverage and treatment section leader when evacuation assets are attached to the treatment team.

1-81. The medical TL assists the field surgeon, PA, or treatment SQDLDR by providing direct oversight and supervision of assigned medics. The medical TL is the first link in the chain of command and is responsible for the combat readiness and tactical employment of the team, the health, welfare, and training of Soldiers, and the maintenance of equipment and weapons. This includes implementing the H2F principles, elements, and domains according to FM 7-22.

1-82. The medical TL interprets the medical platoon leadership's intent and AHS support plan guidance into directed actions for Soldiers. The medical TL informs the medical platoon leadership of preparation status by personally checking on—medic's readiness of equipment such as vehicle fluid levels, medical equipment status, and packing lists according to the tactical standard operating procedures (TACSOP). Additionally, the medical TL verifies sensitive items and ammunition status, checking weapons and ammunition, and prepares the team for PCCs and PCIs.

1-83. The medical TL delegates tasks to subordinates and supervises the subordinate actions. They inform and provide recommendations to the medical platoon leadership. They establish the medical team for operations when conducting extended medical support operations.

EMERGENCY CARE SERGEANT

1-84. The emergency care sergeant assumes control of the vehicle in the absence of the ambulance/aide driver. They assist in navigating and maneuvering the vehicle. The emergency care sergeant employs vehicles/weapons/optics to accomplish the tasks and requirements, delegate tasks to the driver, and supervise their accomplishments. The emergency care sergeant also ensures ambulance teams are implementing the H2F principles, elements, and domains according to FM 7-22. Other duties of the emergency care sergeant include:

- Serves as the ambulance vehicle commander.
- Performs triage and EMT procedures in the care and management of trauma patients.
- Prepares patient for movement.
- Provides patient care en route.
- Maintains contact with supported units.
- Collects patients.
- Performs CBRN detection procedures.

AMBULANCE AND AIDE DRIVER

1-85. The ambulance/aide driver is responsible for the combat readiness and tactical employment of their vehicle. The driver tactically maneuvers the vehicle as directed by the vehicle commander.

1-86. Drivers perform the preventive maintenance and operator checks of the vehicle and equipment. They maintain vehicle status of personnel, weapons, equipment, and petroleum, oils, and lubricants, and submit reports to the emergency care sergeant.

1-87. Drivers recognizes the slope of the terrain and repositions the vehicle to ensure it remains under cover and concealment. The driver assumes control of the vehicle in the absence of the crew and assist in navigating and maneuvering the vehicle. The driver is always looking for the next covered and concealed position during maneuvering and communicates it to the vehicle commander.

1-88. They assist the ambulance team in maintaining and employing all communication and navigations system mounted in the vehicle. They also are responsible for maintaining a message/evacuation log.

1-89. They perform PCCs ensuring that supplies and loads are evenly distributed and secured in the vehicle.

1-90. They receive a five-point contingency plan when personnel leave the vehicle. They observe their sector of responsibility, camouflage the vehicle, and provide local security when needed. They are also responsible for ensuring they abide by the principles, elements and domains of H2F according to FM 7-22.

EMERGENCY CARE SERGEANT (SENIOR MEDIC)

1-91. The company senior medic normally collocates with the 1SG. When the company is engaged, they remains with the 1SG and provides medical advice, as necessary. As the tactical situation allows, they will provide medical treatment and prepare patients for MEDEVAC. The senior medic takes control of and works in coordination with the ambulance team supporting the company. The company senior medic normally remains with the company command post, but may be used anywhere in the company, assisting the ambulance teams in some situations. Functions of company senior medic include:

- Oversees the platoon combat medics.
- Performs company-level triage and TCCC for the sick and wounded under the control of the company 1SG.
- Assists unit leadership in selecting sites for CCPs.
- Arranges company-level MEDEVAC for litter patients and directs ambulatory patients to CCP or to the BAS.
- Initiates a DD Form 1380, (*Tactical Combat Casualty Care (TCCC) Card*) for the sick and wounded and, as time permits, prepares a DD Form 1380 on deceased personnel.
- Screens, evaluates, and treats, within their capabilities, those patients suffering minor illnesses and injuries.

- Provides company-level guidance on the implementation of the H2F principles, elements, and domains according to FM 7-22.
- Keeps the company commander, ISG, and the battalion surgeon/medical platoon leader informed on matters pertaining to the health and welfare of the Soldiers.
- Manages company-level Class VIII resupply for the combat medics and unit CLS.
- Maintains sufficient quantities of medical supplies to support the tactical situation.
- Serves as a member of the unit field sanitation team. In this capacity they advise the commander and supervise unit personnel on matters of personal hygiene and field sanitation (See ATP 4-25.12 and TC 4-02.3).

COMBAT MEDIC

1-92. To foster good interpersonal relations and morale of combat troops, every effort should be made to attach the same combat medic to the same unit they habitually supports each time the unit deploys. However METT-TC dependent, during lulls in combat operations they should return to the medical platoon for consultation and proficiency training. Functions of combat medic are as follows:

- Assists the maneuver PSG in directing aid and litter teams and serves as the medical advisor to the maneuver platoon leader.
- Provides technical expertise and supervision of the platoon's CLS and assists the PSG in CLS bag inventories.
- Performs platoon-level triage and TCCC for the sick and wounded under the control of the maneuver PSG.
- Arranges platoon-level MEDEVAC for litter patients and directs ambulatory patients to CCP or to the BAS.
- Initiates a DD Form 1380 for the sick and wounded and, as time permits, prepares a DD Form 1380 on deceased personnel.
- Screens, evaluates, and treats, within their capabilities, those patients suffering minor illnesses and injuries.
- Provides platoon-level guidance on the implementation of H2F principles, elements, and domains according to FM 7-22.
- Aids the maneuver platoon leader/PSG in field hygiene matters and checks the health, welfare, and physical condition of platoon members.
- Manages platoon-level Class VIII resupply for the CLS.
- Maintains sufficient quantities of medical supplies to support the tactical situation.

COMBAT LIFESAVER

1-93. A *combat lifesaver* is a nonmedical Soldier trained to provide enhanced first aid as a secondary mission. Normally, one member of each squad, team, or crew is trained (FM 4-02). The CLS provides emergency care as a secondary mission as their primary (combat) mission allows. The CLS does not replace the combat medic, however they

should assist the combat medic in providing far forward care and in preparing casualties for evacuation. For information on training CLS refer to appendix E.

AID AND LITTER TEAM

1-94. Aid and litter teams are identified as special teams at the squad, platoon and company levels. They must be trained and identified as special teams in SOPs and planning. They free medical platoon personnel from nontreatment duties to perform rescue operations and movement of casualties for both CASEVAC and MEDEVAC. Minimal patients make excellent aid and litter teams. Minimal patients by definition only require limited treatment and can be returned to duty immediately. These Soldiers are often able-bodied and can be put to good use by medical platoon personnel.

SECTION IV – MEDICAL PLATOON TASK ORGANIZATION

1-95. This section describes different types of medical platoon TASKORGs. For more information on TASKORG and equipment refer to the force management system website.

Note. The cavalry squadron's medical platoon is similarly configured and employed as the infantry brigade combat team (IBCT), armored brigade combat team (ABCT), and Stryker brigade combat team (SBCT), with some variation.

1-96. The ABCT, is task-organized into two types of battalions: the combined arms battalion (CAB) (Infantry) and the CAB, (Armored). Both types of battalion utilize tracked vehicles for treatment and evacuation but have slight differences in assigned personnel due to the amount of infantry companies assigned. Discussed below are the TASKORGs for these battalions.

COMBINED ARMS BATTALION (INFANTRY)

1-97. The CAB (Infantry) medical platoon is organic to the HHC. The platoon is organized with a medical treatment platoon headquarters, a medical treatment squad consisting of two treatment teams, an ambulance squad (tracked), and a combat medic section. The medical platoon is organized as shown in figure 1-4 on page 1-32.

1-98. The CAB (Infantry) has two mounted infantry companies and one tank company assigned. Even though it is infantry heavy, it utilizes a tracked vehicle variant of the armored multi-purpose vehicle-medical evacuation (AMPV-ME) or M113 as the MEDEVAC vehicle. The AMPV-ME/M113 is used to treat and transport patients while protecting them in a variety of environments and terrains.

1-99. The CAB (Infantry) combat medic section has a total of nine personnel assigned. Generally, the section is attached as follows:

- One emergency care sergeant and three combat medics to each infantry rifle company.
- One combat medic to the scout platoon.

1-100. The CAB (Infantry) ambulance squad has a total of 18 personnel assigned with six ambulances. Generally, the squad attaches an ambulance team to each tank platoon.

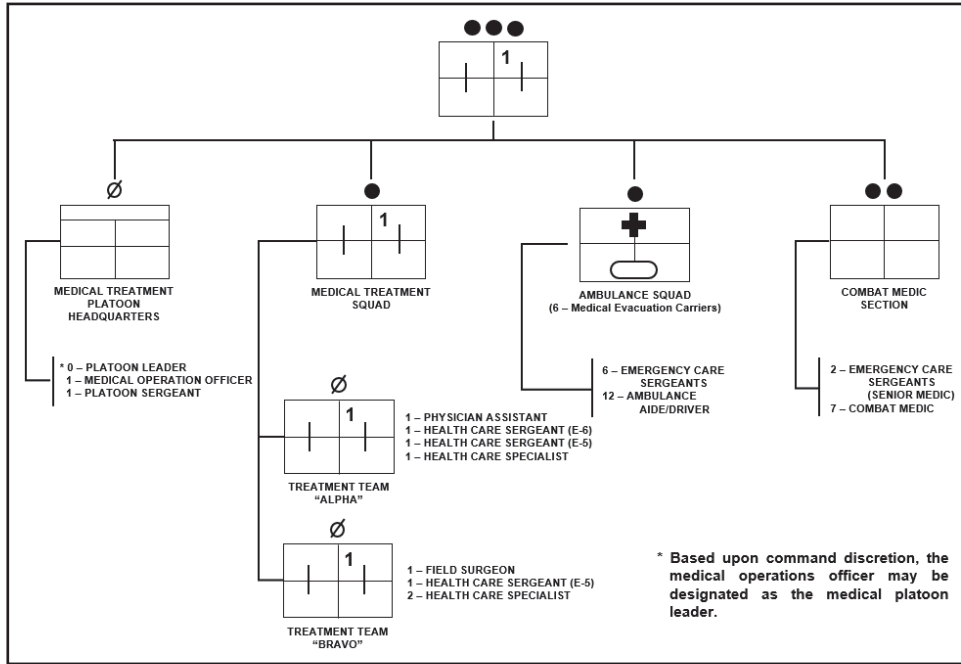

Figure 1-4. Combined arms battalion (infantry) medical platoon

COMBINED ARMS BATTALION (ARMORED)

1-101. The CAB (Armored) medical platoon is organic to the HHC. The platoon is organized with a medical treatment platoon headquarters, a medical treatment squad consisting of two treatment teams, an ambulance squad (tracked), and a combat medic section. The medical platoon is organized as shown in figure 1-5.

1-102. The CAB (Armored) has one mounted infantry company and two tank companies assigned. This medical platoon also utilizes a tracked vehicle variant of the AMPV-ME or M113 as the MEDEVAC vehicle. The AMPV-ME/M113A3 is used to treat and transport casualties while protecting them in a variety of environments and terrains.

1-103. The CAB (Armored) combat medic section has a total of seven personnel assigned. Generally, the section is attached as follows:

- One emergency care sergeant and three combat medics (one per rifle platoon) to each infantry rifle company.
- One combat medic to the HHC.
- One combat medic to the scout platoon.
- One combat medic to the mortar platoon.

1-104. The CAB (Armored) ambulance squad has a total of 18 personnel assigned with six ambulances. Generally, the squad attaches an ambulance team to each tank company.

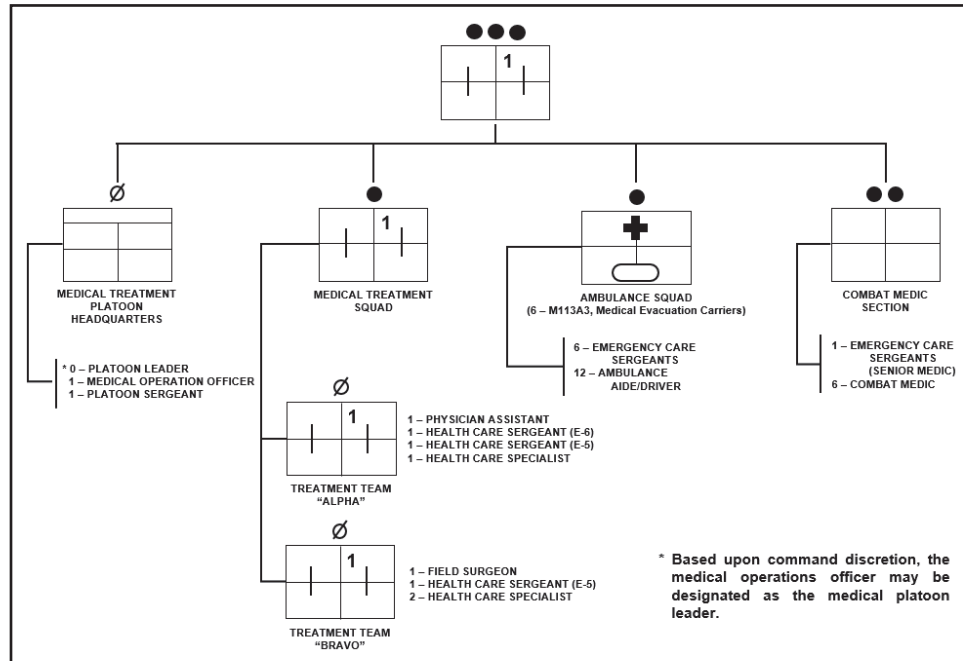

Figure 1-5. Combined arms battalion (armored) medical platoon

INFANTRY BATTALION MEDICAL PLATOON

1-105. The infantry battalion medical platoon is organic to the HHC. The platoon is organized with a medical platoon headquarters, a medical treatment squad consisting of two treatment teams, an ambulance squad (wheeled), and a combat medic section. The medical platoon is organized as shown in figure 1-6 on page 1-34.

1-106. The infantry battalion has three infantry companies and a weapons company assigned. This medical platoon utilizes the M997A2 ambulance. It is equipped with basic armor and used to transport patients from the battlefield to BAS.

1-107. The infantry battalion combat medic section has a total of 15 personnel assigned. Generally, the section is attached as follows:

- One emergency care sergeant and three combat medics (one per rifle platoon) to each infantry rifle company.
- One combat medic to the HHC.
- One combat medic to the scout platoon.
- One combat medic to the mortar platoon.

1-108. The infantry battalion ambulance squad has a total of 24 personnel assigned with eight ambulances. Generally, the squad attaches an ambulance team to the weapons company.

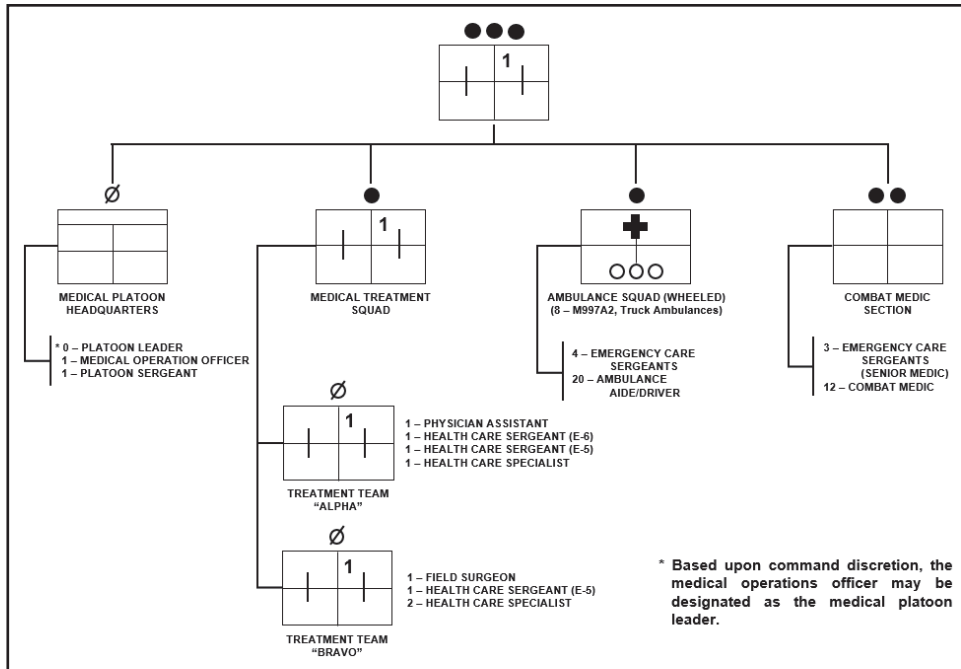

Figure 1-6. Infantry battalion medical platoon

AIRBORNE INFANTRY BATTALION MEDICAL PLATOON

1-109. The airborne infantry battalion medical platoon is organic to the HHC. The platoon is organized with a medical platoon headquarters, a medical treatment squad consisting of two treatment teams, an ambulance squad (wheeled), and a combat medic section. The medical platoon is organized as shown in figure 1-7.

1-110. The airborne infantry battalion has three airborne infantry companies and a weapons company assigned. This medical platoon utilizes the M997A2 ambulance. It is equipped with basic armor and used to transport casualties from the battlefield to BAS.

1-111. The airborne infantry battalion combat medic section has a total of 15 personnel assigned. Generally, the section is attached as follows:

- One emergency care sergeant and three combat medics (one per rifle platoon) to each infantry rifle company.
- One combat medic to the HHC.
- One combat medic to the scout platoon.

- One combat medic to the mortar platoon.

1-112. The airborne infantry battalion ambulance squad has a total of 24 personnel assigned. Generally, the squad attaches an ambulance team to the weapons company.

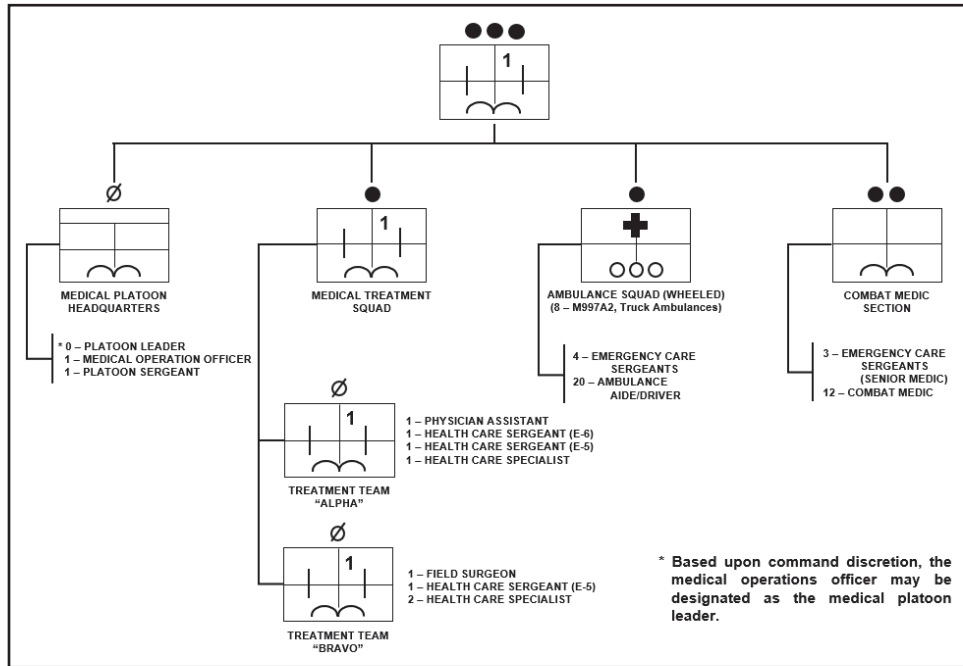

Figure 1-7. Airborne infantry battalion medical platoon

STRYKER BATTALION MEDICAL PLATOON

1-113. The Stryker battalion medical platoon is organic to the HHC. The platoon is organized with a medical platoon headquarters, a medical treatment squad consisting of two treatment teams, a MEDEVAC squad, and a combat medic section. The medical platoon is organized as shown in figure 1-8 on page 1-36.

1-114. The Stryker battalion utilizes the M1254A1 MEDEVAC vehicle, double V hull A1 (MEVVA1). It is a wheeled Stryker variant used for MEDEVAC. The MEVVA1 has a double hull for increased protection and survivability.

1-115. The Stryker battalion combat medic section has a total of 14 personnel assigned. Generally, the section is attached as follows:

- One emergency care sergeant and three combat medics (one per rifle platoon) to each infantry rifle company.
- One combat medic to the scout platoon.
- One combat medic to the mortar platoon.

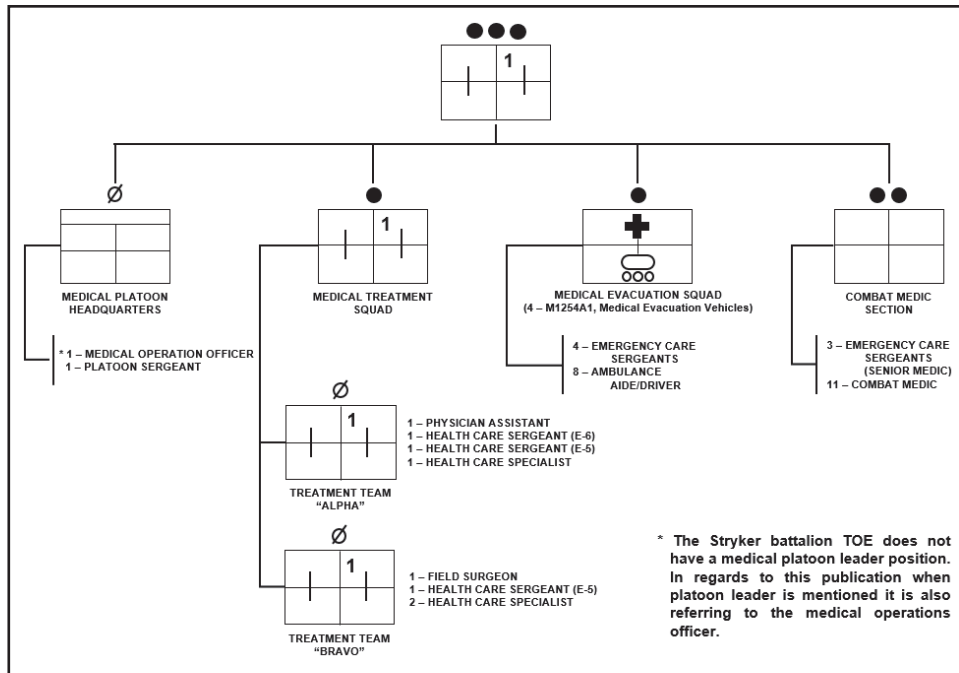

Figure 1-8. Stryker battalion medical platoon

Note. Separate and in addition to the BAS, the SBCT cavalry antiarmor troop is assigned a combat medic section with one emergency care sergeant and three combat medics.

SECTION V – EMPLOYMENT OF THE MEDICAL PLATOON

1-116. This section describes medical platoon employment.

MEDICAL PLATOON HEADQUARTERS

1-117. The headquarters section, under the direction of the platoon leader, provides for the command and control (C2) and resupply of the platoon. The platoon headquarters is manned by the platoon leader (MEDO), the medical PSG, and any other elements that may be attached, under operational control of or in a supporting role such as a treatment team or an ambulance section from the BSMC. It normally collocates with the treatment squad to form the BAS. The command post includes the AHS support planning and operations functions performed by the platoon leader. The platoon has access to the battalion wire communication network for communications with all major elements of the battalion and with other supporting units. Wireless communications for this section consist of a tactical frequency modulation (FM) radio mounted in the platoon headquarters vehicle. The medical platoon employs an FM radio network for AHS

support. The medical platoon headquarters serves as the net control station for the platoon.

MEDICAL TREATMENT SQUAD

1-118. The medical treatment squad is the basic medical treatment element of the BAS. It provides routine sick call services, triage, emergency medical care, and advanced medical treatment. This squad is staffed with a field surgeon, a PA, one health care SGT (E-6), two health care SGT (E-5), and three health care specialists (E-4 or E-3). The squad's field surgeon, PA, and enlisted health care personnel are all trained in medical treatment procedures, commensurate with their positions and skill levels.

1-119. The treatment squad can split into two treatment teams (treatment team "alpha" and treatment team "bravo"). When augmented with two ambulance teams from the BSMC they operate as part of two separate medical sections (Medical Section A [MED SEC A] and Medical Section B [MED SEC B]), normally not to exceed 24 hours in support of the battalion. When split, the teams can operate in bounding medical support, when BAS must move to a new location, or extended medical support operations. In bounding medical support, one team remains at the current location and continues to treat patients, while the other team moves to a new location. Once the jump team has established a treatment capability at the new location, the other team evacuates or returns to duty all patients, and then moves to the new location.

1-120. Each treatment team is staffed with a field surgeon or a PA, one or two health care SGTs (E-6 or E-5), and one or two health care specialists (E-4 or E-3). In continuous operations, when operating for longer periods, personnel efficiency and unit capability will tend to deteriorate. Each team employs treatment vehicle(s) with a medical equipment set (MES) tactical combat medical care. The treatment team "bravo" is responsible for maintaining the MES patient decontamination and chemical treatment, which provides enough supplies to decontaminate 60 patients exposed to CBRN agents/hazards and medical supplies required to treat 60 patients exposed to chemical agents/hazards.

1-121. For communications, each treatment team uses an FM tactical radio and is deployed in the medical platoon's operations net. However, under certain tactical conditions, the CTCP may require BAS elements to use the administrative and logistics (A/L) network.

1-122. The BAS is under the tactical control of the CTCP and is normally deployed in its vicinity. To reduce ambulance turnaround time in providing advanced medical treatment to patients within 30 minutes of wounding, the BAS may split and place its treatment teams as close to maneuvering companies as tactically feasible. The CTCP closely coordinates locations for forward positioning sustainment elements (including medical treatment elements) with the battalion operations officer. This ensures that the location of these elements is known by commanders of maneuvering forces. Coordination ensures that these elements are not placed in the way of friendly maneuvering forces, in the line of fire, or in areas subject to be overrun by rapidly advancing enemy forces. Treatment teams situated close to (within 1,000 meters [1.6

miles] of) maneuvering companies in contact must be prepared to withdraw to preplanned alternate positions on short notice.

1-123. When maneuvering, companies anticipate large numbers of casualties, augmentation of the medical platoon with one or more treatment teams from the BSMC should be made. Augmenting treatment teams remain under the tactical control of the CTCP but are under the operational control of the medical platoon leader. A suggested scheme of employment is to place a team in close support of each maneuvering company while locating one treatment team in the combat trains. The battalion aid station should not be placed near targets of opportunity, such as ammunition, petroleum, oils and lubricants, distribution points, or other targets that may be considered lucrative by the opposing force. Considerations for the location of the BAS should include:

- Tactical situation/commander's plan.
- Expected areas of high casualty density.
- Security.
- Protection afforded by defilade.
- Convergence of lines of drift.
- Evacuation time and distance.
- Accessible evacuation routes.
- Avoidance of likely target areas such as bridges, fording locations, road junctions, and firing positions.
- Solid ground with good drainage.
- Proximity to an open area suitable for helicopter landing.
- Available communication means.
- Additional space near this site for establishing a patient decontamination site if required.

1-124. At the BAS, patients requiring further evacuation to the rear are stabilized for movement. Constant efforts are made to prevent unnecessary evacuation; patients with minor wounds or illnesses are treated and return to duty (RTD) as soon as possible. Other functions of the BAS include:

- Providing treatment to include TCCC, advanced trauma management, and routine sick call (when time permits).
- Providing prolonged care if isolated, MASCAL elsewhere prevents displacing patients, evacuation assets are unavailable, or METT-TC.
- Receiving and recording patients.
- Notifying the battalion personnel staff of all patients processed through the BAS and giving identification and disposition of patients.
- Preparing DD Form 1380 (*Tactical Combat Casualty Care [TCCC] Card*), as required. See JP 4-02 and AR 40-66 for information on completion and disposition of the form.
- Verifying information contained on the DD Form 1380 of each patient evacuated to the BAS.
- Requesting and monitoring MEDEVAC of patients.

- Monitoring personnel, when necessary, for CBRN contamination prior to medical treatment.
- Supervising patient decontamination and treating CBRN patients (refer to ATP 4-02.7/MCRP 3-40A.6/NTTP 4-02.7/AFTTP 3-42.3, chapter 5, ATP 4-02.83, ATP 4-02.84, and ATP 4-02.85).

Note. Patient decontamination is performed by a pre-trained team. This team is composed of eight nonmedical personnel from supported units working under the supervision of medical platoon personnel. Patient decontamination teams perform best when they train and exercise their skills with the supporting BAS.

1-125. Medical evacuation from the BAS is performed by ground ambulances from the BSMC and by divisional air ambulances of the forward support MEDEVAC platoons.

1-126. Patient holding and food service is not available at the BAS. Therefore, only procedures necessary to preserve life or limb, or enable a patient to be moved safely, are normally performed at the BAS.

1-127. Ammunition and individual weapons belonging to patients evacuated from the BAS are handled as directed by unit's TACSOP or policy. All excess equipment collected at the BAS is disposed of by the battalion logistics staff or as directed by command SOP.

Note. Patients will always retain their protective mask when evacuated to the next echelon of care, as long as they are in the combat zone. Based on the threat, they may retain the protective mask until evacuated out of the theater of operations.

1-128. Patients requiring dental treatment are provided relief for dental pain, if required, then evacuated to the BSMC where operational dental care (emergency and essential dental treatment) is provided.

1-129. Patients requiring optometry services initially report to the BAS. For those patients requiring only routine replacement of spectacles, necessary information is obtained from the individual and forwarded to the BSMC. The required spectacles are fabricated and forwarded to the BAS for issue to the patient. For optometry services other than routine repair or replacement of spectacles, patients are transported to the closest optometry team, normally located in the corps or division support area.

ROLE 1 BATTALION AID STATION CONFIGURATIONS

1-130. Configuration is key to the effectiveness of a Role 1 BAS's ability to maximize patient flow, provide medical command and control, and survivability proportionate to their OE and surrounding threat levels. Configuration is not related to readiness level (red, amber, green), which describes the amount of equipment ready for immediate use.

1-131. Having a standardized and rehearsed configuration for the most common OE will greatly improve battalion medical processes and patient survivability. Each

configuration is custom to the resources and capabilities of the medical platoon executing them, but all configuration will maintain similar attributes despite differences in evacuation platforms and equipment for the unit, such as a Stryker versus an armored or infantry battalion. The medical platoon should build detailed TTPs in their TACSOP regarding BAS configurations. The following configurations are a way to organize resources and capabilities based on mission variables.

Tailgate Medical Support

1-132. *Tailgate medical support is an economy of force device employed primarily to retain maximum mobility during movement halts or to avoid the time and effort required to set up a formal, operational treatment facility (for example, during rapid advance and retrograde operations).* It is used for treatment on the move or short halts. In this configuration only the most critical equipment is set up, usually one table. It has an extremely rapid set up and tear down time, but is restrictive in complicated injury treatment and easily susceptible to MASCALs (see figure 1-9).

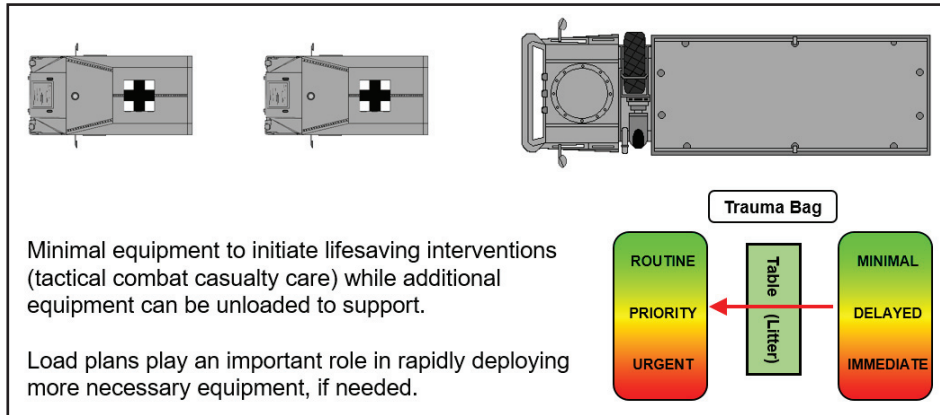

Figure 1-9. Example, battalion aid station configuration, tailgate medical support

Hasty Configuration

1-133. Used for short halts longer than a few hours or rapid maneuver operations. This configuration utilizes critical equipment and ancillary specialized equipment, but leaves sick call items loaded until needed. Usually has two or four tables depending on number of medical providers available. Quick set up and tear down. Great for Role 1 BAS survivability jumping when placed close to the FLOT or when enemy activity is likely requiring potential survivability jumps (see figure 1-10).

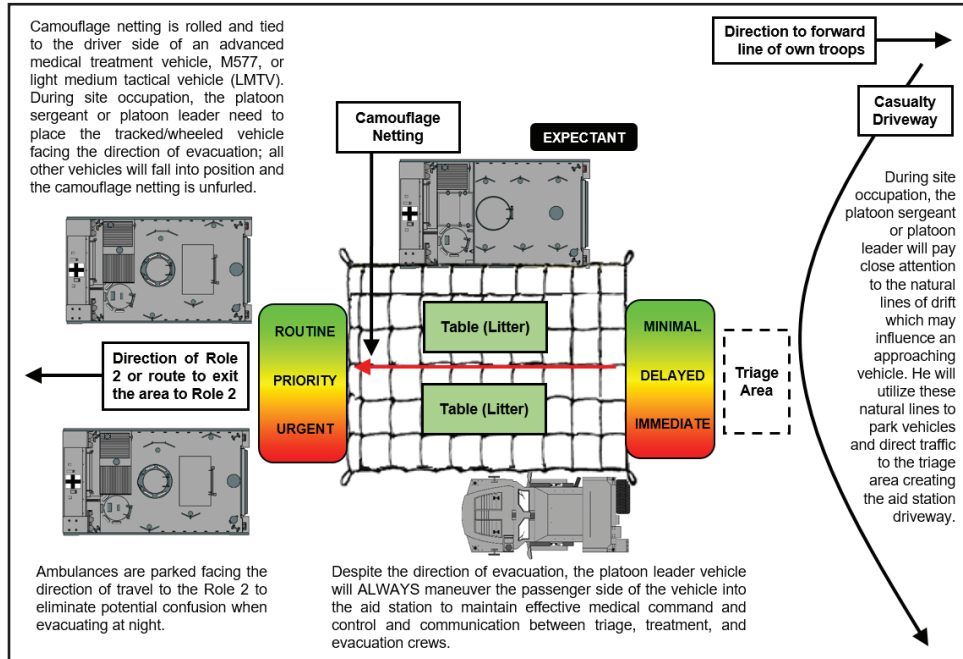

Figure 1-10. Example, battalion aid station configuration, hasty

Short-Term Configuration

1-134. Used for locations where medical support is relatively safe from enemy attack and movement of the Role 1 BAS is not expected for longer periods of time. Includes all equipment and tables. Usually includes a tent for the treatment area. Slower set up and tear down but allows cleaner, more comprehensive care and patient stabilization (see figure 1-11 on page 1-42).

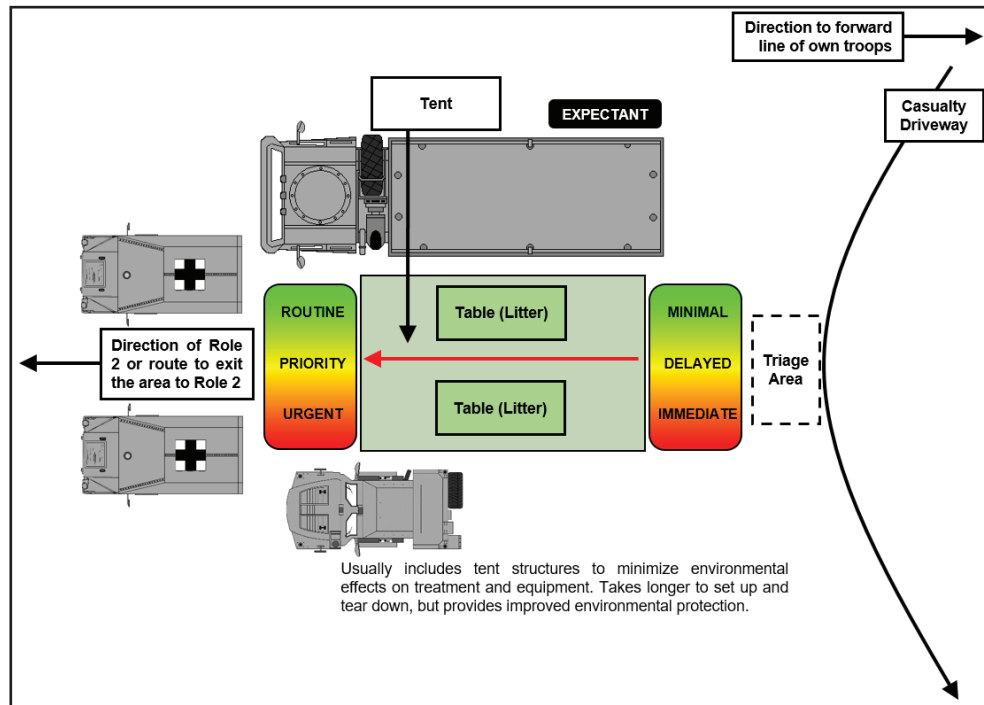

Figure 1-11. Example, battalion aid station configuration, short-term

Long-Term Configuration

1-135. Used for locations where medical support is relatively safe from enemy attack and Role 1 BAS is fixed. Includes set up of all equipment available. Usually includes tent or hardstand building and generator/air conditioning. Very slow to set up and tear down but provides most favorable environment for clean, comprehensive care and patient stabilization (see figure 1-12).

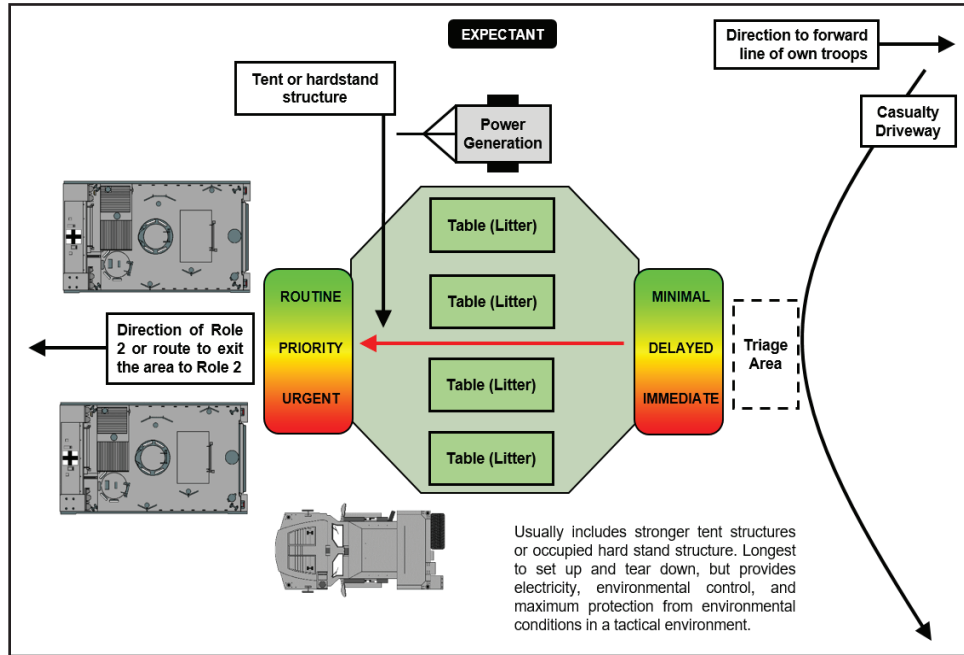

Figure 1-12. Example, battalion aid station configuration, long-term

SPLITTING THE BATTALION AID STATION

1-136. Splitting the Role 1 BAS into the medical section alpha (MED SEC [A]) and medical section bravo (MED SEC [B]) is a Role 1’s most misunderstood capability (see figure 1-13 on page 1-44). Splitting the BAS is a tactical decision based on the OE and METT-TC. Using MED SEC (A)/ MED SEC (B) in this way is equivalent to an infantry platoon conducting bounding Overwatch (refer to ATP 3-21.8). This technique should be used anytime the battalion is conducting a tactical movement where there is a known or likely threat, and the potential to receive battle injuries is elevated. Mission, enemy, terrain, troops available, time, and civilian considerations dictate the length of the bounds. However, the bounding MED SECs should never move beyond evacuation range of the halting MED SEC. When the lead element of the battalion is outside of the evacuation range of the halted MED SEC based on time/distance analysis, the bounding MED SEC will halt, set up a hasty aid station, and prepare to receive casualties. Once they are established, the halted MED SEC will collapse, package their equipment, and move forward becoming the bounding MED SEC. The destination of the bounding element is based on the suitability of the next location to provide cover/concealment of the next MED SEC. There are two very distinct methods for splitting the Role 1 that generates specific advantages when used properly. Extended medical support is the first and most intuitive method and bounding medical support is the second and most beneficial method.

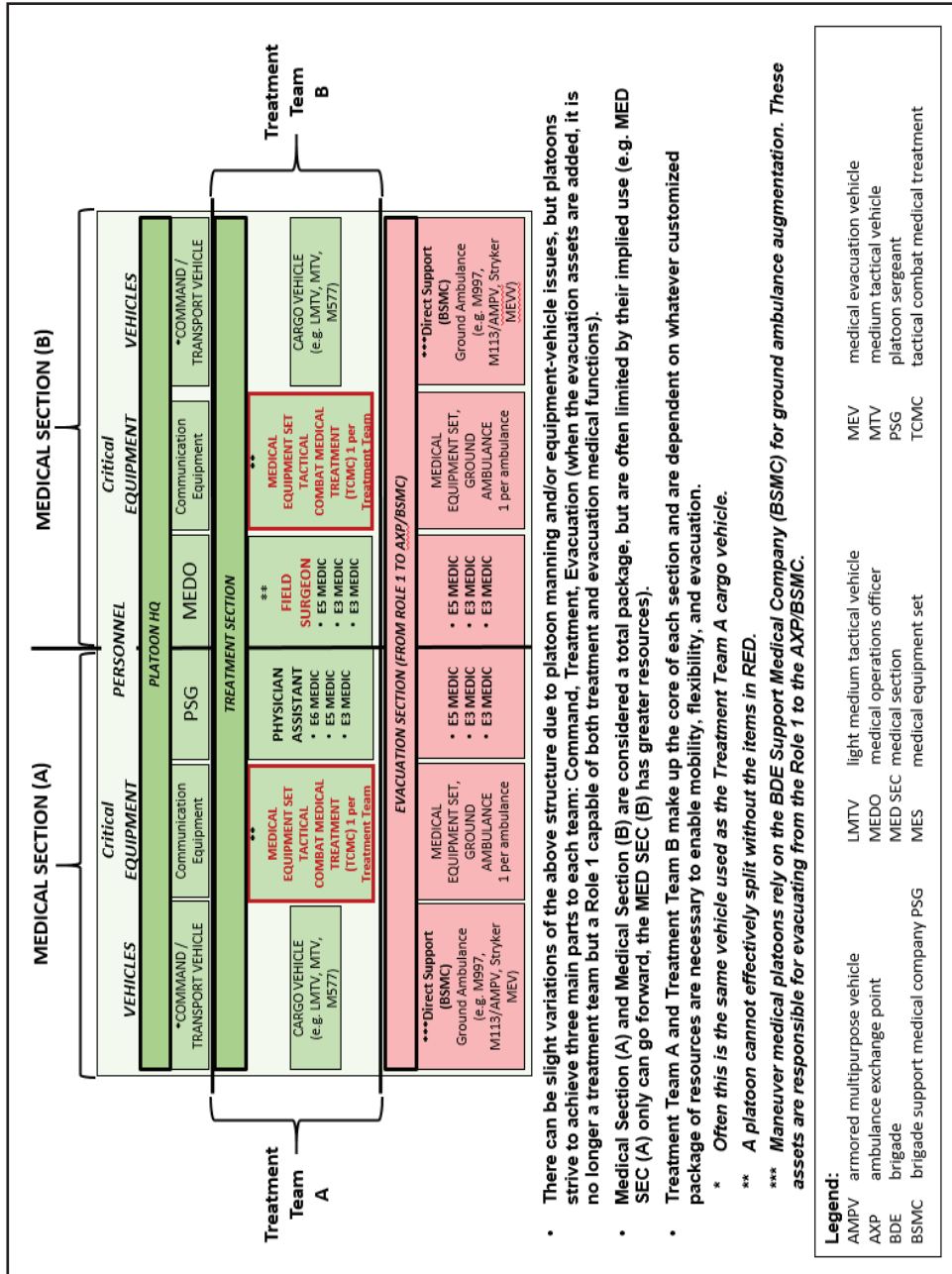

Figure 1-13. Extended medical support task organization

Extended Medical Support

1-137. The extended medical support method is useful when supported units spread further than a Role 1 BAS can support from a single location; however, the MED SEC (A) and/or MED SEC (B) has only half the capability to collect, stabilize, and evacuate the number of casualties of a consolidated BAS. Each section will have half the providers, the medics, the Class VIII, and the MEDEVAC platforms. Additionally, control over each section becomes more difficult when the BAS medical support's resources are spread out. To be successful, leaders at both medical sections must be able to communicate and make decisions independently when communication inevitably falters. The MED SEC (A) and MED SEC (B) can provide an extended reach of limited medical support, but over time mechanical or logistical issues will inevitably reduce one or both medical section's capabilities. Medical planners must consider the operations before committing to extended medical support (see figure 1-13). Some important planning factors when considering extended medical support are:

- How long are the operations requiring extended medical support expected to last?
- Where are the most casualties expected along the extended medical support area?
- What supplementary evacuation platforms are available?
- Where are the adjacent Role 1s, and can they support if called upon?
- How will C2 and patient regulation techniques be altered to accommodate dispersed medical assets and patient flow?

1-138. During planning, leveraging the full potential of a consolidated BAS should be considered before committing to extended medical support; however, if splitting is a capability that fits the needs of the mission, every effort should be made to reinforce resources within MED SEC (A) and MED SEC (B) and they should consolidate into the full medical treatment squad (BAS) as soon as possible.

Bounding Medical Support

1-139. One of the most valuable uses of MED SEC (A)/MED SEC (B) is the bounding medical coverage. As the Role 1 BAS receives and treats casualties from its initial rehearsed location and the conditions become set for their planned jump, the MED SEC (A) jumps first to the next site. The MED SEC (A) leaves the MED SEC (B) behind to clear casualties already received and/or receive any potential casualties as the MED SEC (A) is moving forward. Once established, the MED SEC (A) informs supported units that the new location is now open and accepting casualties. The MED SEC (B) clears any remaining casualties and moves to rejoin the MED SEC (A) becoming the consolidated BAS once again. Jumping an entire BAS as a single unit leaves the supported unit in a "wait status" while simultaneously making the BAS vulnerable to unexpected casualties while en route. If an entire BAS is caught jumping, they are forced to stop at an unrehearsed location, pull out equipment, treat, evacuate, repack equipment, and set off again, which can lead to negative secondary and tertiary effects. Careful synchronization with the tactical plan can easily reduce the friction of jumping a consolidated BAS, but bounding the MED SEC (A)/MED SEC (B) creates a

controlled, consistent coverage while distributing the workload as they move (see figure 1-14).

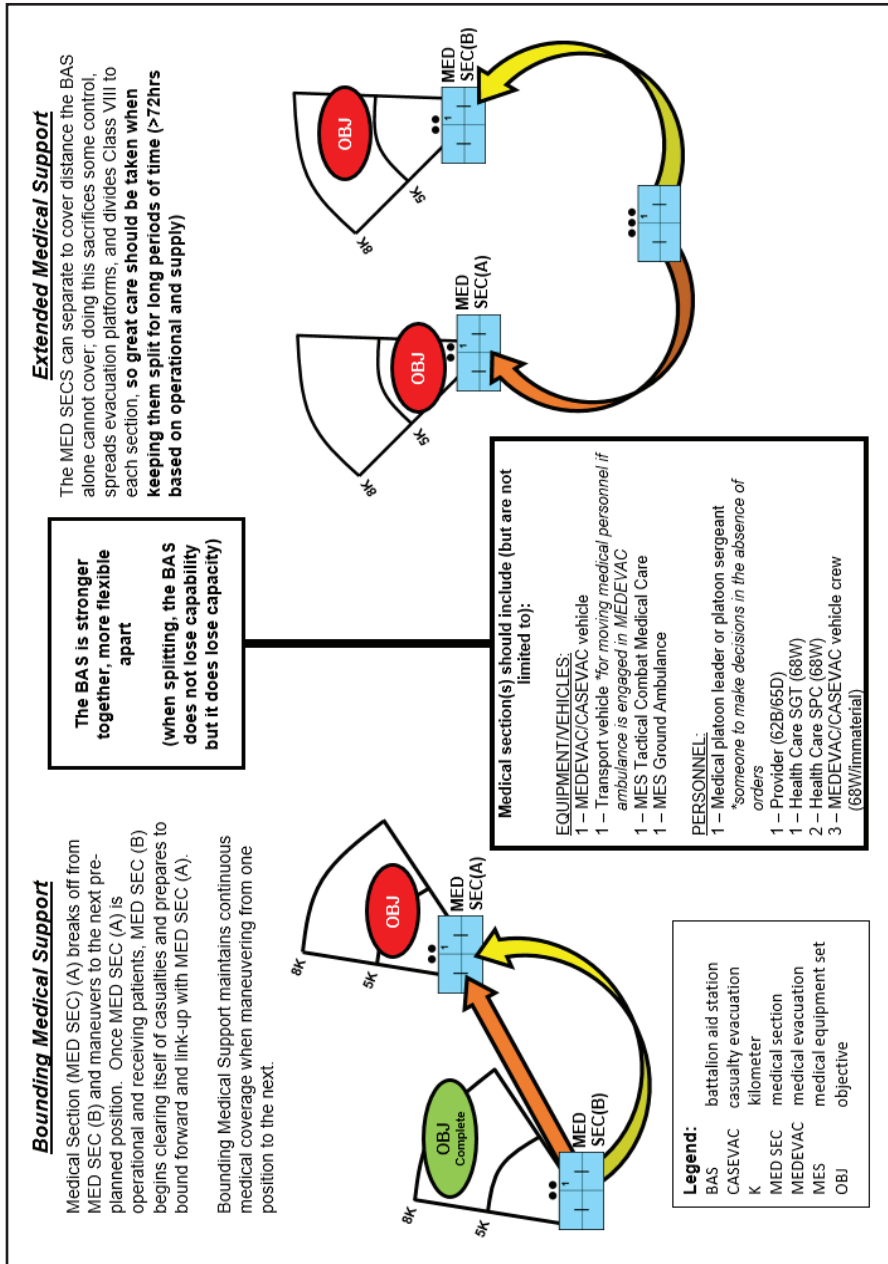

Figure 1-14. Extended medical support techniques

1-140. Splitting into MED SEC (A) and MED SEC (B) is a useful capability in high OPTEMPO environments where tactical conditions can change rapidly and without warning. A Role 1 BAS that can operate independently and respond quickly to fluctuating battlefield geometry will see the most success with MED SEC (A)/MED SEC (B) operations, but battalion medical planners, along with battalion staff, must carefully consider the risks and rewards inherent to splitting a BAS into MED SEC (A)/MED SEC (B) or risk overwhelming one or both medical nodes. If used correctly, the MED SEC (A)/MED SEC (B) can add a limited extension of medical support adding flexible support to broad tactical plans, and/or create an unbroken flow of medical support as maneuver elements progress through objectives.

PROLONGED CARE

1-141. Prolonged care is a set of conditions pre-planned and executed on order at the tactical and strategic level that require a unit to extend their TFC operations. At the Role 1 BAS they become considerations that the medical platoon forecasts in planning medical support. To ensure the delivery of prolonged care it should be rehearsed. The medical platoon leadership should take into account the following:

- The potential of leaving medical assets with wounded as the unit moves forward.
- Management of casualty response events that include triage with limited resources and delayed evacuation procedures.
- Additional evacuation platforms required to move patients.
- The need for en route care.
- Classes of supply requirements, especially Class VIII, and consideration of additional planning, space, and transportation requirements needed to perform this task.
- The development of rehearsed TTPs to address prolonged care such as the use of “makeshift patient holds” like a lean to or an unmanned ambulance.
- Additional training requirements medical personnel may need to execute prolonged care at the Role 1 BAS level.

AMBULANCE SQUAD

1-142. Medical platoon ambulances provide evacuation within the battalion. Ambulance squads are either wheeled or tracked and provide MEDEVAC within the battalion. Each ambulance is equipped with an MES, ground ambulance. The ambulance squad sends out teams that provide MEDEVAC and en route care from the Soldier’s POI or a CCP to the BAS. Each ambulance team consists of an emergency care sergeant or specialist and two ambulance/aide drivers and is normally dedicated to support a specific company unless otherwise directed by the platoon leader. In MASCAL situations, nonmedical vehicles may be used to assist in CASEVAC as directed by the commander. Plans for the use of nonmedical vehicles to perform CASEVAC should be included in the battalion’s TACSOP and during rehearsals.

1-143. The number of ambulance in a squad varies and is based on the type of parent organization. The infantry, airborne, air assault, and Stryker maneuver battalions’

ambulance squads are equipped with wheeled ambulances. The combined arms battalion ambulance squad is equipped with tracked ambulances. The ambulance squad consists of between four and eight teams depending on type of battalion assigned.

AMBULANCE TEAM

1-144. The ambulance team is essentially a mobile combat medic team. Members of the ambulance team are trained and certified in EMT procedures. Additionally, the ambulance team must be confident in land navigation to guarantee efficient travel between the various medical nodes on a battlefield. They operate and maintain the ambulance and all onboard equipment. The ambulance team's principal function is to collect and treat the sick and wounded on the battlefield and to safely evacuate them to the nearest role of care or AXP. For communications, the ambulance team employs an FM tactical radio mounted on its assigned ambulance. The team normally deployed on the medical platoon's operations net; however, in certain circumstances it may be permitted to operate in the administration and logistics (A/L) network or as established by the battalion communications-electronics operation instructions. The ambulance team can utilize Graphic Training Aid (GTA) 07-40-001 for a quick reference to map reading and land navigation.

1-145. The ambulance team routinely deploys with the CTCP however, it operates as far forward as the tactical situation permits, and frequently finds and treats patients who have not been seen by the company's combat medics. This team, when operating in a rifle company's AO, is normally under the tactical control of the company XO or ISG, but remains under the technical and operational control of the medical platoon. An ambulance team is normally designated to support a specific rifle, tank, Stryker, or weapons company. To become familiar with the specific terrain and battlefield situation, the team maintains contact with the supported unit during most combat operations.

1-146. During static situations where the company is not in enemy contact, the team returns to the Role 1 BAS to serve as back-up support for other elements in contact. However, during movement to contact, the ambulance team immediately deploys to its regularly supported company. During combat operations, the team may dismount, (leaving the ambulance in the train's area), find, treat and move patients to safety, and later evacuate them to the BAS. When moving patients back to where the ambulance is located (CCP), nonmedical personnel normally assist the team. Specific duties of the ambulance team include:

- Maintaining contact with supported elements.
- Finding and collecting the wounded.
- Providing TCCC as required.
- Initiating or completing the DD Form 1380.
- Evacuating litter patients to the BAS or air ambulance pick up point.
- Directing or guiding ambulatory patients to the BAS.
- Performing triage when necessary.
- Providing Class VIII resupply to combat medics and CLS.
- Serving as messengers within medical channels.

- Maintaining operational readiness of assigned vehicle.

AMBULANCE EXCHANGE POINT

1-147. *Ambulance exchange point* is defined as a location where a patient is transferred from one ambulance to another en route to a medical treatment facility (MTF). Also called AXP (ATP 4-02.2).

1-148. These AXPs are normally preplanned and are a part of the HSS appendix to the sustainment annex to the operation plan (OPLAN). In the forward area, the threat of enemy ground activities, large concentrations of lethal weapons systems, and effective use of anti-aircraft weapons may dictate that the AXP be a predetermined rendezvous point for the rapid transfer of patients from one evacuation platform to another. The location of AXPs should be frequently changed to preclude attracting enemy fires.

1-149. Ambulance exchange points are established for many different reasons. The goal of an AXP should always strive to achieve medical economy of force with all the MEDEVAC/CASEVAC vehicles involved. Medical planners should endeavor to keep the forward ambulances forward and empty as often and quickly as possible to maximize the effects of limited ground evacuation resources. For example, the ambulance platoon of the armored BSMC, brigade support battalion (BSB) possesses a mixture of wheeled and tracked ambulances. Ambulance exchange points could be established for the following reasons:

- The BSMC's tracked ambulances are provided due to their enhanced protection capabilities given their proximity to the fight. These vehicles are attached to the Role 1 BAS and carry the patients from the Role 1 to the AXP where the BSMC's wheeled ambulances then take over for the relatively longer trip to the rear.
- Ambulance exchange points are not limited to ground evacuation assets. Another example is a situation where the threat air defense artillery capability is such that air ambulances cannot fly as far forward as the BAS, however, an AXP could be established a few kilometers to the rear, still well forward of the brigade support area (BSA).
- The BCT tracked or wheeled ambulances could then transfer the patients to the air assets, thereby facilitating the rapid evacuation of patients and realizing a significant time savings.
- Transferring patients from a slower platform to a faster platform for quicker evacuation.

1-150. By using AXPs, evacuation assets are returned to their supporting positions faster. This facilitates evacuation as the returning crews are familiar with the road network and the supported unit's tactical situation. In the case of air ambulance assets, AXPs are important because of the requirements for integration into the airspace control system at each role and the enhancement to survivability provided by current threat and friendly air defense information. Some considerations when executing an AXP are:

- Do both sending and receiving ambulances have a means to communicate, and has it been rehearsed?
- What alternate tools do each ambulance have to facilitate link-up in low light?

- Do the departing ambulances know the routes to and from the AXP's?
- Do the ambulance teams know future planned locations of the BAS or company in case they move while the ambulance is gone?

AMBULANCE SHUTTLE SYSTEM

1-151. The *ambulance shuttle system* is a system consisting of one or more ambulance loading points, relay points, and when necessary, ambulance control points, all echeloned forward from the principal group of ambulances, the company location, or basic relay points as tactically required (ATP 4-02.2). This system is an effective and flexible method of employing ambulances during operations. This system includes:

- *Ambulance loading point* is the point in the shuttle system where one or more ambulances are stationed ready to receive patients for evacuation (ATP 4-02.2). It is commonly referred to as a "manned AXP".
- *Ambulance relay point* is a point in the shuttle system where one or more empty ambulances are stationed to advance to a loading point or to the next relay post to replace departed ambulances (ATP 4-02.2).
- *Ambulance control point* is a manned traffic regulating, often stationed at a crossroad or road junction, where ambulances are directed to one of two or more directions to reach loading points and medical treatment facilities (ATP 4-02.2). The need for control points is dictated by the situation. Generally, ambulance control points are more necessary in forward areas.

1-152. In the establishment of the ambulance shuttle system, once the relay points are designated, the required number of ambulances are stationed at each point. If the tactical situation permits, the ambulances may be delivered to the relay points by convoy.

1-153. Advantages of the ambulance shuttle system are that the system—

- Places ambulances at CCPs and the Role 1 BAS as needed.
- Permits a steady flow of patients through the system to each role of care.
- Avoids unnecessary massing of transport in forward areas.
- Minimizes the danger of damage to ambulances by the enemy.
- Permits the commander or platoon leader to control their elements and enables them to extend their activities without advancing the headquarters.
- Facilitates administration and maintenance.
- Maximizes the use of small command elements (sections or platoons) to operate the ambulance shuttle without employing the entire parent unit.
- Provides for flexible use of other ambulance assets for specific situations.

STAFFING OF RELAY, LOADING, AND AMBULANCE CONTROL POINTS

1-154. Important points may be manned to supervise the blanket, litter, and patient movement items (PMI) exchange and to ensure that medical messages and medical supplies to be forwarded are expedited. Staffing also helps ensure information is passed along to ambulance teams.

COMBAT MEDIC SECTION

1-155. To foster good interpersonal relations and morale of combat troops, combat medics are attached to maneuver companies on a continuing basis. However, METT-TC dependent, during lulls in combat operations they should return to the medical platoon for consultation and proficiency training. Combat medics are allocated to rifle companies on the basis of one combat medic per platoon and a senior medic (E-5) for each rifle company. In CABs, the allocation is the same for rifle companies, and normally, there is one ambulance team per tank or infantry company. The combat medic makes their assessment, administers initial medical care, initiates a DD Form 1380 and then requests evacuation or returns the Soldier to duty. The combat medic also assists in the training of the platoon's CLSs in enhanced first-aid procedures and requisitions Class VIII supplies from the BAS.

CASUALTY COLLECTION POINT OPERATIONS

1-156. The *casualty collection point* is a location that may or may not be staffed, where casualties are assembled for evacuation to a MTF (ATP 4-02.2). Casualty collection points are normally predesignated along the axis of advance or evacuation routes in coordination with the 1SG. Forward of the Role 1 BAS the combat medic, CLS, and combat troops take casualties to the CCPs. These points facilitate acquisition of casualties by supporting ambulance teams and reduce evacuation time. When used by the BAS, CCPs help preserve BAS mobility, preclude carrying casualties forward, and reduce evacuation time to the sustainment area.

1-157. When designating a CCP, the designating authority makes a decision whether or not to provide medical staff at the location. This decision is based upon the assessment of risk versus the availability of personnel. Normally, the role of care designating the point is responsible for staffing. Medical platoon personnel may not be available to staff these points, and CLSs and ambulatory patients may be required to perform self-aid/buddy aid, or enhanced first aid. The CCPs should be identified on operational overlays and planned by phase for operations. The CCP planning considerations include site security, proximity to the landing zone (LZ), cover and concealment, and access to evacuation routes. Leaders should address aid and litter teams, distribution of casualty equipment, and how choke points can be mitigated.

1-158. When no longer receiving effective enemy fire, the TFC phase of TCCC is entered, allowing more medical intervention. When conducting CCP operations, medical platoon personnel are responsible for activity inside the CCP and the supported unit leadership is responsible for activity outside the CCP. It is recommended that all personnel train on and rehearse operations inside and outside of the CCP. Casualty care and/or medical duties are not restricted to only medical platoon personnel within the CCP.

1-159. If possible, casualty flow should be planned from the POI all the way back to a Role 4 installation MTF in the continental United States. Combat medics should understand the casualty flow up two levels above themselves at a minimum, including patient regulating, casualty accountability, and hospitalization requirements. For

example, a platoon medic should have a good understanding of where a casualty goes after leaving the tactical CCP or BAS.

1-160. There are several questions that need to be answered in order to establish the tactical casualty flow:

- Where are the casualties being evacuated to?
- Will ground, air, or water assets conduct evacuation to the CCP?
- How will evacuation be conducted to casualty transload points?
- What are the distances and times of travel?
- Will expected casualties be able to make it that far? If not, what parts of the plan need to be corrected?
- Who will evacuate the casualties (CASEVAC or MEDEVAC)?
- Are medical assets positioned to ensure continuity of care?
- What is the branch plan if an echelon of care has a MASCAL?
- Does the tactical evacuation plan account for branch and sequels to the operations plan?

Duties and Responsibilities

1-161. The subsequent paragraphs discuss duties and responsibilities of key personnel within the battalion.

Senior Medic/Combat Medic

1-162. During the planning phase, the senior medic/combat medic—

- Provides recommendations and advice to leadership on medical support.
- Plans AHS support by phase of the operation.
- Plans casualty response and evacuation by phase of the operation.
- Recommends to the unit leadership and coordinate as required—
 - Casualty collection point locations by phase.
 - Medical TASKORG and distribution.
 - Ground (on the target) evacuation plan and platforms.
 - Air/ground (off the target) evacuation plan and platforms.
 - Casualty collection point, helicopter landing zone (HLZ), and evacuation platform security.
- Conducts PCI of junior medics, platoon casualty response kits, and CLS tasks.

1-163. During the execution phase, the senior medic/combat medic—

- Performs triage, treatment, monitoring, and packaging.
- Conducts delegation of treatment.
- Requests assistance from other medical or unit assets.
- Provides guidance and recommendations to leadership on casualty management and evacuation.

Battalion Medical Personnel and Medical Planners

1-164. During the planning phase, the battalion medical platoon personnel and medical planners—

- Provide recommendations and advise to leadership on AHS support.
- Participate and advise in CASEVAC planning, coordination, and rehearsals.
- Recommend to the unit leadership and coordinate as required—
 - Casualty collection point locations of subordinate units by phase.
 - Medical TASKORG and distribution.
 - Ground (on the target) evacuation plan and platforms.
 - Air/ground (off the target) evacuation plan and platforms.
 - Casualty collection point, HLZ, and evacuation platform security.
- Provide augmentation requirements of subordinate units.
- Link-in with tactical operations.
- Standardize casualty collection point markings for both day and night. Colors that can be used to denote the patients current medical triage category are:
 - Immediate – Red
 - Delayed – Yellow
 - Minimal – Green
 - Expectant – Black (blue chemical light during hours of limited visibility)
- Plan for patient tracking, patient regulation, and PMI management.

1-165. During the execution phase, the battalion medical platoon personnel and medical planners—

- Perform triage, treatment, monitoring, and packaging.
- Conduct delegation of treatment.
- Request assistance from other medical or platoon assets.
- Provide guidance and recommendations to leadership on casualty management.
- Conduct patient tracking, patient regulation, and PMI management.

Unit Leadership

1-166. During the planning phase unit leadership will—

- Develop the evacuation plan by phase of the operation.
- Plan CCP locations and HLZ/AXP locations.
- Plan and rehearse security of CCP and security of HLZs/AXPs.
- Allocate aid and litter teams and carry evacuation equipment.
- Develop an accountability and reporting plan.
- Manage distribution/TASKORG of medical platoon personnel.
- Perform PCI of junior medics, platoon casualty response kits, and CLS tasks.
- Conduct casualty response rehearsals.

- 1-167. During the execution phase, the unit leadership will—
- Establish and secure CCP.
 - Provide assistance to medics with EMT augmentation and direction of aid and litter teams.
 - Gather and distribute casualty equipment and sensitive items.
 - Provide accountability and report to higher.
 - Request evacuation and establish CASEVAC link-up point.
 - Manage killed in action human remains.

Casualty Response Rehearsals

1-168. The casualty response rehearsal is critical in planning and overall unit rehearsals. During TLP the battalion rehearses the CCP plan per unit SOP. A good practice is for the medical platoon leadership to include CCP rehearsals into the OPOD when conducting MDMP. This will ensure the battalion rehearses this critical battle drill. Listed below are some areas to concentrate on when conducting a casualty response rehearsal:

- Each element should rehearse CASEVAC plans.
- Each element should rehearse alerting aid and litter teams and movement of a casualty—
 - Alert and movement.
 - Evacuation equipment preparation.
 - Clearing and securing weapons.
- Casualty collection point members rehearse the following:
 - Clear and secure CCP location.
 - Choke point and triage.
 - Mark and tag (to include both day and night per unit TACSOP).
 - Account and report.
 - Remove equipment tag and consolidate.

Casualty Collection Point Site Selection

1-169. Selecting a site for the CCP should be addressed during the course of action (COA) development step of MDMP and TLP. However, METT-TC will become a factor as operations commence. Listed below are some factors to consider a tactical location for a CCP:

- Proximity to the fight (see figure 1-15).
- Near templated areas of expected high casualties.
- Cover and concealment.
- In building or on hardstand (exclusive CCP building limits confusion).
- Access to evacuation routes (foot, vehicle, and aircraft).
- Proximal to “Lines of Drift” or paths across terrain that are the most likely to be used when going from one place to another.

- Adjacent to objective choke points (breaches, building, or HLZs) (see figure 1-16 on page 1-56).
- Avoid natural or enemy choke points.
- Area allowing passive security (inside the perimeter).
- Good drainage.
- Trafficable to evacuation assets.
- Expandable if casualty load increases.

Note. “Lines of Drift” are paths of least resistance that offer the greatest ease while taking into account obstacles and modes of transit to the objective.

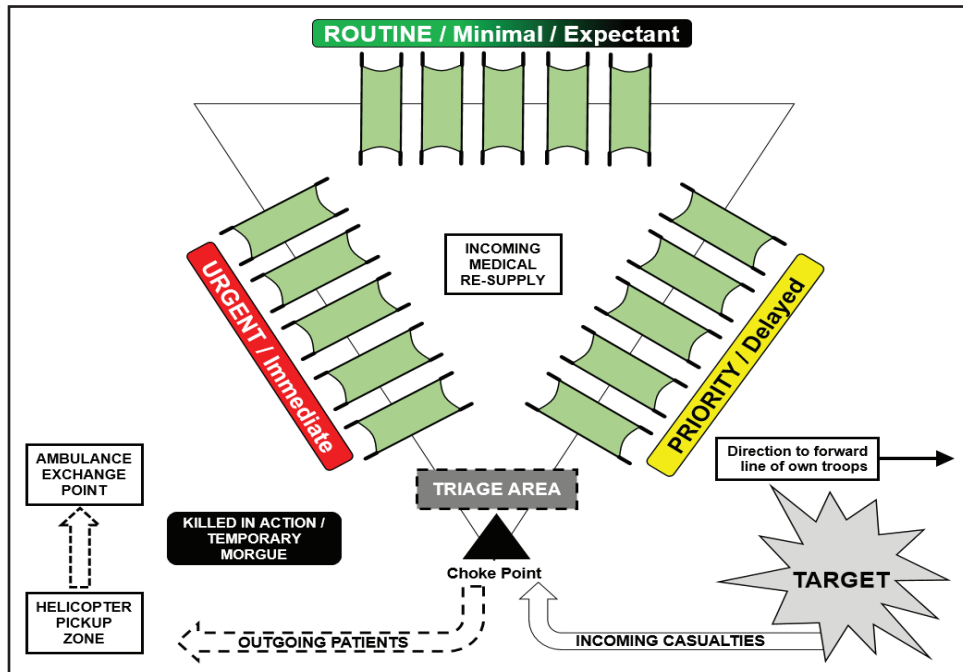

Figure 1-15. Example, casualty collection point, open area or field

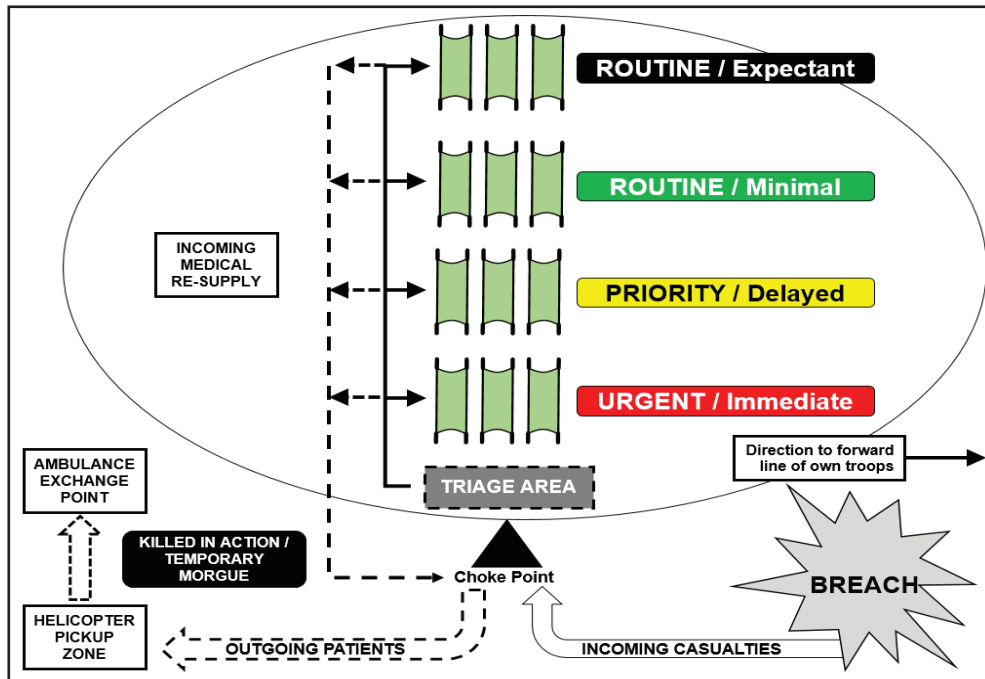

Figure 1-16. Example, notional casualty collection point at a breach

Casualty Collection Point Operational Guidelines

1-170. Just as site selection of a CCP is addressed during MDMP, as the unit conducts TLP, the CCP SOP should be rehearsed.

1-171. Typically the 1SG or PSG is responsible for casualty flow and everything outside the CCP. The 1SG or PSG ensures minimal casualties remain with original element or assist with CCP security if possible. They also ensure that killed in action remain with their organic element. Listed below are additional guidelines for the 1SG and/or PSG:

- Provides for CCP structure and organization (color coded per SOP for both day and night).
- Maintains C2 and battlefield situational awareness, to include security.
- Controls aid and litter teams and provides security.
- Strips, bags, tags, organizes, and maintains casualty equipment outside of treatment area as possible.
- Accounts for tracking casualties and equipment into and out of CCP and provides reports to higher.
- Moves casualties through CCP entrance and exit choke point which should be marked per SOP.
- Calls for MEDEVAC/CASEVAC when required.

- Minimal casualties should remain with original element or assist with CCP security if possible.
- Killed in action should remain with their organic element.

1-172. Medical platoon personnel are responsible for everything inside the CCP. Discussed below are examples of duties inside the CCP:

- Triage officer/NCO sorts and organizes casualties at choke point into appropriate treatment categories.
- Medical officers and medics organize medical equipment and supplies and render treatment to casualties.
- Medical platoon personnel, CLS, and aid and litter teams assist with treatment and packaging of casualties.

Casualty Collection Point Building Guidelines

1-173. When conducting operations in built-up areas establishing a CCP in a building may be the only choice (see figure 1-17 on page 1-58). After the unit ensures that building is cleared and secured consider the following:

- Enter and assess the building prior to receiving casualties.
 - Use largest rooms.
 - Rigid litter or nonrigid poleless litter movement (can it be done in the area?)
 - Separate rooms for treatment categories.
 - Determine location of choke point
 - Determine location of triage area.
 - Minimize congestion.
- Remove or relocate furniture or obstructions.
- Color-code rooms to treatment categories (mark doors).

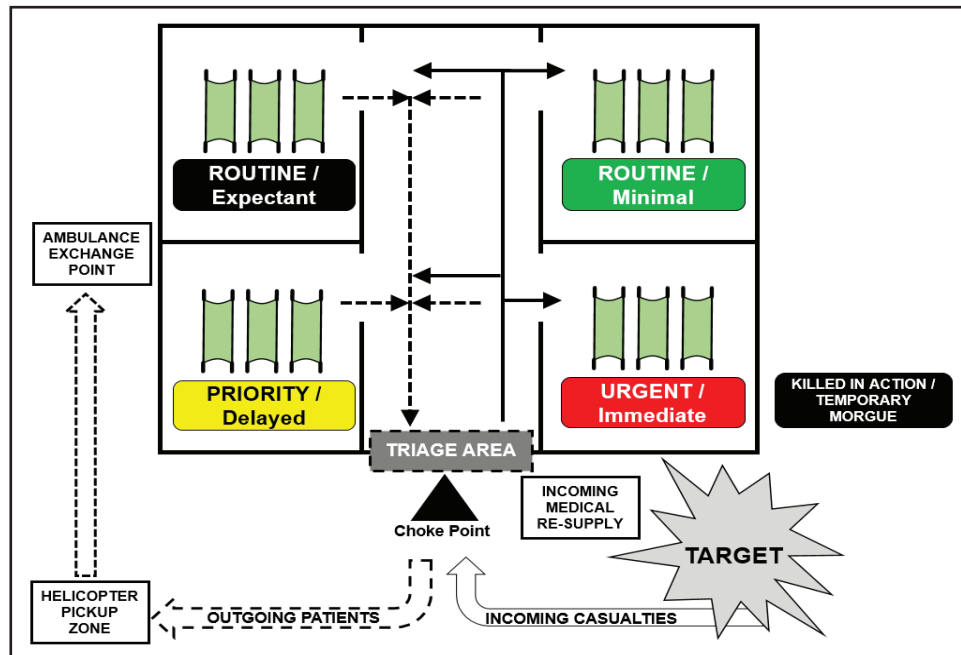

Figure 1-17. Example, casualty collection point in a building

Casualty Collection Point Evacuation Guidelines

1-174. These guidelines may be used as a planning template but should be modified based on the objective and mission variables. Evacuation is a logistical challenge, below is a list of considerations that can assist the combat medic in getting their patients evacuated:

- Does the medical platoon personnel know the evacuation platform?
 - Are medical personnel on board?
 - Is monitoring equipment available?
 - How many casualties can platform evacuate?
- What are the packaging requirements for patients per TACSOP?
 - Type litters?
 - Use of stirrups?
 - Is floor loading allowed?
- What is the flow of casualties to the evacuation platform?
- What is required for a large platform?
 - What is the priority for multiple casualties—routine on first?
 - Priority on next.
 - Critical (urgent) on last, so they are first off at destination.

- Small platform. Medical platoon personnel need to consider the following:
 - How are critical (urgent) patients packaged?
 - What is the priority of evacuation?
- Who is providing security for the evacuation assets or is security assumed?
- What risk versus reward determines this decision?

SECTION VI – BRIGADE AND ECHELON ABOVE BRIGADE MEDICAL ASSETS IN SUPPORT OF THE MEDICAL PLATOON

1-175. This section provides information on brigade and EAB medical units supporting the medical platoon.

BRIGADE SURGEON

1-176. The brigade surgeon is a member of the commander's personal and special staff. The brigade surgeon is assigned to the HHC of a brigade, and normally work under the staff supervision of the brigade executive officer. The brigade surgeon plans and coordinates the brigade AHS support activities with the brigade's personal, special, and coordinating staffs. The brigade surgeon is responsible for the technical control of all medical activities in the command. The brigade surgeon oversees and coordinates AHS support activities through the brigade surgeon section and the brigade operation staff. The brigade surgeon keeps the brigade commander informed on the status of AHS support for brigade operations and the health of the command. The brigade surgeon provides input and obtains information to facilitate medical planning. The brigade surgeon's specific duties in this area include, but are not limited to:

- Build and maintain a brigade-level MEDCOP.
- Ensure implementation of the AHS support section of the brigade TACSOP.
- Participate in the battalion's operations staff protection cell working group to integrate and synchronize FHP tasks and systems for each phase or transition of an operation or major activity. Prepares a portion of Annex E (Protection) to the OPORDs and plans.
- Participate in the battalion logistics staff's sustainment cell working group to integrate and synchronize HSS tasks. Prepares a portion of Annex F (Sustainment) to the OPORDs and plans.
- Determine the allocation of medical resources within the brigade.
- Supervise technical training of medical platoon personnel and the CLS program within the brigade.
- Determine procedures, techniques, and limitations in the conduct of routine medical care, EMT, and trauma management.
- Monitor aeromedical and ground ambulance evacuation.
- Monitor the implementation of automated medical systems.
- Inform the division surgeon on the brigade's AHS support situation.
- Monitor the health of the command and advises the commander on measures to counter disease and injury threats.

- Exercise technical supervision of subordinate battalion surgeons and PAs.
- Provide consultation and mentoring for subordinate field surgeons (battalion surgeons) and PAs.
- Provide the medical estimate and health threat for inclusion in the commander’s estimate.
- Provide oversight and supervision of the Controlled Pharmaceutical Quality Control and Surveillance Program.

1-177. The brigade surgeon utilizes medical command and control to coordinate and synchronize the 10 medical functions split between the protection and sustainment warfighting functions and serve as a link between these varied commands and staffs.

BRIGADE SURGEON'S SECTION

1-178. The brigade surgeon is accompanied by a MEDO and a battle staff-qualified health care NCO. These three medical personnel (see table 1-4) comprise the brigade surgeon’s section.

Table 1-4. Brigade surgeon section

<i>Paragraph title</i>	<i>AOC/MOS</i>	<i>Grade</i>	<i>Title</i>	<i>Branch</i>	<i>Quantity</i>
Sustainment– S-4/Medical	62B00	O4	Field Surgeon	MC	1
	70H67	O3	Medical Operations Officer	MS	1
	68W4O2S	E7	Health Care NCO	NC	1
Legend:					
2S	battle staff operations		MS	medical service corps	
AOC	area of concentration		NC	noncommissioned	
MC	medical corps		NCO	noncommissioned officer	
MOS	military occupational specialty				

1-179. The brigade surgeon section is assigned to the HHC of the brigade and operates out of the brigade tactical operations center. This section is an integral part of the brigade’s main command post and the staff of the brigade surgeon is intimately involved with the operations staff and their staff in the planning process. The section, in coordination with the brigade logistics staff the BSMC commander, BSB support operations (SPO) medical section, and battalion surgeons, is responsible for the development of the medical portion of the brigade OPLAN/OPORD and takes part in the brigade MDMP. This section is responsible to the brigade commander for staff supervision of AHS support operations within the brigade. The brigade surgeon section is also responsible for coordinating general support and direct support relationships of organic medical units and medical units/elements whether operational control or attached to the brigade. This section updates the brigade commander as required on the status of AHS support operations in the brigade. The staff of the brigade surgeon section assists the brigade surgeon in planning and conducting brigade AHS support operations. Specific functions include, but are not limited to:

- Provide current information on the brigade AHS support plan/MEDCOP to surgeons/medical operations staffs of the next higher, adjacent, and subordinate headquarters to maintain medical situational awareness.
- Plan and ensure the timely and efficient establishment of Roles 1 and 2 AHS support for the brigade.
- Plan and coordinate AHS support operations for brigade medical assets, attached, or operational control EAB assets. This includes reinforcement and reconstitution.
- Coordinate with the division surgeon section for prioritizing the reallocation of organic and corps medical augmentation assets as required by the tactical situation.
- Ensure that the medical annex of the brigade TACSOP, plans, policies, and procedures for AHS support, prescribed by the brigade surgeon, are prepared and executed.
- Oversee medical training and provides information to the brigade surgeon and brigade commander.
- Coordinate and prioritize MEDLOG and blood management requirements for the brigade.
- Collect health threat information and coordinate medical intelligence requirements with the brigade intelligence staff.
- Coordinate and direct patient evacuation from forward areas to supporting BAS.
- Coordinate the MEDEVAC of all detainee casualties from the brigade AO.
- Coordinate the disposition of captured medical materiel.
- Coordinate, plan, and prioritize operational public health missions.
- Coordinate with the supporting veterinary element for subsistence and animal disease surveillance.
- Coordinate and monitor patient decontamination operations to include:
 - Layout and establishment of PDS.
 - Use of collective protection.
 - Use of nonmedical Soldiers to perform patient decontamination procedures under medical supervision.

ADDITIONAL MEDICAL ASSETS OPERATING IN THE BRIGADE AREA OF OPERATIONS

1-180. The medical platoon leader and PSG should be familiar with the types of organic and EAB medical units that support the brigade. Listed below are some of the units that doctrinally support the brigade in either a general or direct support role. Knowing this and fostering relationships with these units will improve the overall AHS support plan developed for the battalion.

BRIGADE SUPPORT MEDICAL COMPANY

1-181. The BSMC provides Role 2 AHS support to supported maneuver battalions with organic Role 1 BASSs. This company provides both Roles 1 and 2 medical treatment on an area basis to those units without organic medical assets operating in the BSA. This AHS support includes medical staff advice and assistance as required on an area basis to all units in the brigade area of operation. The company also provides unit level AHS support to units without organic medical support. Figures 1-18 through 1-21 on pages 1-63 through 1-65 show the organizational structures and layout of the BSMC. The BSMC consists of a company headquarters, brigade medical supply section, preventive medicine section, mental health section, treatment platoon, and evacuation platoon. For more information on the BSMC see ATP 4-02.3 and ATP 4-90. The BSMC performs the following services and functions:

- Provision of AHS support advice to the brigade and BSB commander.
- Provide medical command and control of attached units, which include medical planning and coordination of patient movement within and outside of the brigade.
- Treatment of patients with DNBI, COSR, triage of MASCAL, initial resuscitation and stabilization, advanced medical treatment, and preparation for further evacuation of patients incapable of returning to duty.
- Augmentation of BAS with ambulance teams to provide ground evacuation for patients from BAS to designated AXP.
- Ground evacuation for patients from AXP to BSMCs.
- Class VIII medical supply and resupply, medical equipment, medical unique repair parts, and medical maintenance support to units in the brigade AO.
- Provide set up and support for medical communication for combat casualty care (MC4) systems and DCAM Level I to the Role 1 BAS.
- Operational dental care that consists of emergency and essential dental care designed to circumvent potential dental emergencies.
- Provide physical therapy support on an area support basis.
- Medical laboratory and radiology services commensurate with a Role 2 BSMC.
- Outpatient consultation services for patients referred from any Role 1 BAS.
- Patient holding for up to 20 patients able to return to duty within 72 hours.
- Operational public health and consultation service for brigade units.
- Provide operational public health support on an area support basis.
- Upon request, provide field sanitation team training and health threat planning in support of the CCIR to subordinate medical units.
- Limited reinforcement and augmentation to supported maneuver battalion medical platoons.
- Regeneration of severely attritted BAS.
- Treatment squads that are capable of operating independently for limited periods of time that provide advanced medical treatment and sick call as

- required. A treatment squad is capable of breaking down into two treatment teams, which can also operate independently for limited periods.
- Provision of medical supervision for PAs in unit-level medical elements without an assigned field surgeon.

Note. The Stryker BSMC has two distinct differences. One, it does not have a separate BMSO section. This capability is imbedded within the company headquarters. And two, it does not have a medical treatment squad with two treatment teams. It has a medical treatment section with three medical treatment teams assigned.

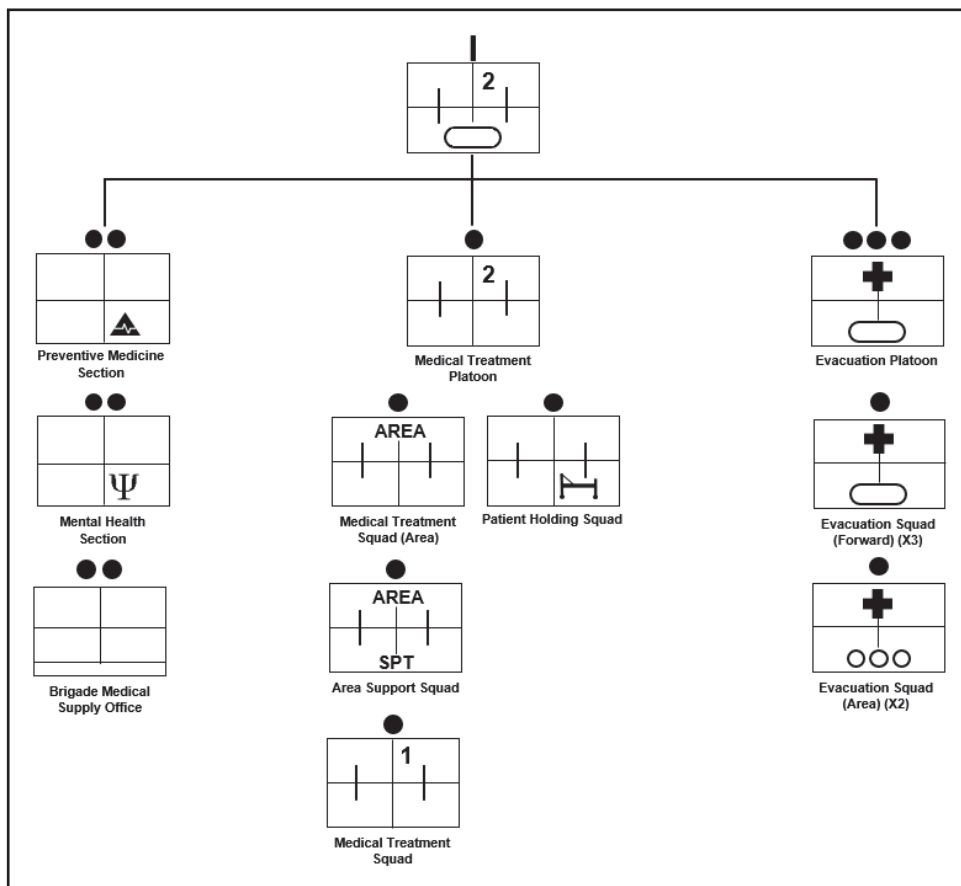

Figure 1-18. Brigade support medical company, armored brigade combat team

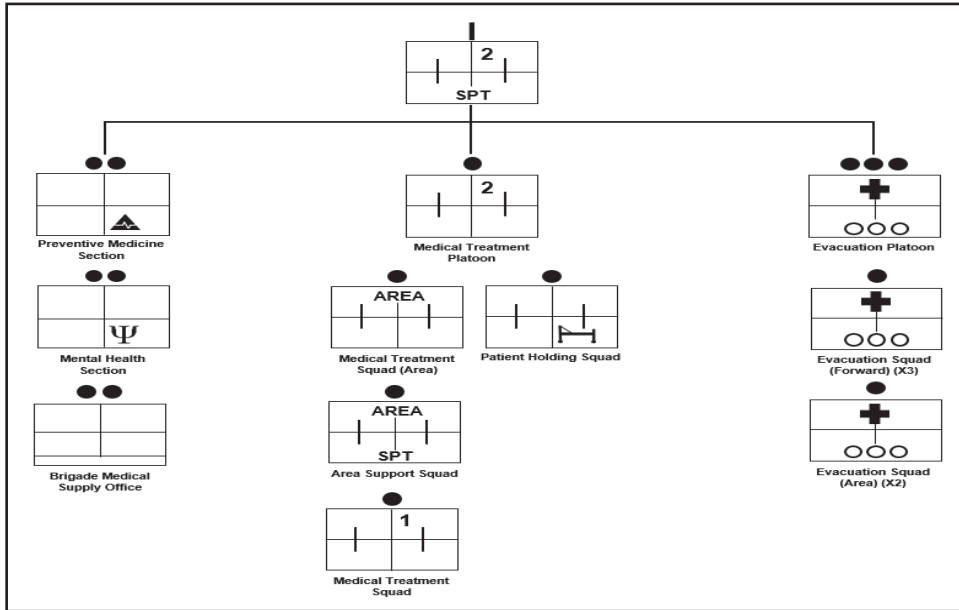

Figure 1-19. Brigade support medical company, infantry and airborne brigade combat team

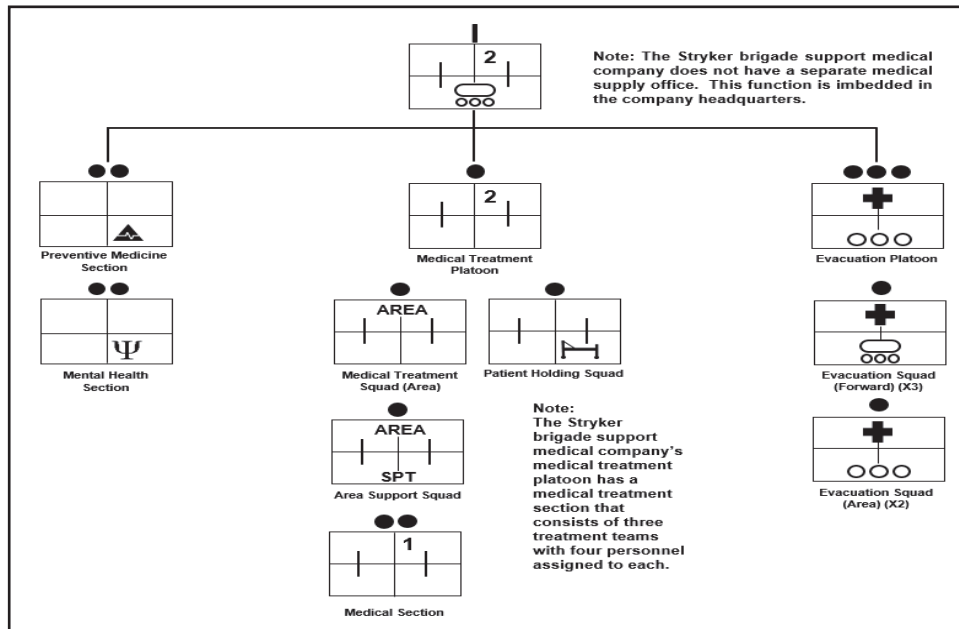

Figure 1-20. Brigade support medical company, Stryker brigade combat team

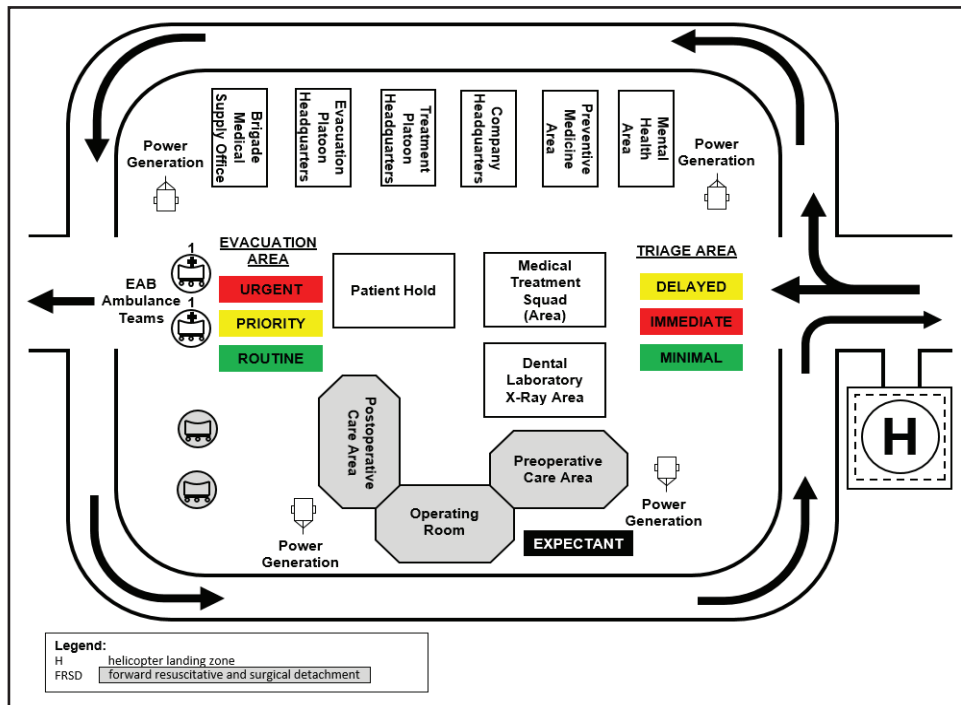

Figure 1-21. Example, brigade support medical company with attached forward resuscitative and surgical detachment layout

FORWARD RESUSCITATIVE AND SURGICAL DETACHMENT

1-182. The forward resuscitative and surgical detachment (FRSD) provides forward damage control resuscitation and damage control surgery in support of unified land operations, either independently, or as part of a future unified action partner coalition, for short and extended military HSS operations. It is normally assigned to a medical brigade and attached to a hospital center when not operationally employed and further attached forward to a BSMC or medical company area support. See ATP 4-02.25 for more information on the FRSD. This unit provides—

- A standardized, rapidly deployable, networked, self-mobile, modular and scalable resuscitative and surgical team capable of supporting short (<72hr) and extended (>72hr) operations, including the ability to support extended medical support operations.
- The team will be modular and scalable, with the ability to provide emergency treatment to receive, triage, and prepare incoming patients for surgery; and provide the required surgery and continued postoperative care.

1-183. The organizational construct of a complete FRSD includes an Administration/Supply Section, a forward resuscitative section, and a forward surgical section (20 personnel).

1-184. In this configuration, the detachment is designed and equipped to receive, triage, provide emergency treatment, and prepare up to 30 incoming patients for damage control resuscitation and/or damage control surgery. Additional capabilities include provision of continued postoperative care for these critically wounded/injured patients over a 72 hour period using its organic MES. The detachment can manage and provide postoperative care for up to eight patients and for up to six hours following surgery while waiting for medical evacuation to the next higher role of medical care (see figure 1-22).

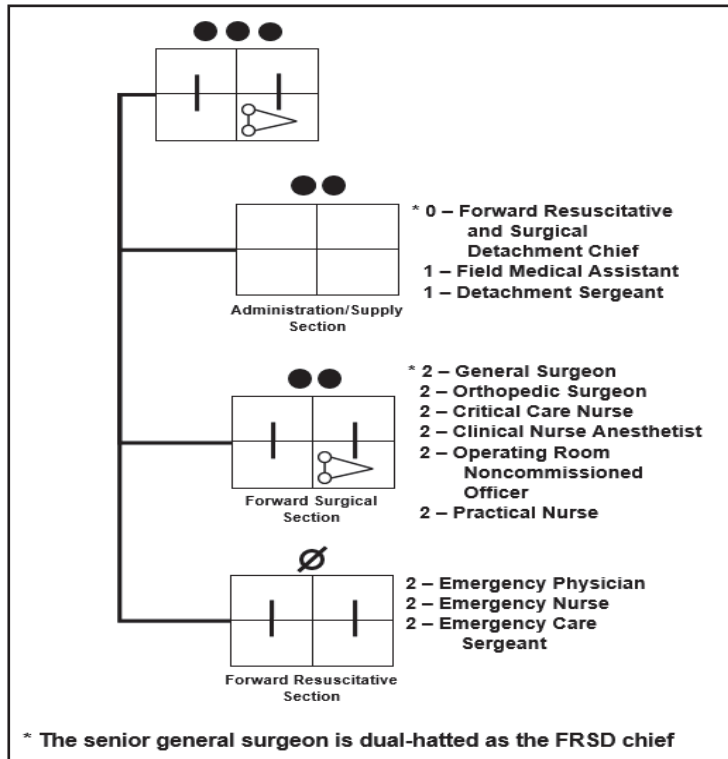

Figure 1-22. Complete forward resuscitative and surgical detachment

1-185. There are situations when it may be necessary for the FRSD to provide forward resuscitative and surgical support for multiple units conducting concurrent operations. To meet this requirement, the detachment is staffed and equipped to divide the Administration/Supply Section, the forward resuscitative section and the forward surgical section evenly in order to form two composite forward resuscitative and surgical sections thus establishing a split FRSD (figure 1-23 on page 1-67 depicts a split FRSD).

1-186. In this configuration, the FRSD provides emergency treatment to receive, triage, and prepare 12 incoming casualties for surgery over a 72-hour period; provides the required surgery and continued postoperative care for critically wounded/injured patients with organic MES. Postoperative care can manage four patients over six hours post-surgery.

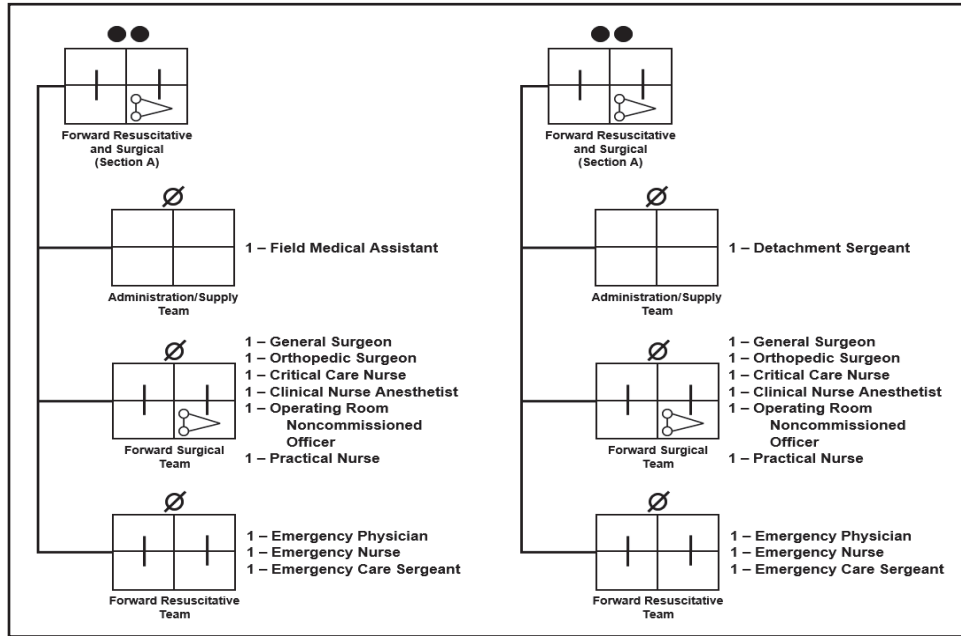

Figure 1-23. Split forward resuscitative and surgical detachment

1-187. Two surgical elements, capable of supporting very short duration (24 hours) operations, consisting of only a surgical element (six personnel). In its smallest configuration, the single surgical element provides emergency treatment to receive, triage, and prepare four incoming casualties for surgery; provides the required surgery and limited continued post-operative care for those critically wounded/injured patients over a period of 24 hours with its organic MES.

1-188. The team is the smallest element within the detachment and constitutes the fundamental building block on which the FRSD is built. Based on this design, the detachment chief can, under certain circumstances send a single surgical team forward to provide limited forward surgical support.

1-189. In this configuration, the forward surgical team provides EMT to receive, triage, and prepare up to four (4) incoming casualties for surgery. The forward surgical team provides the required surgery and limited continued postoperative care for those critically wounded/injured patients for up to 24 hours (short duration) with its organic MES.

1-190. Technical advice and assistance to the supported unit surgeon and the surgeon section/medical operations center for the surgical services portion of the supported unit plans and policies.

1-191. Also, when the FRSD is not forward deployed to a Role 2 it provides surgical augmentation of the Role 3 hospital center's or field hospital's surgical capability.

Note. As written in the section one of the FRSD’s TOE, the terms, elements, teams, and sections are used interchangeably. To avoid confusion, this publication specifically points out the type of element discussed, for example, detachment, section, or team.

MEDICAL COMPANY, GROUND AMBULANCE, AMBULANCE SECTION

1-192. The medical company, ground ambulance provides ground evacuation within the joint operations area. It is normally assigned to a medical battalion (multifunctional) (MMB) (see figure 1-24). The company as two ambulance sections assigned with 12 ambulances each. This section may be attached to the BSMC or a medical company, area support in direct support of the BCT. The ambulance section provides—

- Single lift evacuation of 48 litter patients or 96 ambulatory patients, or a combination of both.
- Evacuation of patients from the BSMC and medical company area support to supporting hospitals.
- Reinforcement of BSMC evacuation assets.
- Reinforcement of covering force and deep battle operations.
- Movement of patients between hospitals and en route patient staging systems, railheads, or seaports in brigade and EAB areas.
- Area evacuation support beyond the capability of the medical company area support.
- Emergency movement of medical supplies.

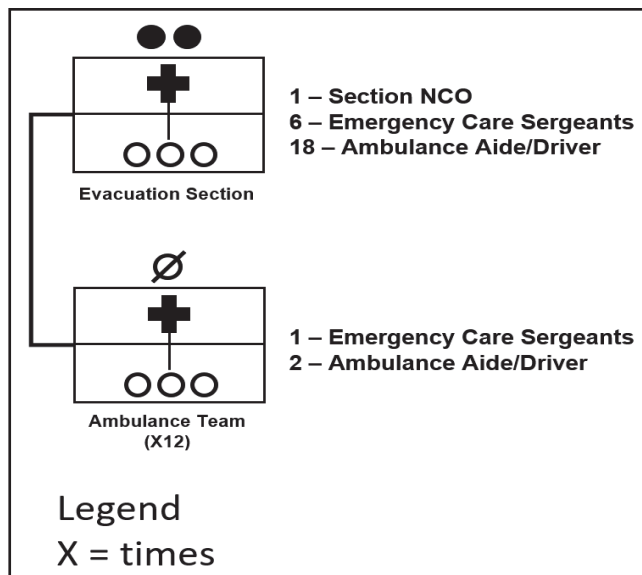

Figure 1-24. Ground ambulance section

PREVENTIVE MEDICINE TEAM

1-193. The preventive medicine detachment provides technical consultation support on public health issues throughout the theater of operations. It constitutes three separate preventive medicine teams (see figure 1-25 on page 1-70). Generally one of these teams may be attached to a BCT. This team collocates with the preventive medicine section of the BSMC to ensure coordination of support efforts. This team provides—

- Ability to gather information systematically to input into an automated medical surveillance system to produce real-time tactically significant health threat profiles.
- Guidance to the command concerning personnel protective measures by performing a medical assessment of the command and the potential impact of DNBI on military operations.
- Epidemiological investigations to include case-contact interviewing, contact tracing, and outbreak investigations.
- On-site water quality analysis.
- Monitoring of water and field ice production and distribution.
- Collection of water, soil, and air samples from sources that may pose environmental, occupational, or industrial hazards to United States troops for definitive analysis by EAB/continental United States laboratories.
- Food service sanitation inspections of field feeding sites.
- Monitoring and guidance on proper field sanitation and waste disposal techniques.
- Guidance on the prevention of climatic injuries (heat, cold, and altitude).
- Direct pest management support including aerial spray missions utilizing aerial spray equipment.
- Direct medical entomology consultation on—arthropod-borne disease; use of pesticides; poisonous plants and animals; and measures for control or avoidance of disease vectors of military significance.
- Collection of water and ice samples for CBRN surveillance and establishment and maintenance of a chain of custody for samples, and forwarding samples to supporting medical laboratories for identification.
- Coordination with the chemical corps CBRN reconnaissance and biological detection units for collection of air and soil environmental samples for laboratory analysis.
- Information on specific personnel protective measures to counter health threats.
- Training and certification for field sanitation team and food service personnel.
- Health promotion education.
- Inspection of cargo destined out of theater for plants, arthropods, rodents, soil, and other items as specified to prevent their introduction into the United States, its territories and possessions, or other nations.

- Assistance in the issuance of vessel clearances for entry into the destination ports, as authorized.
- Running estimates of health threats in the AO.

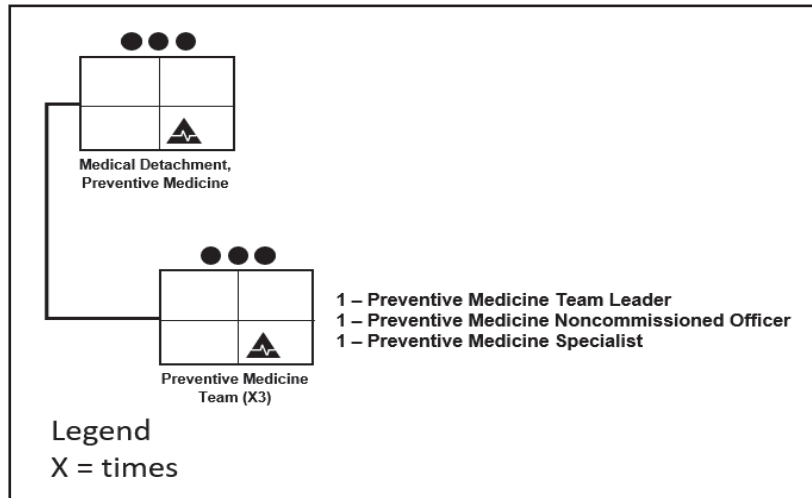

Figure 1-25. Preventive medicine team

VETERINARY SERVICE SUPPORT TEAM

1-194. The veterinary service support team (VSST) is required to support early entry capability to provide Veterinary Roles 1 and 2 medical and resuscitative surgical care to military and DOD contract working dogs, and support initial theater food protection requirements. The VSSTs will provide manpower and equipment to support stability tasks to include civil-military and humanitarian assistance operations and to support special operations forces (SOF). In addition to the Veterinary Roles 1 and 2 animal treatment team, each VSST provides the modularity and flexibility to disperse food inspection teams to two locations to maximize food protection support throughout the area of responsibility. There are five VSSTs assigned to a medical detachment veterinary service support (MDVSS) (see figure 1-26). See AR 40-3 and AR 40-905 for more information on veterinary care. The VSST provides—

- Early entry capability to provide Veterinary Roles 1 and 2 medical and resuscitative surgical care for up to 50 military and/or DOD contract working dogs and support initial theater food protection requirements.
- Food protection support to include food safety, defense, quality, and sanitation inspections for up to 10,000 personnel.
- Presumptive laboratory analysis of food and bottled water in the area of operations.
- Food protection audits of commercial food facilities and sanitation inspections of military food facilities to include assessment of potential military construction sites for food production or storage in the area of operations.

- Installation food defense vulnerability assessments in the area of operations.
- Food and water risk assessments in the area of operations.
- Surveillance inspection of CBRN contamination of Class I subsistence in the area of operations, as directed.
- Manpower and equipment to support all phases of stability operations, to include civil-military and foreign humanitarian assistance tasks, and SOF.
- Modularity and flexibility to disperse two food inspection teams to two separate locations to maximize food protection support throughout the area of responsibility.

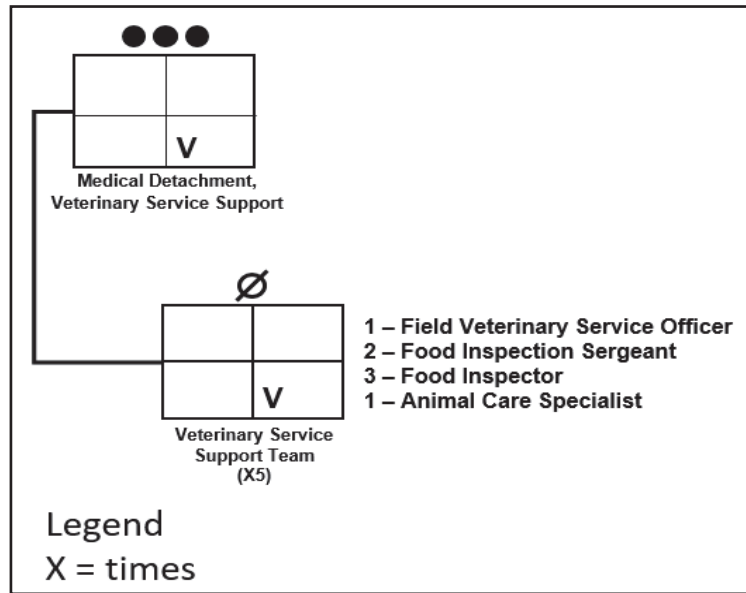

Figure 1-26. Veterinary service support team

COMBAT AND OPERATIONAL STRESS CONTROL FORWARD SUPPORT SECTION

1-195. The forward support section performs prevention and limited fitness activity support to maneuver brigades and area support to units in the BSA. This section deploys in support of a division or BCT as required. The forward support section will require medical command and control to be provided by the supported unit. This section has the capability to break down into six 3-man teams which are sent forward to augment BCTs. It is normally assigned to the medical detachment, combat and operations stress control (see figure 1-27 on page 1-72). The COSC forward support section provides—

- Preventive consultation and stress education support to leaders, chaplains, and medical personnel.
- Neuropsychiatric care, triage, and stabilization.

- Assistance to nonmedical units with rest category COSR casualties and the return to duty of recovered COSR Soldiers.
- Reconstitution to supported units.
- Debriefings after critical events, after action reports, case evaluation, and neuropsychiatric triage and stabilization.

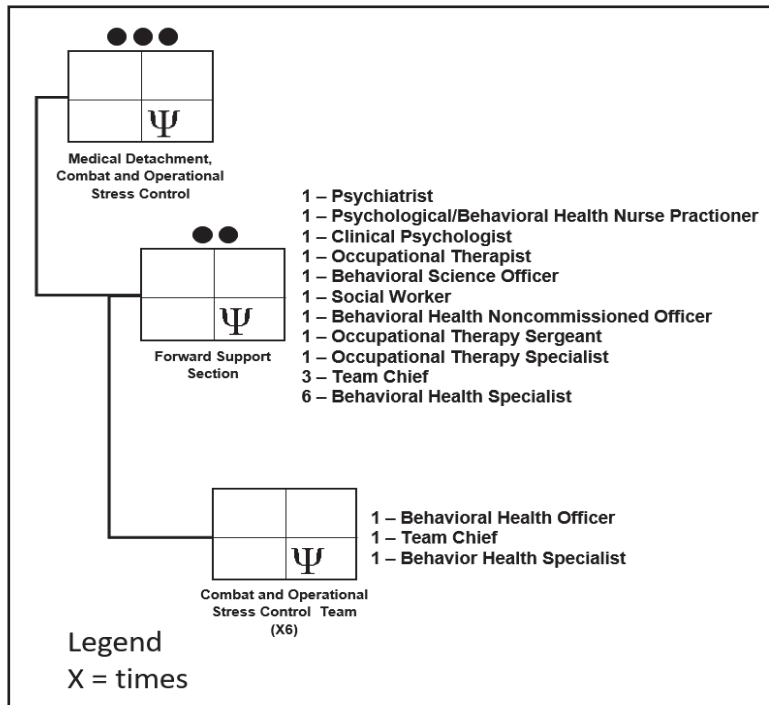

Figure 1-27. Combat and operation stress control forward support section

FORWARD SUPPORT MEDICAL EVACUATION PLATOON

1-196. To provide AE support within the brigade, this platoon is one of four forward support MEDEVAC platoons assigned to the medical company, air ambulance (15 aircraft) general support aviation battalion that is assigned to the division combat aviation brigade (see figure 1-28). This platoon provides—

- Three helicopter ambulances to evacuate critically wounded or other patients consistent with evacuation priorities and operational considerations, from points as far forward as possible, to the brigade Role 2 BSMC or any Role 3 hospital center of field hospital supporting the brigade. Total lift capability utilizing one aircraft is six litter patients or seven ambulatory patients, or some combination thereof (optimally two litter and three ambulatory).
- Total lift capability utilizing all assigned aircraft is 18 litter patients or 21 ambulatory patients, or some combination thereof.
- Air crash rescue support.

- Expedient delivery of whole blood, biological, and medical supplies to meet critical requirements.
- Rapid movement of medical personnel and accompanying equipment/supplies to meet the requirements for MASCAL, reinforcement/reconstitution, or emergency situations.
- Movement of patients between hospitals, aeromedical staging facilities, hospital ships, casualty receiving and treatment ships, seaports, and railheads in the brigade AO.

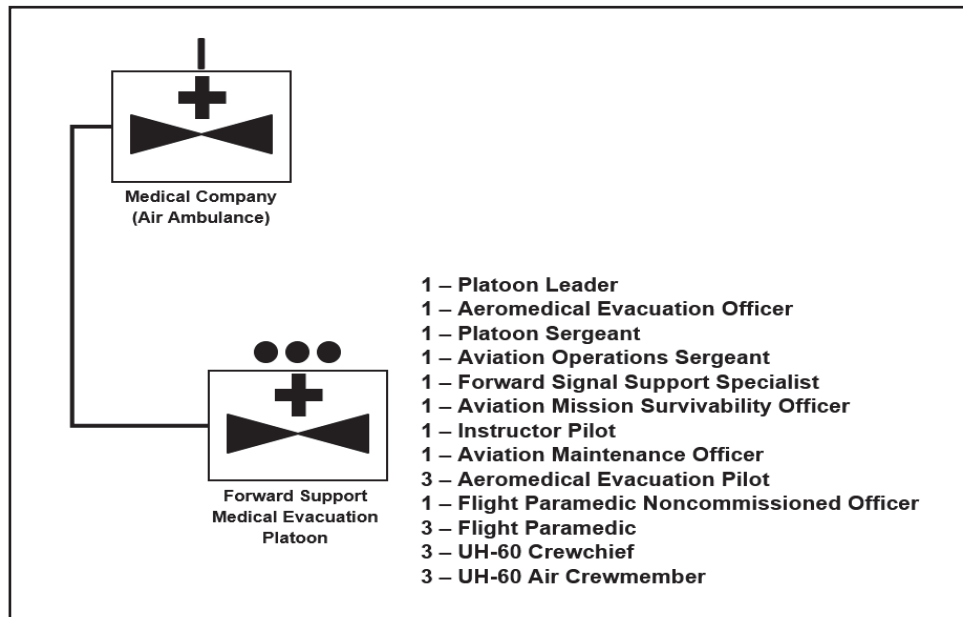

Figure 1-28. Forward support medical evacuation platoon

FORWARD DISTRIBUTION TEAM

1-197. The forward distribution teams (FDTs) will assist customers in their area of responsibility with MEDLOG automated information system, also known as AIS, and provide in-transit visibility. They receive and process Class VIII supplies at strategic air and sea hubs in theater, facilitating medical materiel movement. These teams may also collocate with Role 2 BSMC and the BMSO, if required, and provide distribution management of Class VIII. The medical logistics company (MLC) has three assigned FDTs (see figure 1-29 on page 1-74). This team provides the process of —

- Up to 1.33 short tons of Class VIII per day (per FDT).
- Four short tons of Class VIII supplies per day (all three FDTs).

CONTACT REPAIR TEAM

1-198. The contact repair team (CRT) provides Class VIII support, optical lens fabrication and repair, and medical equipment maintenance and repair for the BCT and

EAB units, to include augmented support to the hospital center. The MLC has three assigned CRTs (see figure 1-29 below). This team provides—

- Provides rapid deployment to support up to 31 man-hours of medical maintenance repair service per day.
- Provides field medical equipment maintenance and repair support to BCT and EAB units.

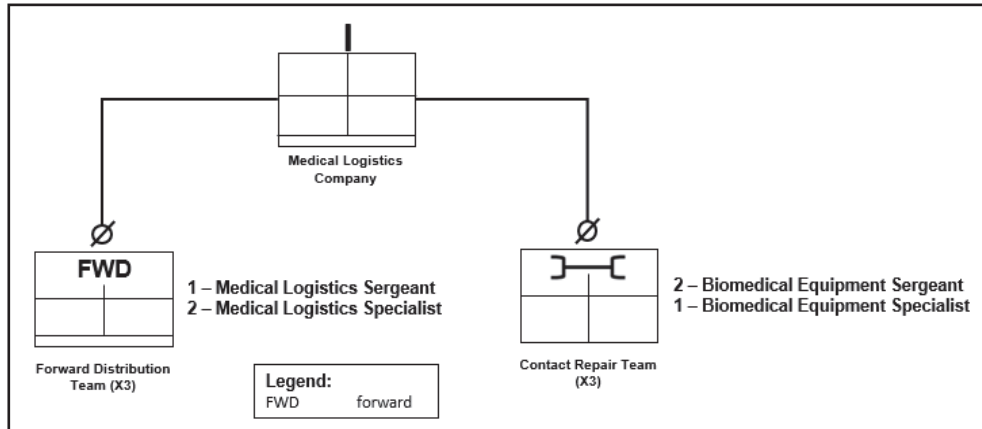

Figure 1-29. Forward distribution and contact repair teams

Chapter 2

Command and Control

Command and control is fundamental to the art and science of warfare. Medical platoons apply command and control to develop the situation in support of the battalion's AHS support mission to treat and evacuate patients. The application of *Troop leading procedures* is a dynamic process used by small-unit leaders to analyze a mission, develop a plan, and prepare for an operations (ADP 5-0). Effective command and control in support of the battalion's AHS support mission is essential to make effective decisions in an uncertain environment.

Contents		
		Page
SECTION I	Platoon Mission Command	2-1
SECTION II	Planning Considerations	2-3
SECTION III	Troop Leading Procedures	2-6
SECTION IV	Military Decision-making Process	2-35
SECTION V	Risk Management	2-49
SECTION VI	Rehearsals	2-51
SECTION VII	Precombat Checks or Precombat Inspections	2-56
SECTION VIII	After Action Review	2-59
SECTION IX	Communications	2-69

SECTION I – PLATOON MISSION COMMAND

2-1. *Mission command* is the Army's approach to command and control that empowers subordinate decision-making and decentralized execution appropriate to the situation (ADP 6-0).

MISSION COMMAND PRINCIPLES

2-2. Medical platoon leader lead consistent with the principles of mission command. This principles are:

- Competence.
- Mutual trust.
- Shared understanding.

- Commander's intent.
- Mission orders.
- Disciplined initiative.
- Risk acceptance.

2-3. Tactically and technically competent commanders, staffs, platoons, and teams are the basis of effective mission command. Leaders within the medical platoon must be technically competent at their jobs and those of their subordinates.

2-4. The medical platoon's complex mission requirements require increased emphasis on teamwork, which may require a longer and more deliberate team-building process than other organizations. There needs to be mutual trust from the lowest ranked combat medic through the platoon leader. Medical platoons often operate with limited communications and minimal guidance stretched over remote distances during which medical platoon personnel must develop certainty from uncertain situations while treating and evacuating patients. The medical platoon mission requires commanders and their staffs; ISGs, platoon leaders, and PSGs to develop trust to operate effectively. They develop this trust during rehearsals, operations, after action reviews (AARs), and counseling sessions. Leaders need to sit with seniors, peers, and subordinates and highlight expectations. Developing trust is consistent with candor. Leaders develop candor with seniors, peers, and subordinates by listening and understanding their points of view. Subordinates must speak out if they see a better solution or violation of doctrine, medical ethics, or safety. If all the above is performed and a leader chooses a different approach or COA the subordinates will feel all the facts were present in decision-making and trust leaders to execute the mission successfully.

2-5. The platoon requires shared understanding of the mission, intent, and commander's medical guidance to accomplish the mission. Understanding the mission two levels up and the mission of the supported unit allows subordinates to focus on mission accomplishment without dwelling on unnecessary detail.

2-6. At the medical platoon level, it is essential for leaders to understand the battalion and HHC commander's focus, commander's intent, purpose of the operation, and commander's medical guidance. This offers platoon leaders both freedom of action as well as direction to allow subordinates to execute and accomplish stated objectives.

2-7. The medical platoon leader, assisted by the PSG, uses TLP for platoon-level preparation, MDMP for battalion-level preparation, and mission orders in order to prepare for missions, issue orders, and employ the platoon. Command and control allows the medical platoon leader to emphasize timely decision-making and clearly identify the tasks for subordinates to execute to achieve the desired end state.

2-8. Medical platoon personnel exercise initiative based on the commander's intent and medical guidance to make informed decisions on possible courses of action. As conditions change, they apply their understanding of that guidance to execute disciplined initiative to meet commander's desired end state.

2-9. By understanding their own and subordinate capabilities and competence, coupled with trust and understanding throughout the medical platoon, leaders can focus on the

commander's intent. They conduct TLP for the platoon, conduct MDMP for the battalion, and rapidly produce mission orders that allow their subordinates' initiative in providing clarity while conducting the battalion's AHS support missions for supported commanders. They rely on all of the above listed elements to accept risk in the unclear environment in which they operate.

IMPORTANCE OF COMMANDER'S INTENT

2-10. It is critical that the platoon leader and subordinate elements clearly understand and execute missions within the commander's intent. Commander's intent describes what constitutes success for the mission including the operation's purpose, key tasks, and the conditions that define the end state. Understanding this intent enables the medical platoon leader to plan AHS support that is synchronized with the scheme of maneuver and flexible enough to adapt to the changing realities on the ground without receiving further orders. Commander's intent must be simple, concise, and easily understood two echelons lower in the chain of command to enable Soldiers to act quickly and decisively in fluid and chaotic situations.

2-11. Maneuver battalion medical platoons may not receive the commander's medical guidance as described in AHS doctrine. They often have to refine commander's intent into guidance for their subordinates to achieve success. The components of commander's intent are expanded purpose, key tasks, and end state. For example, based on critical tactical factors, the commander's intent may be to get to a checkpoint or assembly area without delay to resupply, rest, refuel, or perform other sustainment functions. Therefore, the medical platoon should understand that the treatment and subsequent evacuation of a patient must account for that tactical situation. Medics may have to treat the best they can, load the patient in a ground ambulance, and then provide additional treatment and arrange for evacuation once in the assembly area.

SECTION II – PLANNING CONSIDERATIONS

2-12. Planning is the process by which small-unit leaders translate their visualization of the end state into a specific COA for preparation and execution, focusing on the expected results. Planning involves developing an understanding of the relationship among METT-TC and begins with the analysis and assessment of the current conditions in the OE with particular emphasis on the enemy. It involves understanding and framing the problem and envisioning the set of conditions representing the desired end state. Based on the higher commander's guidance, medical platoon leadership's planning includes formulating one or more suitable COA to accomplish the mission. Planning continues as necessary during preparation and execution. The platoon leader relies on intuitive decision-making and direct contact with subordinate leaders to integrate activities when circumstances are not suited for MDMP or TLP.

PLANNING, EXECUTION, AND ASSESSMENT

2-13. Preparation consists of activities performed by units to improve their ability to execute an operation. Preparation includes, but is not limited to plan refinement, rehearsals, information collection, coordination, inspections, and movement.

2-14. Execution is putting a plan into action by applying combat power to accomplish the mission and using situational understanding to assess progress and make adjustments based on the current tactical situation.

2-15. Assessment refers to the continuous monitoring and evaluation of the current situation, particularly the enemy, and progress of an operation. Assessment precedes and guides every operations process activity and concludes each operation or phase of an operation. It involves a comparison of forecasted outcomes to actual events. Assessment entails three tasks:

- Continuously assessing the enemy's reactions and vulnerabilities.
- Continuously monitoring the situation and progress of the operation towards the leader's desired end state.
- Evaluating the operation against measures of effectiveness and measures of performance.

2-16. Leaders use TLP when working alone or with a small group to solve tactical problems. For example, a platoon leader may use the PSG and SQDLDRs to assist during TLP. The type, amount, and timeliness of information passed from higher to lower directly impact the lower unit leaders TLP. Refer to FM 6-0 for more information.

PARELLEL AND COLLABORATIVE PLANNING

2-17. Parallel and collaborative planning occurs when two or more echelons plan the same operation at about the same time. Parallel, collaborative planning is easiest when the higher unit continuously shares information on future operations with subordinate units. Rather than waiting until battalion and/or company commander finishes planning, the medical platoon leader starts to develop their unit's missions as information is received and fleshes out their missions as more information becomes available.

2-18. Medical platoon leadership starts by identifying the unit's mission's, stating its intent, and ensuring the intent reflects the operational concepts of their higher and second higher command. They choose the tasks most likely to be assigned to the unit and develops mission statements based on the information received. At all levels, developing and describing the vision of leaders requires time, explanation, and ongoing clarification. All leaders understand that their next higher commander's concept of the operation continues to mature and they continue parallel planning as it does so, up until execution. Figure 2-1 illustrates the parallel sequences of the MDMP of a battalion, TLP of a company with TLP of its platoons.

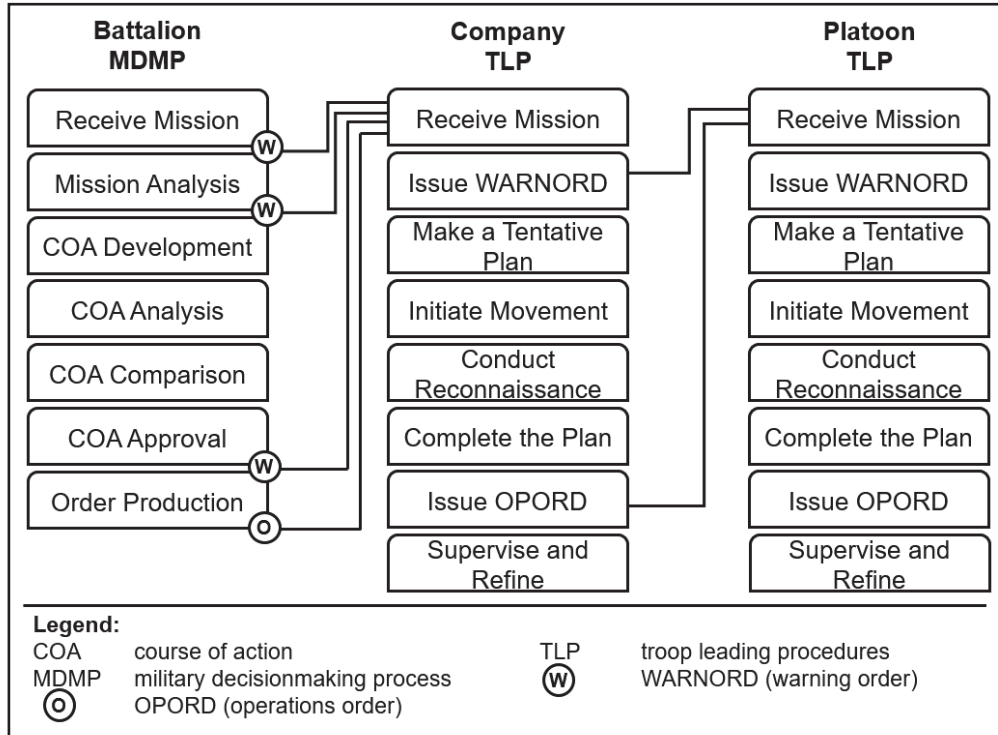

Figure 2-1. Parallel planning

2-19. Normally, the first three steps (receive the mission, issue a WARNORD, and make a tentative plan) of TLP occur in order. However, the sequence of subsequent steps is based on the situation. The tasks involved in some steps, such as initiate movement and conduct reconnaissance, may occur several times. The last step, supervise and refine, occurs throughout.

2-20. A tension exists between executing current operations and planning for future operations. Medical platoon leadership must balance both. If engaged in a current operation, there is less time for TLP. It may be necessary for platoon leadership to determine in advance and designate focus areas by key personnel. For example, the PSG and PA focus on the current operation in order to free up the MEDO for planning. If in a lull, transition, or an assembly area, leaders have more time to use TLP thoroughly. In some situations, time constraints or other factors may prevent leaders from performing each step of TLP as thoroughly as they would like. For example, during the step, make a tentative plan, small-unit leaders often develop only one acceptable COA versus multiple COAs. If time permits, leaders may develop, compare, and analyze several COA before deciding which one to execute.

2-21. The platoon leader begins TLP when they receives the initial WARNORD or receives a new mission. As each subsequent order arrives, they modifies their assessments, updates tentative plans, and continues to supervise and assess preparations.

In some situations the platoon leader may not receive or issue the full sequence of WARNORD; security considerations or tempo may make it impractical. Leaders carefully consider decisions to eliminate WARNORD. Subordinates always need to have enough information to plan and prepare for their mission. In other cases, TLP are started before receiving a WARNORD based on existing plans and orders (contingency plans or be-prepared missions) and on a subordinate leader's understanding of the situation.

2-22. Parallel planning hinges on distributing information as it is received or developed. Subordinate leaders cannot complete their plans until they receive their unit mission. If each successive WARNORD contains enough information, the higher command's final order will confirm what subordinate leaders have already analyzed and put into their tentative plans. In other cases, the higher command's order may change or modify the subordinates' tasks enough that additional planning and reconnaissance are required.

SECTION III – TROOP LEADING PROCEDURES

2-23. *Troop leading procedures* is the dynamic process used by small-unit leaders to analyze a mission, develop a plan, and prepare for an operations (ADP 5-0). The commander makes most tactical decisions. They then announces them in the form of orders that include their intent and concept of the operation. Based on these orders, the medical platoon leader uses TLP to organize their time during planning and preparation and to translate the operation into instructions their Soldiers can understand. The platoon leader can then lead the platoon more effectively in the execution of the mission.

2-24. Troop leading is a dynamic process that becomes the most frequently used tool in mission preparation. It begins when the unit receives a new mission or is notified by a WARNORD that a new mission is imminent. Whenever possible, TLP are integrated and accomplished concurrently rather than sequentially. Time management is the key. The medical platoon leader normally uses one-third of the available time to plan, prepare, and issue the order; the PSG, ambulance SQDLDRs, and treatment TLs then have the remaining two-thirds of the time available to prepare the BAS, ambulance teams, and equipment to support the operation. Parallel planning will aid the medical platoon in accomplishing its mission. Even if the platoon leader does not have a complete plan, issuing guidance early allows more time for rehearsals which are essential to any successful operation, particularly in the medical platoon. The treatment squad, ambulance squad, and combat medic section often operate dispersed and over extended distances and the squad and TLs require time to conduct their planning and issue orders and guidance to their Soldiers.

2-25. The following discussion focuses on the eight steps of TLP:

- Receive the mission.
- Issue a WARNORD.
- Make a tentative plan.
- Initiate movement.
- Conduct reconnaissance.
- Complete the plan.

- Issue the order.
- Supervise and refine the plan.

Note. The sequence of the steps of TLP is not rigid. Leaders modify them as required. Higher headquarters issue frequent WARNORDs to optimize available time for subordinates to conduct their TLP.

2-26. Planning in the medical platoon is always a time-constrained event. Medical platoons are routinely required to execute their mission shortly after the higher headquarters' mission analysis and order are published. This means the medical platoon often executes their mission with an immature understanding of the situation, specifically as it relates to enemy, terrain, and civilians. To help subordinates operate more confidently in these ambiguous conditions, all levels of leadership within the medical platoon should be trained in TLP and reverse planning.

2-27. All planning is reverse planned from LTIOV. It may be useful for the platoon leader to develop a detailed planning timeline and standardize it in an SOP to help them manage their own time during the planning process.

2-28. The platoon leader ensures that all subordinates have sufficient time for their own planning and preparation needs. Generally, the platoon leader uses no more than one-third of the available time for planning and issuing the OPORD. The platoon leader allocates the remaining two-thirds of it to subordinates. Figure 2-2 illustrates a possible timeline for a medical platoon. The platoon adjusts the tentative schedule as necessary.

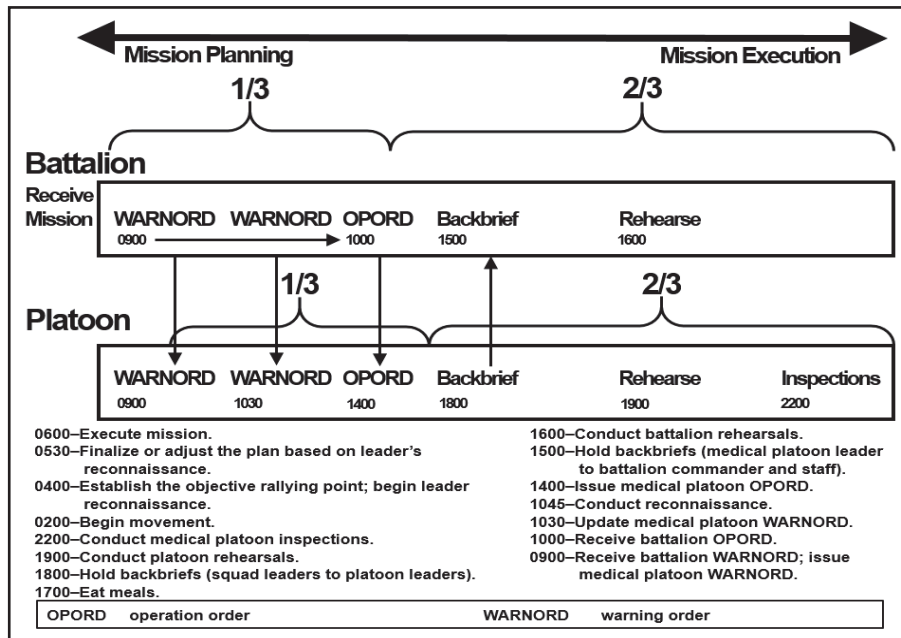

Figure 2-2. Sample planning timeline

2-29. When a medical platoon is augmented (BSMC ambulances or a BSMC treatment team), these attachments should be included in the planning process as early as possible to ensure that METT-TC considerations relevant to their mission sets are addressed. The equipment and time requirements of attachments to execute their support tasks and the additional terrain considerations of these operations may significantly impact the mission planning of a medical operation.

2-30. Medical platoons plan to be decentralized in many circumstances. The medical platoon may split the BAS during the first phase of a mission and have to plan the next phase while executing split BAS tasks. Often, time and distance will not permit gathering the entire medical platoon around a terrain board for an OPORD. Leaders must become adept at overcoming the distance separating the medical platoon from other supported maneuver elements. Possible solutions include:

- Practice the use of digital communication systems to distribute graphics and orders.
- Require all leaders to monitor the company/battalion frequency while the commander issues the OPORD to the platoon leader.
- Require all personnel to observe listening silence while orders are issued on the frequency.
- Predetermine runners from platoon leader/PSG vehicle to communicate complex information between vehicles.
- Designate personnel from each squad to prepare copies of analog graphics or personnel from platoon leader/PSG vehicles.
- Ensure everyone, not just the platoon leader, has standardized operating graphics before missions. Graphics include, at a minimum, boundaries, phase lines, checkpoints, CCPs, AXPs, named areas of interest, and target area of interest.
- Require squad and TLs to move to the platoon leader's location one or more at a time to receive information not easily understood verbally or the platoon leader moves to section leader to brief information. This may be accomplished when the company ISGs come to the combat trains for resupply.
- Standardize formats in the tactical SOP for conveying complex information such as information requirements.

STEP 1 – RECEIVE THE MISSION

2-31. The medical platoon is a battalion-level direct support asset. The platoon receives its mission from the battalion commander. It is the platoon leader's responsibility to have a complete understanding of the mission and the commander's intent including implied tasks not explicitly stated. The platoon leader should ask questions when they are unsure, and develop requests for information to gain as much information as possible. Requests for information may not be answered in a timely manner or at all, and the platoon leader will operate off assumptions.

2-32. If the situation allows, the platoon leader should bring their PSG, treatment SQDLDR, and as many ambulance TLs as possible when they receive the mission from

the commander. Consider including the company senior medics when platoon leadership goes to receive the mission, METT-TC dependent. Multiple platoon representatives at the briefing may save time and assist the understanding of subordinate leaders without diluting information. At the receipt of the mission the platoon leader must—

- Understand the enemy, friendly, and civilian situation.
- Understand the commander's intent, tasks (key, specific, and implied), end state, commander's AHS support guidance and CCIRs.
- Understand the AHS support objective.
- Understand how the platoon plan fits into the higher headquarters' plan.
- Know any attached assets and how to coordinate with them.
- Copy all common graphics available including graphic control measures, scheme of maneuver, support, fires, information collection, air, enemy situation. A member of the platoon leader's crew should copy graphics so the platoon leader has more time to understand and plan the mission.
- Copy planning and execution timeline. Pay close attention to critical times specified by higher.

2-33. The medical platoon leader's first task is to extract the AHS support mission based on the battalion commander's guidance and intent. The key to understanding the medical platoon AHS support mission, as part of the battalion team, lies in two elements of the plan—the commander's intent and the purpose they envision for the battalion, each company, and each direct support platoon.

2-34. The medical platoon leader's knowledge of the intent and purpose allows him to use their initiative and to be proactive and exploit battlefield opportunities to accomplish the AHS support mission. If the medical platoon leader does not understand the intent or purpose, they should ask the commander for clarification.

2-35. The medical platoon leader analyzes the mission using the factors of METT-TC. These factors allow the platoon leader to identify the platoon's purpose; the specified, implied, and essential tasks it must perform; and the timeline by which the platoon will accomplish those tasks. The following outline of METT-TC factors will assist the medical platoon leader in analyzing the mission and creating a timeline.

MISSION

2-36. A way to help analyze the mission is to answer and understand questions and information such as the following:

- What is the battalion commander's intent?
- What are the current capabilities (organic and attached assets with current status and locations)?
- What are the specified, implied, and essential AHS support tasks in the battalion and brigade OPORD?
- What are the limitations (AHS support assets that are not available, specify reason)?

- What other tasks must be accomplished to ensure mission success (implied tasks)? Implied tasks are those that are not specified in the OPORD but that must be done to complete the mission. They do not include tasks that are covered in the unit SOP. The medical platoon leader identifies implied tasks by analyzing the enemy, the terrain, friendly troops available, and the operational graphics.
- What is the current patient status (for example, awaiting evacuation)?
- Are patient evacuation vehicles required to use contaminated routes?
- Are patient decontamination stations required?
- Where are the locations of the treatment team and/or medical section of the BAS or other Role 2 medical units providing area medical support? (current/projected?)
- What are the area medical support responsibilities?

ENEMY

2-37. The platoon leader may try to answer some questions during their analysis to help understand the threat. Questions may include—

- What have been the enemy's recent activities?
- What is the composition of the enemy's forces?
- What are the capabilities of their weapons?
- What is the location of current and probable enemy positions?
- What is the enemy's most probable COA?
- What is the enemy's most dangerous COA?

2-38. Enemy information is included in paragraph 1 of the OPORD. It is important that the medical platoon leader analyze this information in terms of how the medical platoon supports the operation. For example, the threat the enemy imposes on the battalion will influence how AHS support operations are conducted based on the projected number of casualties the enemy will inflict on the battalion.

TERRAIN (AND WEATHER)

2-39. The medical platoon leader analyzes the terrain using the factors of observation and fields of fire, avenues of approach, key terrain, obstacles, and cover and concealment (military aspects of terrain) (OAKOC). Elements of this analysis are discussed below.

Observations and Fields of Fire

2-40. The platoon leader may try to answer some OAKOC questions during their analysis. Questions may include—

- Are these influenced by the key terrain that dominates avenues of approach and how will this effect medical treatment and evacuation?
- Where can the enemy observe and engage battalion personnel (danger areas)?

- Where are the natural firing positions that medical platoon personnel can use to defend against enemy attack?

Avenues of Approach

2-41. The platoon leader may try to answer some OAKOC questions during their analysis. Questions may include—

- Where are the best avenues of approach (mounted and dismounted) for friendly and enemy forces?
- These are considerations for determining evacuation routes and in planning for future locations for the BAS.

Key Terrain

2-42. The platoon leader may try to answer some OAKOC questions during their analysis. Questions may include—

- Where is the key terrain? Will FM communications be affected?
- How can key terrain be used to support medical treatment and evacuation?

Obstacles

2-43. The platoon leader may try to answer some OAKOC questions during their analysis. Questions may include—

- Where are natural and existing obstacles located, and how can they affect medical treatment and evacuation?
- Where are likely areas for enemy-emplaced obstacles, and how can they affect maneuver?

Cover and Concealment

2-44. The platoon leader may try to answer some OAKOC questions during their analysis. Questions may include—

- What routes within the AO offer cover and concealment for placement of the BAS, a treatment team, and ambulances?
- Do the natural firing positions in the AO offer cover and concealment for the platoon or enemy?

WEATHER

2-45. The medical platoon leader can use these questions as they analyze the impact of weather on the mission:

- What are the light conditions (including percentage of night illumination) and visibility?
- What are the times for beginning of morning nautical twilight (also referred to as BMNT), sunrise, sunset, end of evening nautical twilight (also referred to as EENT), moonrise, and moonset?
- How has recent weather affected the AO?
- How will this impact treatment and evacuation?

- How will fog, rain, dust, heat, snow, wind, or blowing sand affect the men and equipment during the mission?

Note. The effects of weather on smoke or CBRN weapons/operations should also be

TROOPS

2-46. The medical platoon leader can use these questions as they analyze the impact of troops on the mission:

- What is the supply status of ammunition, fuel, and other necessary items including Class VIII?
- What is the present physical condition of the Soldiers, as well as of vehicles and equipment?
- What is the training status of the platoon?
- What is the state of morale?
- How much sleep has the platoon had?
- How much sleep will they be able to get before the operation begins?
- Does the platoon need any additional assets to support or accomplish its mission?
- What attachments are available to help the platoon accomplish its mission?
- What is the TASKORG in the WARNORD or OPORD?

TIME AVAILABLE

2-47. The medical platoon leader can use these questions as they analyze the impact of time on the mission:

- What times were specified by the commander in the OPORD for such activities as movement, reconnaissance, rehearsals, and logistics package (LOGPAC) operations?
- What priorities of work can the platoon accomplish (examples include security, maintenance, resupply, coordination, rehearsals, inspections, and sleep)?

Note. The medical platoon leader conducts reverse planning to ensure that all specified, implied, and essential tasks can be accomplished in the time available. They develop a reverse planning schedule (timeline) beginning with actions on the objective and working backward through each step of the operation and preparation to the present time. This process also helps the platoon in making efficient use of planning and preparation time. Once the METT-TC analysis is complete, the medical platoon leader can write the platoon mission statement based on the battalion AHS support plan and answer the questions of WHO, WHAT, WHEN, WHERE, and WHY. This is a clear, concise statement of the purpose of the operation and the essential task(s) that will be crucial to its success. The essential tasks (the WHAT) should be stated in terms that relate to enemy forces, friendly forces, and/or the terrain (for example, “ESTABLISH BAS (-) ONE OR TWO TERRAIN FEATURES FROM THE MAIN BATTLE AREA”; “ESTABLISH THE BAS 1 TO 3 KILOMETERS FROM THE MAIN BATTLE AREA”; or “BE PREPARED FOR RAPID FORWARD DEPLOYMENT OF A MEDICAL TREATMENT SECTION IN SUPPORT OF COMPANY A.”) The purpose (the WHY) explains how the platoon mission supports the commander’s intent. The elements of WHO, WHERE, and WHEN add clarity to the mission statement.

Note. Simultaneous planning and preparation are key factors in effective time management during TLP. The next five steps (issue a WARNORD; make a tentative plan; initiate movement; conduct reconnaissance; and complete the plan) may occur simultaneously and/or in a different order. There may be multiple WARNORD.

2-48. The medical platoon leader should be prepared to conduct a confirmation brief usually within 20 minutes of receiving the order or as time demands, so the commander knows that the platoon leader understands the mission, commander’s intent, CCIR, and the purpose of conducting the mission. The commander may require a confirmation brief immediately following the mission brief. Platoon leaders bring up shortfalls that they identified on their initial assessment of the mission. If the platoon leader identifies a shortfall, they generate a possible solution to present to the commander.

2-49. The confirmation brief will not hinder the issuance of the WARNORD to the platoon. The PSG may issue the WARNORD if the platoon leader is conducting a confirmation brief.

2-50. While the platoon leader receives the mission from the commanding officer, the rest of the platoon executes tasks to prepare for the mission. Regardless of the platoon’s mission, completing the tasks listed below allow increased planning time.

2-51. The PSG alerts the platoon that the platoon leader is receiving a mission, gathers supply requests from subordinate leaders, and consolidates the sensitive items report. Additionally, they will create or update the battle roster, maintain accountability of

weapons and equipment, create or update the sensitive items list, and supervise the cross loading of classes of supplies.

2-52. Squad and TLs consolidate supply requests, perform PCCs of equipment, submit the sensitive items report, improve camouflage, and supervise equipment maintenance. Additionally, the medical platoon rehearses battle drills or tasks from the unit TACSOP that generally do not change and are common to all operations like MEDEVAC and establishing the BAS. The time for rehearsals during the rest of the planning process will generally center on supporting actions on the objective and critical points in the operation or the entire operation itself.

2-53. The medical platoon conducts before or during preventive maintenance checks and services (PMCS) of individual equipment and vehicles, improves individual, equipment, and vehicle camouflage, inventories all equipment, resupplies classes of supply (especially Class VIII), and informs their leader when complete.

STEP 2 – ISSUE A WARNING ORDER

2-54. The platoon leader with the help of the PSG finishes the initial assessment of the situation and available time. They do not wait for more information, and issue the best and most detailed WARNORD possible. A WARNORD is a preliminary notice of an order or action that is to follow (JP 5-0). The more time subordinates have to prepare and conduct rehearsals, the better. The platoon leader will issue additional WARNORDs as more information becomes available or the situation changes.

Note. The medical platoon leader will often do this from the battalion command post during mission analysis.

2-55. The platoon leader conducts more analysis of the WARNORD received from the battalion commander prior to issuing to the platoon. For example, the timeline the platoon leader received may include details for the troop, but not adequately address times for section rehearsals. The execution timeline may change slightly during TLP, both the platoon leader and PSG understand the platoon's capabilities and limitations and apply sound judgment to estimate the time required. Use of a platoon standardized timeline format will assist medical platoon personnel in planning and execution.

2-56. The platoon leader will issue the first WARNORD usually within 30 minutes of the completion of receiving the mission, or as time demands. The WARNORD has no specified format, though it may follow the five-paragraph OPORD format. The minimum requirements for a WARNORD should be:

- I. Situation.
 - Area of interest.
 - Area of operations.
 - Enemy forces.
 - Friendly forces.
 - Interagency, intergovernmental, and nongovernmental organizations.

- Civil considerations.
- Attachments and detachments.
- II. Mission.
- III. Execution.
 - Initial commander's intent.
 - Concept of operations.
 - Tasks to subordinate units. (This will include the AHS support mission.)
 - Coordinating instructions. (This will include specified tasks the medical platoon must perform.)
- IV. Sustainment.
- V. Command Signal. Additional things that a medical platoon leader adds to a WARNORD are—
 - Directed changes to TASKORG.
 - Key tasks and end state.
 - Restated mission statement (if analysis was not done at battalion level, restated mission must be approved by battalion commander).
 - Specified tasks to subordinates (to include service support instructions).
 - Commander's AHS support guidance.
 - Commander's critical information requirement.
 - A copy of all common graphics available including graphic control measures, scheme of maneuver, support, fires, information collection, air, and enemy situation.
 - Specific tasks and rehearsals and who is responsible for their completion.
 - A tentative/refined platoon timeline that includes the following:
 - Earliest time of movement.
 - Readiness condition and vehicle preparation schedule.
 - Reconnaissance.
 - Training/rehearsal schedule.
 - Time and place of the OPORD.

Note. The medical platoon leader may initiate some individual and collective training before they issue the OPORD; this technique maximizes preparation time and allows the platoon to focus on tasks that will support the anticipated operations. For example, a medical platoon may train on treatment of different types of wounds or injuries that may be seen during the operations.

2-57. It is helpful to have a member of each squad and team designated to copy graphics allowing leaders more time to plan.

2-58. As critical information is received or updated, the medical platoon leader should issue subsequent or updated WARNORD to keep the platoon informed.

STEP 3 – MAKE A TENTATIVE PLAN

2-59. The medical platoon leader begins developing their AHS support plan when the battalion receives its first WARNORD from the brigade. Based on the commander’s intent, guidance, and the results of their mission analysis, the medical platoon leader develops a tentative plan that addresses all specified, implied, and essential tasks using the OPORD format. The tentative plan also covers reconnaissance and coordination requirements between the platoon and adjacent and supporting units. The medical PSG, PA, and field surgeon are excellent sources of ideas concerning the battalion AHS support plan and the platoon leaders should seek out their advice. The medical platoon leader can develop their COA and OPORD almost simultaneously with the battalion OPORD. Since the medical platoon is a battalion asset, most of their specified tasks will be developed during the battalion MDMP. The medical platoon leader can issue a WARNORD from the battalion command post during their participation in the MDMP. By the time the OPORD is given, they should have most of their platoon order prepared. The development of the platoon timeline from reverse planning should be their priority as soon as the battalion OPORD is prepared.

2-60. The platoon leader must complete the mission analysis prior to the scheme of maneuver. Subordinates cannot make simple, flexible plans against a thinking enemy if they do not understand what the enemy is doing. Also, all analysis is subject to change with time, and as more intelligence becomes available. Terrain and enemy analysis is constantly updated before, during, and after operations.

2-61. The medical platoon leadership uses METT-TC as way to help understand the aspects of the mission and how they affects operations. It may help to think of METT-TC as a synchronized (sync) matrix throughout operations. Sync matrixes (see table 2-1) help the leader understand they must accomplish their mission in time, and with proper terrain analysis, and space.

Table 2-1. Example, hasty synch matrix

<i>Time</i>	0900	0930	1000	1030	1100	1130	1200	1230	1300
<i>Enemy</i>	Attack on city court house				Withdrawal		Consolidate vicinity Hill 431		
<i>Civilians</i>	Civilians running in all directions from court house						Medical services in AO		
<i>The Higher Headquarters' Mission</i>	Phase II: Defense of AO Bastogne								
<i>Platoon Mission</i>	Phase III: Provide medical treatment and evacuation				Phase IV: Prepare to support counterattack of Hill 431				
<i>Attachments/2x M997 from BSMC</i>		En route to BSA		En route to BAS		En route to BSA		En route to BAS	
Legend:									
AO area of operation			BSA brigade support area						
BAS battalion aid station			BSMC brigade support medical company						

2-62. Analysis of METT-TC and OAKOC does not need to be in a particular order. The order follows the preference of the leader and the experience they have analyzing a mission. Some leaders may evaluate in the order of terrain and weather, enemy, civil considerations, time, mission and finally troops and support available.

MISSION

2-63. Medical platoon personnel must understand the mission and commander's intent, medical guidance, and the CCIRs. Leaders at all levels understand how their plan nests with the higher headquarters and what information higher headquarters needs to aid the commander in making an informed decision. Understanding what indicators link to commanders' decisions aids subordinate leaders in taking disciplined initiative. It is impossible to predict the outcome of every engagement. However, an understanding of what the higher commander needs to know, and why, will aid leaders in adapting the current plan to meet the requirements of the commander.

2-64. A way to help analyze the mission is to answer and understand questions and information such as the following:

- What is the higher headquarters' mission, intent, end state, and CCIR two levels up?
- What is the unit's purpose?
- What have Soldiers been told to do, and why?
- What tasks did the commander say must be accomplished (specified tasks)?
- What other tasks must be accomplished to conduct the mission (implied tasks)?
- Based on the commander's intent, which medical platoon tasks are absolutely essential?
- How does the commander's medical guidance fit into the higher headquarters' plan?
- What is the composition and disposition of the enemy the unit is expected to encounter?

2-65. The medical platoon faces an elusive, diverse, flexible, and adaptive enemy. The enemy combines a wide array of lethal and nonlethal weapons, including modern peer, near-peer, hybrid threats, and improvised systems presenting a complex enemy situation. In order to medically support the battalion, the platoon must consider the wide-ranging capabilities the enemy may use as a form of contact. The forms of contact to consider are—

- Direct fire.
- Indirect fire.
- Nonhostile civilian contact.
- Obstacles.
- Chemical, biological, radiological, and nuclear.
- Aerial.
- Visual.

- Electronic warfare.

ENEMY

2-66. The medical platoon must understand the enemy's objective, and depict the enemy in their AO down to the squad and team level. Breaking the enemy two levels down gives the platoon's subordinate leaders a better understanding of enemy capabilities and how to address these capabilities in the friendly plan. Successful enemy analysis allows the platoon leader to visualize when and where to anticipate contact and have medical assets available to support.

2-67. The medical platoon leadership may try to answer some questions during their analysis to help understand the threat. Questions may include—

- What is the composition, disposition, and strength of the enemy force?
- What are the capabilities of their weapon and surveillance systems?
- Where are their kill zones?
- What is the enemy trying to do (defend, reinforce, attack, withdraw, or delay)?
- What will they do in response to friendly actions?

2-68. The battalion staff may provide products and information on the enemy. Leaders must be flexible with enemy estimates and adjust to what they are facing especially if it differs from what they predicted. Platoon leadership tries to answer or understand the following and articulate its findings to subordinates:

- Enemy's composition, disposition, and strength.
- Enemy's objectives one and two levels up.
- Enemy's weapon systems and optics capabilities.
- Enemy's equipment (uniform color/pattern, equipment carried on their person).
- Vehicle composition, vehicle appearance, configuration and formations (how many are there? If I see one, how far away are the others?).
- Enemy activity in relation to their mission.
- Historical and doctrinal reference of how the enemy fights.
- Recent experience with how the enemy fights.
- Order of battle.
- Forms of contact the enemy prefers to gain contact with the platoon and forms of contact the enemy may avoid.
- Enemy's engagement, disengagement, and displace criteria.

2-69. Understanding the above information will aid platoon leadership with planning and preparing for anticipated threats. Failing to understand the enemy or shortchanging the enemy in the assessment generally leads to failure.

2-70. Platoon leadership receives a most likely COA and a most dangerous COA from the battalion commander. Some circumstances and time constraints may warrant only receiving a most likely COA and planning based on that. The troop commander

specifies when this circumstance is happening and informs the platoon leader. In all other cases, the platoon leader plans off the most likely COA and most dangerous COA.

2-71. Generally, the enemy COAs are unit symbols that are platoon- or section-sized elements. It is the platoon leaders' responsibilities to take the information they gain and refine the enemy COAs down to squad and team level. It may help to depict sectors of fire and limits of weapon systems for all anticipated forms of contact to aid themselves and subordinate leaders in understanding the threat and planning against it (see figure 2-3).

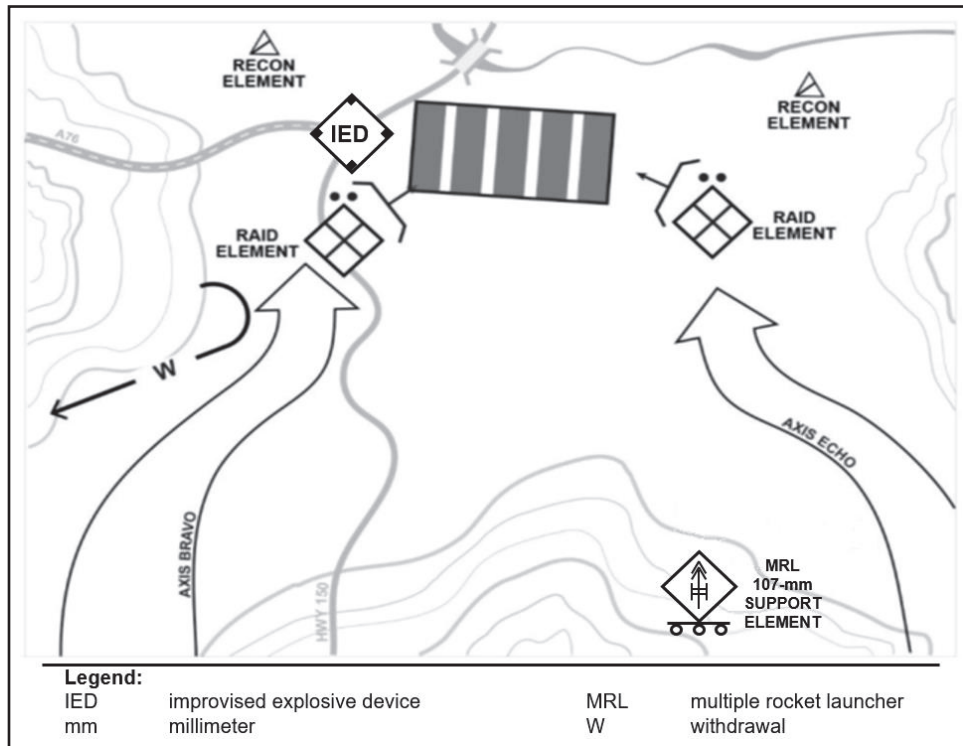

Figure 2-3. Enemy course of action

TERRAIN AND WEATHER

2-72. Leaders must thoroughly know and understand the terrain and weather in their AO. Overlooking minute details or false assumptions during planning on seemingly unpassable terrain or effects of weather involving streams, fords, and narrow defiles have historically lead to disaster.

Terrain

2-73. Leaders consider how the terrain will affect the friendly and enemy force's mission. Medical platoon personnel conduct terrain analysis using OAKOC. In general, terrain and weather do not favor one side over the other unless one is better prepared to

operate in the environment or is more familiar with it. The terrain however, may impact where a BAS can be set-up or impact routes for MEDEVAC. A detailed analysis of terrain answers the question —what is the terrain’s effect on the operation?

2-74. While OAKOC is an easily remembered acronym to use for analysis, the results are briefed in an order based on local guidance. Another way of thinking about it is that obstacles indicate avenues of approach dominated by key terrain dictating observation and fields of fire and defining cover and concealment.

2-75. An obstacle is any natural or man-made obstruction designed or employed to disrupt, fix, turn, or block the movement of an opposing force, and to impose additional losses in personnel, time, and equipment on the opposing force. It is important to take into account obstacle effects. For example, rubble and debris in a street may halt ambulance movement, but only slow a dismounted medic. Understand obstacles from the friendly and/or enemy perspective to be successful.

2-76. Avenues of approach are air or ground routes used by an attacking force leading to its objective or to key terrain in its path. The identification of avenues of approach is important because all COAs that involve maneuver depend on available avenues of approach. *Mobility corridors* are areas relatively free of obstacles where a force will be canalized due to terrain restrictions allowing military forces to capitalize on the principles of mass and speed (JP 2-01.3). Identifying mobility corridors requires some knowledge of friendly and enemy forces and their preferred tactics. The best mobility corridors use unrestricted terrain that provide enough space for a force to move in its preferred doctrinal formations while avoiding major obstacles.

2-77. Avenues of approach consist of a series of mobility corridors through which a maneuvering force must pass to reach its objective (see table 2-2). Avenues of approach must provide ease of movement and enough width for dispersion of a force large enough to significantly affect the outcome of the operation. Mobility corridors should be classified based on the distance between the terrain features that form the corridor. Avenues of approach can assist the medical platoon in determining where to place medical assets.

2-78. Prioritize avenues of approach based on how well each supports the ability to meet the desired result in a timely and efficient manner. Avenues of approach are evaluated for suitability in terms of—

- Access to key terrain and adjacent avenues.
- Degree of canalization and ease of movement.
- Sustainability (line of communications support).
- Access to the objective.

2-79. *Key terrain* is an identifiable characteristic whose seizure or retention affords a marked advantage to either combatant (ADP 3-90). In natural terrain dominated by restrictive terrain features, high ground can be key terrain because it dominates an area with good observation and fields of fire. In an open or arid environment, a draw or wadi can be key terrain because it offers good cover and concealment for establishing the BAS. In urban environments, key terrain may be infrastructure (such as bridges, medical

facilities, choke points, intersections, industrial complexes, and economic, social, and government institutions).

Table 2-2. Avenue of approach to mobility corridor comparison examples

<i>Avenue of approach</i>	<i>Cross-country mobility corridor classification</i>	<i>Approximate distance between terrain features (in kilometers)</i>
Division	Brigade/Regiment	10 (6.2 miles)
Brigade/Regiment	Brigade/Regiment	6 (3.7 miles)
Battalion	Company	2 (1.2 miles)

2-80. Evaluate key terrain by assessing the impact of controlling it for either force. *Observation* is the condition of weather and terrain that permits a force to see the friendly, enemy, and neutral personnel and systems, and key aspects of the environment. (FM 1-02.1). Commanders evaluate their observation capabilities for electronic and optical line-of-sight surveillance systems, as well as for unaided visual observation. Terrain features and low areas normally provides the best cover and concealment. In natural terrain, there are limitations on observation caused by relative, localized, and often subtle variations in terrain elevations and include limitations to observation caused by adverse weather, dusk, and smoke. In urban terrain, observation is primarily limited by man-made structures, as well as the activity and debris associated with human activity. Analyzing observation and fields of fire in urban terrain is more complicated than it is for natural terrain.

2-81. A *field of fire* is an area that a weapon or group of weapons may cover effectively from a given position (FM 3-90-1). A unit's field of fire is directly related to its ability to observe.

2-82. Evaluation of observation and fields of fire identifies—

- Potential engagement areas.
- Defensible terrain.
- Specific equipment or equipment positions.
- Areas where forces are most vulnerable to observation and fires.
- Identification of visual dead space.

2-83. Analysis of a field of fire includes an evaluation of all direct and indirect fire weapons systems in a command's inventory. An ideal field of fire for a direct fire weapon is an open area in which the enemy can be seen and on which the enemy has no protection out to the maximum effective range of that weapon. An ideal field of fire for an indirect fire weapons system is a target area that provides no protection from the system's munitions. A terrain that offers good observation and fields of fire generally favors defensive COAs.

2-84. *Cover* is the protection from the effects of fires (FM 3-96). This includes bullets, fragments of exploding rounds, flame, nuclear effects, and biological and chemical agents. Cover and concealment is available by ditches, caves, riverbanks, folds in the ground, shell craters, buildings, walls, and embankments. Cover does not necessarily

provide concealment. An example of cover without concealment is a bunker in plain sight that is intended for the protection of personnel.

2-85. *Concealment* is protection from observation or surveillance (FM 3-96). It degrades the enemy's ability to observe forces, equipment, or position. Concealment is available in tall grass, trees, underbrush, cultivated vegetation, weather conditions (such as snow, fog, or rain), and man-made camouflage. Concealment does not necessarily provide cover.

2-86. A line-of-sight analysis determines the observation, fields of fire, and cover and concealment that the terrain provides to both friendly and enemy or adversary forces. Figure 2-4 shows the masked area that lies behind terrain that is level with or higher than the defensive position. This is important to the medical platoon leadership as it helps determine placement of the Role 1 BAS and establishment of MEDEVAC routes. However, masked areas provide the attacker cover from the defender's direct fire and concealment from the defender's observations. If the enemy or adversary has done proper analysis, then they would select one or more of the approach routes.

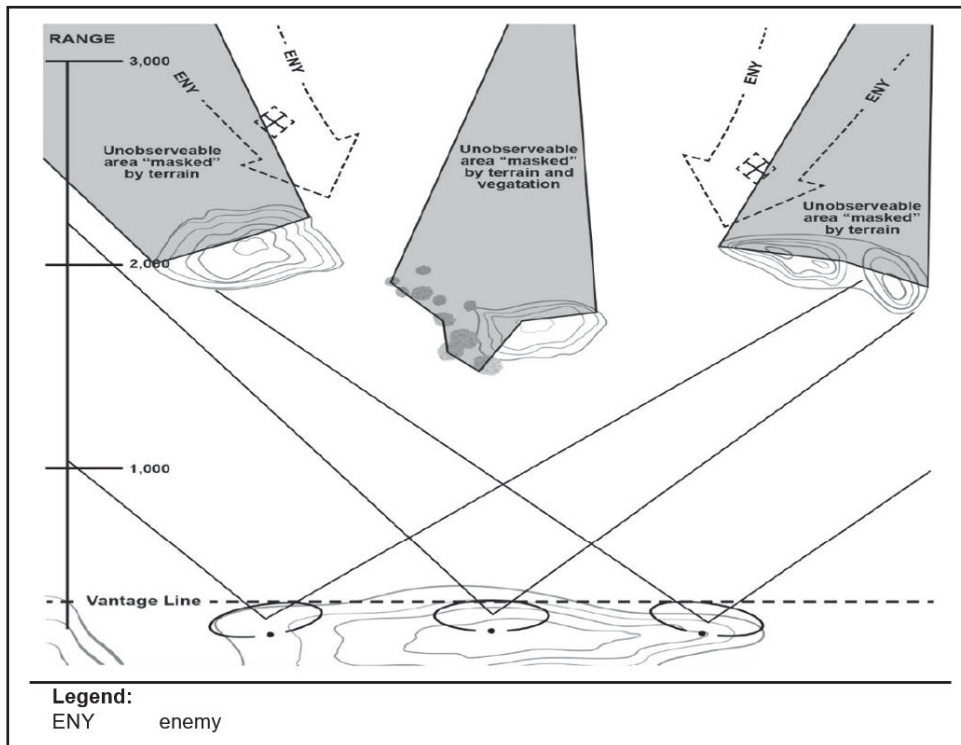

Figure 2-4. Line of sight analysis

more than one type of organization (for example, mounted or dismounted), obstacle overlays reflect an impact on the mobility of a particular force. The overlay depicts areas that impede movement (severely restricted and restricted areas) and areas where friendly and enemy forces can move unimpeded (unrestricted areas).

2-91. The end result of producing a MCOO, either detailed or simplified, is that medical platoon leaders understand the terrain in which they are operating. The MCOO may also help them understand limits in line of sight communications systems. Figure 2-5 is an example of a MCOO.

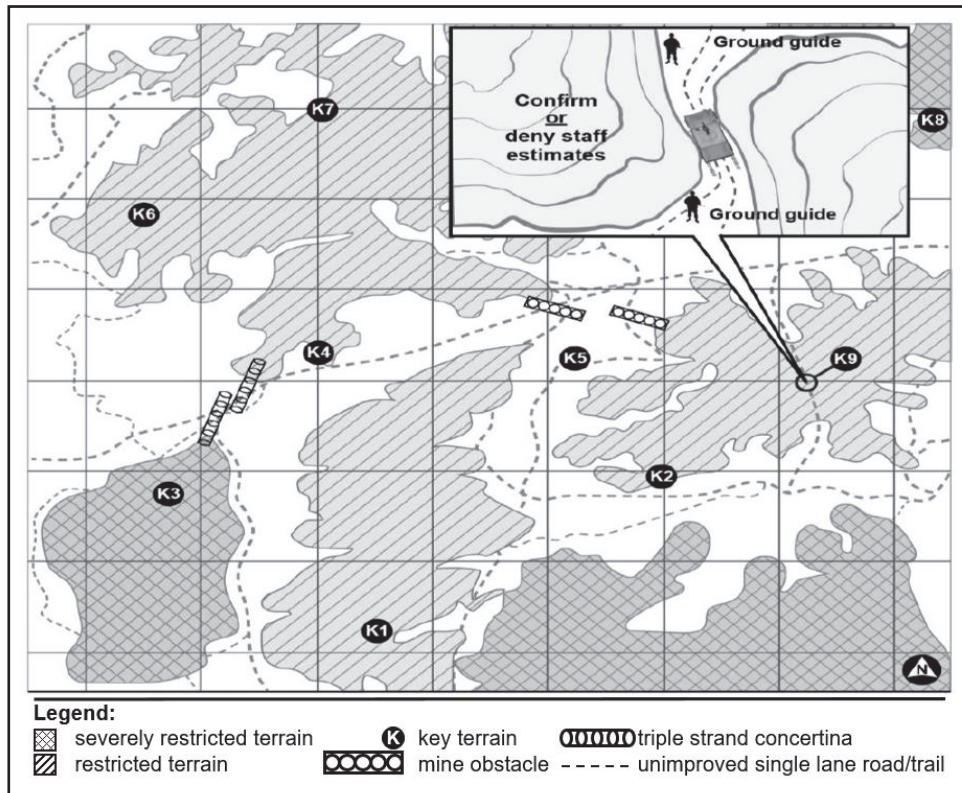

Figure 2-5. Modified combined obstacle overlay, example

2-92. A MCOO is simply a way to help leaders understand their AO. During planning, platoon leaders need to evaluate the terrain using the five elements of military terrain analysis (OAKOC). During security tasks, they evaluate the enemy’s capability to maneuver and during reconnaissance tasks, they consider friendly vehicle capabilities.

Weather

2-93. The five military aspects of weather are visibility, winds, precipitation, cloud cover, and temperature and humidity. Like terrain, it is important to determine how weather affects the mission. Thoroughly understanding of weather impacts is vital to

mission accomplishment. Simply stating it will be windy will not suffice. Explaining the wind direction and effects on smoke targets, the use of aviation or unmanned aircraft system, dust trails or smell helps subordinates understand why the analysis matters. Additionally, the map cannot show that it is raining, but will give indicators of which creeks may flood and become difficult to cross. A general understanding of weather patterns before deployment into an area will aid leaders in planning and understanding time requirements during operations. Table 2-4 is a way to help leaders understand the effects of weather on their operation.

Table 2-4. Example effects of weather matrix

	<i>Data</i>			<i>Effects and who it favors</i>		
Visibility	10 miles.			Neither		
Wind	Blowing from north to south at four miles per hour.			Defender: Wind will carry dust signatures and sound towards the enemy.		
Precipitation	10 percent chance of rain.			Defender: Track vehicle maneuverability-impaired.		
Cloud Cover	No cloud cover.			Neither		
Temperature	10 to 37 degrees F.			Defender: Effects on thermal system degradation.		
Humidity	N/A			N/A		
Light Data						
Star/Lunar Data	BMNT	Sunrise	Moonrise	Sunset	EENT	Moonset
	0657	0749	0729	1949	2042	1909
Who it favors	Defenders: Zero percent illumination will make dismounted movement slower, and Soldiers will make more noise because it is difficult to see.					
Legend:						
BMNT begin morning nautical twilight			EENT end of evening nautical twilight			
F Fahrenheit			N/A not applicable			

Troops and Support Available

2-94. Leaders study their TASKORG to determine the number, type, capabilities, and condition of available friendly troops and other support. They must understand the impact troops and available support have on the mission. For instance, the ambulance team that conducted mounted land navigation training and has several strong navigators may be best suited for mounted land navigation in new terrain. A very claustrophobic combat medic may not be the best choice for subterranean task. Leaders consider the following to help them understand the troops and support available:

- Determine the strengths and weaknesses of subordinate leaders. Consider the supply status of ammunition, water, fuel, and other necessary items.
- Assess the present physical condition of Soldiers (morale, sleep).
- Evaluate the condition of equipment.
- Determine the unit's training status and experience relative to the mission.

- Gauge additional Soldiers or augmenting units.
- Measure required additional assets to accomplish the mission.

2-95. Understanding each member of the medical platoon will help focus efforts on actual mission accomplishment tasks. The situation may warrant a long duration observation post while the unit may not have rehearsed or planned for this in the past. Identifying impacts early will aid in prioritizing rehearsals and possibly gathering and requesting additional materials and resources early in the planning process. Identifying facts early and developing possible solutions will ease the planning process during time-constrained planning.

Time

2-96. As addressed in the first step of TLP, time analysis is a critical aspect to planning, preparation, and execution. Time analysis is often the first thing a leader does. All time analysis should be nested with the higher headquarters' timeline and be reverse planned from LTIOV.

2-97. The leader must not only appreciate how much time is available, but they also appreciate the time and space aspects of preparing, moving, fighting, and sustaining. They must see their own tasks and enemy actions in relation to time. Most importantly, as events occur, they must adjust the time available and assess its impact on what they must accomplish. Finally, they must update previous timelines for their subordinates, listing all events that affect higher headquarters, the organization, and its subordinate elements which may help to answer a few questions concerning time —

- How does the medical platoon mission fit into the higher headquarters' mission?
- What times did the commander direct tasks to be accomplished?
- How long will each mission take?
- What critical times does the platoon leader have to meet to facilitate the higher headquarters' CCIR?
- What is the enemy's timeline?
- When is the LTIOV for the AHS support objective?
- How long will it take for the medical platoon to move from its current location to being set on the line of departure (LD)?
- How long will the platoon leader allow for planning and still ensure maximum time for rehearsals?

2-98. As stated before, plan and execute all AHS support activities in a time constrained environment. It can be beneficial to have a member of the treatment squad to keep track of the platoon's own timelines and provide warnings before tasks go over time. For example, if the platoon leader planned for 15 minutes to do terrain analysis, the designated medic will remind the platoon leader of the set time constraint to ensure the platoon stays on timeline. Creating a simple, flexible plan and conducting rehearsals early is far better than a perfect plan with no time for rehearsals.

2-99. While the platoon leader is conducting mission analysis, the rest of the platoon can execute tasks to prepare for the mission. The PSG can submit the supply requests and sensitive items report. The PSG will also enforce the security and rest plans.

2-100. Squad and TLs are following the timeline issued in the WARNORD. They can also correct deficiencies found during their PCCs. Leaders need to be prepared to assist the platoon leader with planning the platoon's scheme of maneuver.

2-101. Platoon members follow the timeline issued in the WARNORD, fix issues identified during PCCs and complete the PMCS of their equipment and vehicles. They also complete their individual, equipment, and vehicle camouflage.

2-102. Once mission analysis is complete, the platoon leader can move to developing the platoon scheme of maneuver. The platoon leader must not forget why they are executing the mission. It is easy to be sidetracked after focusing on terrain and enemy analysis. Before developing the scheme of maneuver, the platoon leader reviews the commander's intent, commander's AHS support guidance, mission statement, higher echelon scheme of fires, and all specified tasks and associated indicators. The platoon's scheme of maneuver must address the terrain, enemy, and all friendly requirements by clearly describing task, purpose, location, and effect to subordinate elements in time and space.

2-103. It is acceptable to have squad and TLs plan their own scheme of maneuver to maximize their experience and give them more confidence and understanding with the plan. The squad and TLs must graphically depict their plan for the medical platoon leader.

Civil Considerations

2-104. Civil considerations include the influences of man-made infrastructure; civilian institutions; and the attitudes and activities of civilian leaders, populations, and organizations within an AO, with regard to the conduct of military operations. Civil considerations generally focus on the immediate impact of civilians on operations in progress. The civil considerations can either help or hinder friendly or enemy forces; the difference lies in whether the platoon leader has taken time to learn the situation and its possible effects on the operation. The platoon leader's analysis of civil considerations answers three critical questions:

- How do civilian considerations affect the operation?
- How does the operation affect the civilians?
- How do our forces build national will in our AO?

2-105. The higher headquarters provides the platoon leader with civil considerations that may affect the next echelon's mission. A way that higher headquarters may analyze the civil considerations is cross-walking areas, structures, capabilities, organizations, people, and events with political, military, economic, social, information, and infrastructure. See ATP 2-01.3 for more information on intelligence preparation of the battlefield.

2-106. If the platoon leader gets the opportunity to see this information, they must remain focused. They must understand what specific civil considerations they are looking for as it pertains to their mission to maximize time in their analysis and planning.

2-107. Civil considerations may help drive decisions like a displaced persons plan, how long it will be safe to conduct society-focused medical support operations in an area, and where to focus medical support operations during stability tasks. Regardless of the mission, the medical platoon leader must have a general understanding of the civilian population in the AO.

STEP 4 – INITIATE MOVEMENT

2-108. Many of the battalion-level operations require movement to forward assembly areas and to battle positions during the planning phase of an operation. This means that elements of the medical platoon will also move to these locations in support of the battalion units. Medical platoon elements move with the supported units according to the battalion plan. As often as possible, within the restraints of operations security, medical TASKORG should be done during hours of daylight, or as early as possible. In spite of multiple “night vision technologies”, executing movements required by TASKORG is more efficiently accomplished in daylight. Activities may include ensuring AHS support for the battalion/company quartering party or beginning priorities of work.

2-109. Leaders initiate any movement necessary to continue mission preparation or to posture the unit for the start of the mission. Leaders may execute this step at any time throughout the sequence of TLP. It can include movement to an assembly area, battle position, or new AO, or the movement of guides or quartering parties.

2-110. If the platoon initiates some kind of movement during the planning process, the initial timeline issued during the WARNORD must reflect it. It may be beneficial to have the PSG control any movement during the planning process so the platoon leader has more time to plan. Section leaders can assist in planning the movement as well.

STEP 5 – CONDUCT RECONNAISSANCE

2-111. The conduct reconnaissance step of TLP allows the platoon leader to confirm the validity of their tentative plan. At a minimum, the medical platoon leadership conduct a detailed map reconnaissance to confirm their initial march route to the LD or start point and identify primary and alternate routes for MEDEVAC and preplanned sites for locating the BAS, medical treatment teams, or medical section while conducting bounding or extended medical coverage operations. If time and security considerations permit and authorization is obtained from higher headquarters, an on-site ground reconnaissance is the best way to survey the AO. In addition, the medical platoon leader should check with the intelligence staff for an intelligence update. If possible, they should also check some of the area beyond the LD, taking the medical PSG, treatment SQDLDR, and as many ambulance teams leaders as possible with them so they too can see the ground.

2-112. For offensive operations, the medical platoon leader should attempt to find a vantage point that will permit rapid accessibility to supported units while making use of natural terrain features to afford as much protection as possible for the BAS. Ground reconnaissance for offensive operations usually is limited to checking routes to the start point, the LD, and the axis just beyond the LD. For defensive operations, the medical platoon leader should conduct a reconnaissance of the unit position and the MEDEVAC routes to be used. Whenever tactically feasible, the platoon should make provisions to mark routes and locations for day and night operations during the reconnaissance. During the reconnaissance (or during battalion-level rehearsals), the medical platoon leader or their representative should coordinate evacuation routes with supported companies.

2-113. The platoon leader should know all reconnaissance tools are at their disposal. It may be possible to view unmanned aerial vehicle footage or graphics to look at MEDEVAC routes and locations for the Role 1 BAS.

STEP 6 – COMPLETE THE PLAN

2-114. The medical platoon leader refines the plan based on the results of the wargame, reconnaissance, and coordination with the brigade surgeon section, the BSMC, and supported battalion units. They then complete the plan using these results and any new information from their commander. They should keep the plan as simple as possible, at the same time ensuring that the AHS support plan supports the commander's intent and is complete.

2-115. Subordinates should complete a terrain model for the OPORD. It is helpful to have a member of the treatment squad make the terrain model as the squad member will usually be near the platoon leader and able to obtain copies of new graphics or changes and quickly adapt them to the terrain model.

2-116. The section sergeant or designated Soldier completes and/or ensures copies of all graphics are available; at a minimum, each vehicle commander will have a copy of all common operational graphics. The distribution of graphics to the vehicle level will help ensure complete understanding during the OPORD. It helps to have Soldiers with neat hand writing produce analog copies of the graphics to save time.

2-117. The platoon leader conducts their backbrief to the commander prior to issuing the platoon OPORD. They will describe how they intend to accomplish the mission and how their plan nests with the higher headquarters' plan. The platoon leader will bring a copy of all graphics they produced and give them to the commander. The PSG will conduct a backbrief with the battalion CSM and HHC 1SG to ensure the scheme of support and sustainment is feasible and nests with target reference points plan.

STEP 7 – ISSUE THE ORDER

2-118. Prior to the order, the medical PSG should ensure that all subordinate elements have copies of the overlays correctly posted to the maps and a copy of any matrixes from the battalion OPORD that covers key AHS support actions. All platoon members receiving the OPORD verbally should be prepared to copy these instructions in the five-paragraph OPORD format. They should ask for explanations of any terminology or

actions that they do not understand. If possible, the medical platoon leader issues the order from a vantage point overlooking the terrain on which the platoon will support the maneuver units. If not, they use a terrain model, sand table, sketches, or their map to orient the platoon. They can also build a model of the AO using a sand table briefing kit that contains such items as engineer tape, colored yarn, 3-by-5-inch index cards, and “micro” vehicle and tentage models.

2-119. When time and security permit, the medical platoon leader issues the order to as many members of the platoon as possible. At a minimum, the platoon leader assembles the treatment teams, ambulance squad, and combat medic section. The medical platoon leader briefs the platoon using the five-paragraph OPORD format. They should then send the ambulance emergency care SGT to brief the combat medics assigned to each of the maneuver companies.

2-120. To ensure complete understanding of the operation, the medical platoon leader and medical platoon personnel conduct confirmation briefings immediately after the OPORD is issued. The treatment and ambulance TLs backbrief the medical platoon leader and PSG to confirm their understanding. This includes the unit’s mission and intent and how it is nested with the higher headquarters’ mission, their own task(s) and purpose they must perform, and the relationship between their tasks and those of other medical units/elements in the operation and the commander’s AHS support plan. The medical platoon leader should lead the medical platoon in a walk-through using a sand table.

2-121. The OPORD precisely and concisely explains both the platoon leader’s intent and concept of how they envision the platoon accomplishing the mission. The order does not contain unnecessary information. The platoon leader delivers the OPORD quickly and in a manner that allows subordinates to concentrate on understanding the platoon leader’s vision and not just copying what they say verbatim. The platoon leader must prepare adequately and deliver the OPORD confidently and quickly to build and sustain confidence in their subordinates.

2-122. If addressing something discussed in previous WARNORDs during the OPORD, it is adequate to say “no change”. However, it may be beneficial to spot check a few subordinates understanding of information briefed as, no change. If the subordinates do not understand the information, clarify it to the group. The correct way to brief the OPORD is the one that conveys the information the subordinates need to know to accomplish the mission and to understand how their mission nests with the higher headquarters’ mission.

2-123. All members of the platoon should be present for the OPORD. Some circumstances may warrant the absence of some members of the platoon during the OPORD. When this is the case, the platoon leader should, at a minimum, brief their PSG, section, and SQDLDRs. The platoon leader allots additional time for them to brief their subordinates.

2-124. When the platoon leader finishes issuing the order, subordinate leaders should leave with a clear understanding of what the platoon leader expects their elements to do. All leaders are responsible for ensuring that their subordinates understand.

FIVE-PARAGRAPH OPERATION ORDER FORMAT

2-125. An order is a communication (verbal, written, or signaled) that conveys instructions from a superior to a subordinate. Commanders issue orders verbally or in writing. The five-paragraph format (situation, mission, execution, sustainment, and command and signal) remains the standard for issuing orders. Figure 2-6 on page 2-32 illustrates an OPORD checklist. The technique used to issue orders (verbal or written) is at the discretion of the commander; each technique depends on time and the situation:

- The situation paragraph is mostly derived from the intelligence preparation of the battlefield (IPB) process done during the mission analysis step of MDMP. The situation paragraph defines how the unit will be task-organized for the operation the OPORD covers. It includes defining the AO and the area of interest from IPB step 1 and set the boundaries to which the unit may operate in. Terrain analysis and weather come from IPB step 2 and describes the effects of the terrain and weather on the operation. Enemy situation come from IPB step 3 and 4 and describes enemy capability, characteristics, composition/ disposition and the most likely COA or most dangerous COA will be as prescribed by the intelligence staff. Lastly, higher mission one and two levels up ensures the mission in the OPORD is nested with the higher echelon's mission and commander's intent.
- The mission paragraph is one sentence that assigns the unit its overall mission. It should answer the questions who, what, where, why, and when. Each question should be answered as clearly as possible and have tactical tasks associated with it.
- The execution paragraph is the most important paragraph of the OPORD. It tells the unit exactly how the mission will be accomplished and the steps associated. This paragraph is also where subordinate units are tasked with their missions and any coordinating tasks. The concept of the operations is the overall steps to be accomplished in the mission. The scheme of maneuver is how the unit is going to execute the mission to meet the overall steps. Coordinating instructions include the timeline and the Priority Information Requirements, CCIRs, and friendly force information requirement for the operation.
- The sustainment paragraph explains how the unit will sustain the operation. It includes all classes of supply, medical operations and support, and detainee procedures. This paragraph is important for the medical platoon leadership to understand how the platoon will be resupplied during the operation.
- The command and signal paragraph denotes the location of commander, PACE plan and frequencies, and succession of command. These are important to understand and verify that the company has to correct frequencies and PACE plan in case of emergencies.

<p>1. SITUATION</p> <ul style="list-style-type: none"> • Task organization • Area of interest • Area of operations <ul style="list-style-type: none"> ▪ Terrain analysis <ul style="list-style-type: none"> – Obstacles – Avenues of approach – Key terrain – Observation and fields of fire – Cover and concealment ▪ Weather <ul style="list-style-type: none"> – Wind – Visibility – Temperature – Ceiling – Precipitation – Humidity • Enemy forces <ul style="list-style-type: none"> ▪ Composition ▪ Disposition ▪ Strength ▪ Capabilities ▪ MLCOA/MDCOA • Friendly forces <ul style="list-style-type: none"> ▪ Two levels up ▪ One level up ▪ Adjacent units • Attachments and Detachments <ul style="list-style-type: none"> ▪ Who/why <p>2. MISSION</p> <ul style="list-style-type: none"> • Mission statement • Concept of operations <ul style="list-style-type: none"> ▪ Who ▪ What ▪ When ▪ Where ▪ Why 	<p>3. EXECUTION</p> <ul style="list-style-type: none"> • Commander's intent • Concept of operations • Scheme of movement and maneuver (by phase) <ul style="list-style-type: none"> ▪ Describe from start to finish ▪ Fires ▪ Casualty evacuation • Tasks to subordinate units • Coordinating instructions <ul style="list-style-type: none"> ▪ Timeline ▪ Commanders critical information requirements (PIR/FFIR), EEFI ▪ Risk reduction control measures ▪ Rules of engagement ▪ Environmental considerations ▪ Force protection <ul style="list-style-type: none"> – Force health protection <ul style="list-style-type: none"> o Dental services o Veterinary services o Operational public health o COSC services o Medical laboratory services 	<p>4. SUSTAINMENT</p> <ul style="list-style-type: none"> • Logistics <ul style="list-style-type: none"> ▪ Maintenance ▪ Transportation ▪ Field Services • Personnel services support <ul style="list-style-type: none"> ▪ Handling of EPWs/ detainees • Health service support <ul style="list-style-type: none"> ▪ Medical treatment ▪ Medical evacuation ▪ Medical logistics <p>5. COMMAND AND CONTROL</p> <ul style="list-style-type: none"> • Command <ul style="list-style-type: none"> ▪ Location of leaders ▪ Medical command and control locations • Control <ul style="list-style-type: none"> ▪ Command post location • Signal <ul style="list-style-type: none"> ▪ Radio frequencies ▪ Passwords/running passwords ▪ Pyrotechnic signals 																				
<p>PRODUCTS</p> <ul style="list-style-type: none"> • Task Organization • Operations overlay (areas of operation, routes, units) • GDOT/MCOO (terrain analysis) • Doctrinal template • Situational template (enemy disposition and MLCOA) • Concept sketch (concept of operations) • Medical concept of support • Medical common operating picture (MEDCOP) • Scheme of maneuver graphics (each phase, often done on macro and micro terrain models) • Indirect fire overlay/targets on terrain model 																						
<p>Legend:</p> <table border="0"> <tr> <td>COSC</td> <td>combat and operational stress control</td> <td>MCOO</td> <td>modified combined obstacle overlay</td> </tr> <tr> <td>EEFI</td> <td>essential elements of friendly information</td> <td>MDCOA</td> <td>most dangerous course of action</td> </tr> <tr> <td>EPW</td> <td>enemy prisoner of war</td> <td>MLCOA</td> <td>most likely course of action</td> </tr> <tr> <td>FFIR</td> <td>friendly force information requirements</td> <td>PIR</td> <td>priority information requirements</td> </tr> <tr> <td>GDOT</td> <td>graphic depiction of terrain</td> <td></td> <td></td> </tr> </table>			COSC	combat and operational stress control	MCOO	modified combined obstacle overlay	EEFI	essential elements of friendly information	MDCOA	most dangerous course of action	EPW	enemy prisoner of war	MLCOA	most likely course of action	FFIR	friendly force information requirements	PIR	priority information requirements	GDOT	graphic depiction of terrain		
COSC	combat and operational stress control	MCOO	modified combined obstacle overlay																			
EEFI	essential elements of friendly information	MDCOA	most dangerous course of action																			
EPW	enemy prisoner of war	MLCOA	most likely course of action																			
FFIR	friendly force information requirements	PIR	priority information requirements																			
GDOT	graphic depiction of terrain																					

Figure 2-6. Operation order checklist

STEP 8 – SUPERVISE AND REFINE

2-126. Flexibility is the key to effective operations. The medical platoon leader must be able to refine their plan whenever new information becomes available. If they adjust the plan, they must inform the platoon, higher headquarters, and supervise implementation of the changes. Once the operation has begun, the medical platoon leader must be able to adapt in response to new situations and new orders. Platoon orders, backbriefs, rehearsals, and inspections are essential elements of the supervision process as the platoon prepares for the mission.

TEAM ORDERS

2-127. The platoon leader and the PSG make sure all ambulance team members have been briefed by SQDLDRs and understand the platoon mission and concept of the operation.

BACKBRIEFS

2-128. The backbrief is, in effect, a reverse briefing process; those who receive an OPORD confirm their understanding of the order by repeating and explaining details of the operation and review how subordinates intend to accomplish their mission for their leader or commander. In the medical platoon, the medical platoon leader should conduct backbriefs after the squad and TLs have had a chance to review the OPORD but before the platoon rehearsal begins. The squad and TLs brief the medical platoon leader on how their teams will accomplish the specific tasks assigned to them in the order.

2-129. The platoon leader and PSG make sure all platoon members receive backbriefs from their squad and TLs and understand the mission and concept of the operation. Squad and team briefings and rehearsals are essential to a successful operation. The platoon leader makes sure the entire platoon conducts PCCs and procedures according to the SOP.

Note. Although the backbrief is an effective means of clarifying the specifics of the plan, it does not require medical platoon personnel to practice or perform their assigned tasks. By itself, therefore, it is not an ideal rehearsal technique.

REHEARSALS

2-130. A *rehearsal* is a session in which the commander and staff or unit practices expected actions to improve performance during execution. (ADP 5-0). They are essential in ensuring thorough preparation, coordination, and understanding of the commander's plan and intent. Leaders should never underestimate the value of rehearsals. Leaders can change the type of rehearsal to fit the mission and time available. They may use map rehearsals, live rehearsals, and radio rehearsals to ensure that all elements of the plan are understood. For more information on rehearsals see FM 6-0. Leaders use well-planned, efficiently run rehearsals to accomplish the following:

- Reinforce training and increase proficiency in critical tasks.
- Reveal weaknesses or problems in the plan, leading to further refinement of the plan or development of additional contingency plans.
- Integrate the actions of subordinate elements (actions on contact and battle drills).
- Confirm coordination requirements between the company and adjacent units.
- Improve each Soldier's understanding of the concept of the operation, the direct fire plan, the indirect fires plan, anticipated contingencies, and possible actions and reactions for various situations that may arise during the operation.
- Ensure that subordinates are prepared to execute in their leader's absence.

2-131. Rehearsals are too often the first thing to cut when leaders use their time unwisely. When time is short, a rehearsal may be the best thing to develop subordinates understanding. Forcing subordinates to demonstrate their execution displays at a much higher level of understanding than saying—ROGER, I GOT IT.

INSPECTIONS

2-132. Inspections allow the medical platoon leader to check the platoon's operational readiness. The key goal is to ensure that Soldiers and vehicles are fully prepared to execute the upcoming mission. Inspections also contribute to improved morale. It is essential that all leaders in the medical platoon know how to conduct PCCs according to the platoon SOP.

2-133. The platoon leader and PSG should observe each crew during PCCs if possible, if it was not completed during the planning process. The platoon leader or PSG are responsible for conducting PCIs after the PCCs are complete and before execution. The PCI must be a "hands on, show me that it works" event. This is the only way to ensure the platoon is properly prepared. If trauma specialists and/or ambulance teams cannot return to the platoon, then their leader goes to inspect them. For more information on inspections, refer to section VI of this chapter.

ABBREVIATED TROOP LEADING PROCEDURES

2-134. When there is not enough time to conduct all eight TLP steps in detail, the platoon leader must understand how to trim TLP to save time. Most steps of these abbreviated TLP are done mentally. Upon receiving the order, the platoon leader conducts a quick map reconnaissance and analysis and then sends for the medical squad and team leadership. They make sure they post the minimum required control measures on their maps and give an abbreviated FRAGORD consisting of a quick friendly and enemy situation, the platoon mission, commander's intent, key tasks, and end state, AHS support guidance, and information requirements broken down into indicators with a time attached, and the concept of the operation. The PSG briefs adjustments to the scheme of support and sustainment. Standard operations procedures should clearly outline how the platoon will communicate and execute primary, alternate, contingency, and emergency (PACE) or, in the absence of orders, no communication plan.

2-135. When time is available, however, there is no substitute for effective preparatory instructions, a thorough tactical plan, and a formal OPORD. The odds of success increase considerably when conducting detailed planning and rehearsals prior to an operation, even when time is short. Successful platoon leaders make the most of every available minute. The medical platoon leadership may even be able to conduct a quick walk-through rehearsal of critical elements of the AHS support plan using a hastily prepared terrain model or sand table.

2-136. In some cases, there may not be enough time even for these shortened procedures. The platoon may have to move out and receive FRAGORD by radio or at the next scheduled halt. It then becomes critical for the medical platoon leader to send a FRAGORD of their own to the medical platoon explaining the platoon's requirements and objectives in supporting the battalion maneuver plan.

2-137. Digital and global positioning systems are valuable tools when the platoon is forced to use abbreviated TLP and FRAGORD. They allow the medical platoon leader to designate waypoints to assist in navigation and identifying evacuation routes.

2-138. Other keys to success when abbreviated procedures are in effect include a well-trained platoon; clearly developed, thoroughly understood SOP, training, and an understanding by all members of the platoon of the current tactical situation (situational understanding) enable the medical platoon to move and accomplish their mission with a minimum of formal orders. The medical platoon leadership must keep the platoon informed of the ever-changing friendly and enemy situations. They accomplish this by monitoring the battalion net and issuing frequent updates to the other platoon members using the radio and digital information systems. Specified delegation of tasks will also speed this process up.

2-139. Abbreviated TLP should not be the standard technique used by the platoon; it is a technique to use only when time is short. In some cases, there may not be enough time even for these shortened procedures.

SECTION IV – MILITARY DECISION-MAKING PROCESS

2-140. The *military decision-making process* is an iterative planning methodology to understand the situation and mission, develop a course of action, and produce an operation plan or order. Also called MDMP (ADP 5-0). Within the battalion, the medical platoon is unique as its leadership must execute both down and in when executing TLP for the medical platoon as part of the HHC and up and out as it executes MDMP in developing the AHS support plan for the battalion. It is important that the platoon's actions are synchronized with that of the company's and nest with the company's plan in support of the battalion.

CHARACTERISTICS OF MILITARY DECISION-MAKING PROCESS

2-141. The MDMP is one of the Army's three planning methodologies and is an orderly, analytical process that integrates the activities of the commander, staff, and subordinate headquarters in the development of a plan or order.

2-142. Before beginning an iteration of the MDMP, medical platoon leadership should review chapter 2 of ADP 5-0 to understand the fundamentals of planning. The MDMP helps leaders apply thoroughness, clarity, sound judgment, logic, and professional knowledge to understand situations, develop options to solve problems, reach decisions, and produce a plan or order that best accomplishes the mission. This process helps commanders, staffs, and others think critically and creatively while planning.

2-143. The MDMP facilitates collaborative planning. The higher headquarters solicits input and continuously shares information concerning future operations through planning meetings, WARNORDs, and other means. It shares information with subordinate and adjacent units, supporting and supported units, and unified action partners. Commanders encourage active collaboration among all organizations affected

by pending operations to build a shared understanding of the situation, participate in COA development and decision-making, and resolve conflicts before publishing the plan or order.

2-144. The MDMP also drives preparation. Since time is a factor in all operations, commanders and staffs conduct a time analysis early in the planning process. This analysis helps them determine when to begin certain actions to ensure forces are ready and in position before execution. This may require the commander to direct subordinates to start necessary movements, conduct TASKORG changes, begin information collection, and execute other preparation activities before completing the plan. As the commander and staff conduct the MDMP, they direct preparation tasks in a series of WARNORD.

2-145. Depending on the situation's complexity, commanders can initiate the Army design methodology before or in parallel with the MDMP. If the problem is hard to identify or the operation's end state is unclear, commanders may initiate Army design methodology before engaging in detailed planning. Army design methodology can assist the commander and staff in understanding the OE, framing the problem, and considering an operational approach to solve or manage the problem. The understanding and products resulting from Army design methodology guide more detailed planning during the MDMP. When used in parallel, the commander may direct some staff members to conduct mission analysis while engaging others in Army design methodology activities prior to COA development. Results of both mission analysis and Army design methodology inform commanders in development of their commander's intent and planning guidance. In time-constrained conditions, or when the problem is not complex, commanders may conduct the MDMP without incorporating formal Army design methodology efforts. During execution, the commander can use Army design methodology to help refine understanding and visualization as well as assessing and adjusting the plan as required.

THE SEVEN STEPS OF MILITARY DECISION-MAKING PROCESS

2-146. The MDMP consists of seven steps, as shown in figure 2-6 on page 2-38. Each step of the MDMP has inputs, a series of sub-steps, and outputs. The outputs lead to an increased understanding of the situation facilitating the next step of the MDMP. Commanders and staffs generally perform these steps sequentially; however, before producing the plan or order, they may revisit several steps in an iterative fashion as they learn more about the situation.

THE ROLE OF COMMANDERS, STAFFS, AND THE MEDICAL PLATOON IN MILITARY DECISION-MAKING PROCESS

2-147. The commander is the most important participant in the MDMP. More than simply decision-makers in this process, commanders use their experience, knowledge, and judgment to guide staff planning efforts. While unable to devote all their time to the MDMP, commanders follow the status of the planning effort, participate during critical periods of the process, and make decisions based on the detailed work of the staff. During the MDMP, commanders focus their activities on understanding, visualizing, and describing.

2-148. The MDMP stipulates several formal meetings and briefings between the commander and staff to discuss, assess, and approve or disapprove planning efforts as they progress. However, experience has shown that optimal planning results when the commander meets informally at frequent intervals with the staff throughout the MDMP. Such informal interaction between the commander and staff can improve the staff's understanding of the situation and ensure their planning efforts adequately reflect the commander's visualization of the operation.

2-149. The XO is a key participant in the MDMP. The XO manages and coordinates the staff's work and provides quality control during the MDMP. To effectively supervise the entire process, this officer has to clearly understand the commander's intent and guidance. The XO provides timelines to the staff, establishes briefing times and locations, and provides any instructions necessary to complete the plan.

2-150. The staff's effort during the MDMP focuses on helping the commander understand the situation, make decisions, and synchronize those decisions into a fully developed plan or order. Staff activities during planning initially focus on mission analysis. The products the staff develops during mission analysis help commanders understand the situation and develop the commander's visualization. During COA development and COA comparison, the staff provides recommendations to support the commander in selecting a COA. After the commander makes a decision, the staff prepares the plan or order that reflects the commander's intent, coordinating all necessary details (see figure 2-7 on page 2-38).

Key inputs	Steps	Key outputs	Medical outputs
<ul style="list-style-type: none"> Higher Headquarters' (HHQs') plan or order or a new mission anticipated by the commander 	<p>Step 1 Receipt of Mission</p>	<ul style="list-style-type: none"> Commander's initial guidance Initial allocation of time 	<ul style="list-style-type: none"> Commander's initial guidance Initial allocation of time <p>Warning order</p>
<ul style="list-style-type: none"> Commander's initial guidance HHQs' plan or order HHQs' knowledge and intelligence products Knowledge products from other organizations Army Design concept products (if developed) 	<p>Step 2 Mission Analysis</p>	<ul style="list-style-type: none"> Mission statement Initial commander's intent Initial planning guidance Initial CCIRs and EEFI Updated IPB and running estimates Assumptions Evaluate criteria for COAs 	<ul style="list-style-type: none"> Medical IPB to include health threat Initial casualty estimate (S-1) Medical running estimates <p>Warning order</p>
<ul style="list-style-type: none"> Mission statement Initial commander's intent, planning guidance, CCIRs, and EEFI Updated IPB and running estimates Assumptions 	<p>Step 3 COA Development</p>	<ul style="list-style-type: none"> COA statement and sketches Tentative task organization Broad concept of operations Revised planning guidance Updated assumptions 	<ul style="list-style-type: none"> Medical concept of support for each COA Casualty estimate for each COA (S-1) Refined medical running estimates for each COA
<ul style="list-style-type: none"> Updated running estimates Revised planning guidance COA statement and sketches Updated assumptions 	<p>Step 4 COA Analysis (War-Game)</p>	<ul style="list-style-type: none"> Refined COAs Potential decision points War-game results Initial assessment measures Updated assumptions 	<ul style="list-style-type: none"> Identify medical actions, reactions, and counteractions Identify medical risks associated with each COA Updated medical running estimates
<ul style="list-style-type: none"> Updated running estimates Refined COAs Evaluation criteria War-game results Updated assumptions 	<p>Step 5 COA Comparison</p>	<ul style="list-style-type: none"> Evaluated COAs Recommended COAs Updated running estimates Updated assumptions 	<ul style="list-style-type: none"> Updated medical running estimates
<ul style="list-style-type: none"> Updated running estimates Evaluated COAs Recommended COAs Updated assumptions 	<p>Step 6 COA Approval</p>	<ul style="list-style-type: none"> Commander approved COA and any modifications Refined commander's intent, CCIRs, and EEFI Updated assumptions 	<ul style="list-style-type: none"> Updated medical running estimates <p>Warning order</p>
<ul style="list-style-type: none"> Commander approved COA and any modifications Refined commander's intent, CCIRs, and EEFI Updated assumptions 	<p>Step 7 Orders Production, Dissemination, and Transition</p>	<ul style="list-style-type: none"> Approved operation plan or order Subordinates understand the plan or order 	<ul style="list-style-type: none"> Contribution to Annex E (Protection) Publication of Appendix 3 of Annex F (Sustainment)
<p>LEGEND: CCIR commander's critical information requirement EEFI essential element of friendly information COA course of action IPB intelligence preparation of the battlefield</p>			

Figure 2-7. The seven steps of military decision-making process

Rapid Decision-making and Synchronization Process

2-151. Rapid decision-making and synchronization process is used in place of MDMP when time constraints are placed on the planning process. As a medical planner, the rapid decision-making and synchronization process dictates that the best COA is brought forward to include any constraints, limitations, or risk that accompany the plan (see figure 2-8).

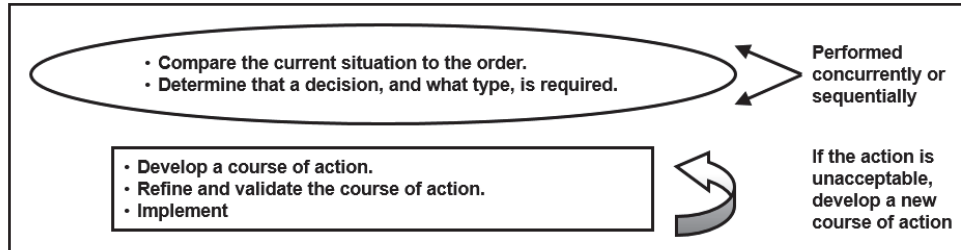

Figure 2-8. Rapid decision-making and synchronization process

STEPS OF MILITARY DECISION-MAKING PROCESS

2-152. Listed below are the key inputs and expected key outputs for each step. This includes a description of how the staff integrates IPB, targeting, risk management, and information collection throughout the MDMP. For detailed information on each step refer to FM 6-0, chapter 9.

STEP 1 – RECEIPT OF MISSION

2-153. Commanders initiate the MDMP upon receipt or in anticipation of a mission. This step alerts all participants of the pending planning requirements, enabling them to determine the amount of time available for planning and preparation and to decide on a planning approach, including guidance on using Army design methodology and how to abbreviate the MDMP, if required. When commanders identify a new mission, commanders and staffs perform the actions and produce the expected key outputs (see figure 2-9).

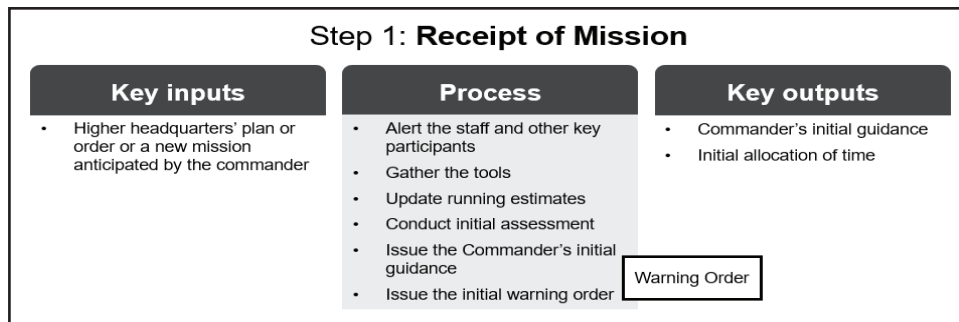

Figure 2-9. Step 1 – Receipt of mission

STEP 2 – MISSION ANALYSIS

2-154. The MDMP continues with an assessment of the situation called mission analysis. Commanders (supported by their staffs and informed by subordinate and adjacent commanders and by other partners) gather, analyze, and synthesize information to orient themselves on the current conditions of the OE. The commander and staff conduct mission analysis to better understand the situation and problem, and identify what the command must accomplish, when and where it must be done, and most importantly why—the purpose of the operation.

2-155. Since no amount of subsequent planning can solve an insufficiently understood problem, mission analysis is the most important step in the MDMP. This understanding of the situation and the problem allows commanders to visualize and describe how the operation may unfold in their initial commander's intent and planning guidance. During mission analysis, the commander and staff perform the process actions and produce the outputs shown in figure 2-9 on page 2-39.

2-156. Commanders and staffs also begin the development of evaluation criteria during this step. These evaluation criteria are continually developed and refined throughout the MDMP and become a key input during Step 5 - COA Comparison (see figure 2-10).

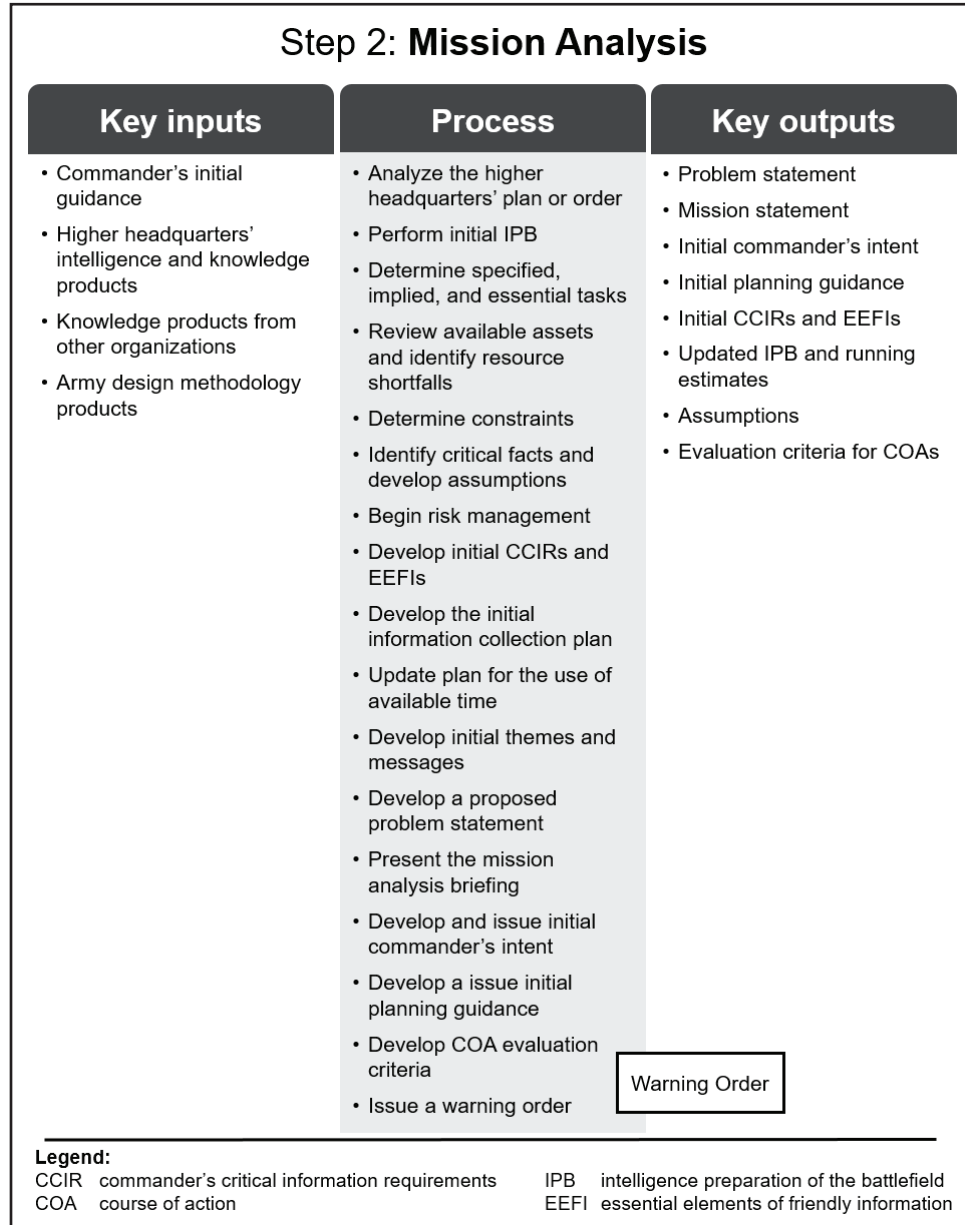

Figure 2-10. Step 2 – Mission analysis

2-157. Table 2-5 on page 2-42 lists the commander's planning guidance by warfighting function. This list is not intended to meet the needs of all situations nor be all-inclusive, and providing guidance by warfighting function is not the only method. Commanders tailor planning guidance to meet specific needs based on the situation rather than address

each item. Each item does not always fit neatly in a particular warfighting function, as it may be shared by more than one warfighting function.

Table 2-5. Examples of commander’s planning guidance by warfighting function

Command and Control	<ul style="list-style-type: none"> • Commander’s critical information requirements • Rules of engagement • Command post positioning • Commander’s location • Initial themes and messages • Succession of command 	<ul style="list-style-type: none"> • Liaison officer guidance • Planning and operational guidance timeline • Type of order and rehearsal • Communications guidance • Civil affairs operations • Cyber electromagnetic considerations • Medical command and control
Intelligence	<ul style="list-style-type: none"> • Information collection guidance • Information gaps • Most likely and most dangerous enemy courses of action • Priority intelligence requirements • Most critical terrain and weather factors 	<ul style="list-style-type: none"> • Most critical local environment and civil considerations • Intelligence requests for information • Intelligence focus during phased operations • Desired enemy perception of friendly forces
Movement and Maneuver	<ul style="list-style-type: none"> • Commander’s intent • Course of action development guidance • Number of courses of action to consider or not consider • Critical events • Task organization • Task and purpose of subordinate units • Forms of maneuver • Reserve composition, mission, priorities, and control measures 	<ul style="list-style-type: none"> • Security and counter reconnaissance • Friendly decision points • Branches and sequels • Task and direct collection • Military deception • Risk to friendly forces • Collateral damage or civilian casualties • Any condition that affects achievement of end state • Information operations
Fires	<ul style="list-style-type: none"> • Synchronization and focus of fires with maneuver • Priority of fires • High priority targets • Special munitions • Target acquisition zones • Observer plan • Air and missile defense positioning • High-value targets 	<ul style="list-style-type: none"> • Task and purpose of fires • Scheme of fires • Suppression of enemy air defenses • Fire support coordination measures • Attack guidance • Branches and sequels • No strike list • Restricted target list
Protection	<ul style="list-style-type: none"> • Protection priorities • Priorities for survivability assets • Terrain and weather factors • Intelligence focus and limitations for security • Acceptable risk • Protected targets and areas • Force Health Protection 	<ul style="list-style-type: none"> • Vehicle and equipment safety or security constraints • Environmental considerations • Unexploded ordnance • Operations security risk tolerance • Rules of engagement • Escalation of force and nonlethal weapons • Counterintelligence

Table 2-5. Examples of commander’s planning guidance by warfighting function (continued)

Sustainment	<ul style="list-style-type: none"> • Sustainment priorities: manning, fueling, fixing, arming, moving the force, and sustaining Soldiers and systems • Health service support • Sustainment of detainee and • resettlement operations 	<ul style="list-style-type: none"> • Construction and provision of facilities and installations • Detainee movement • Anticipated requirements of Classes III, IV, V, and VIII • Controlled supply rates
--------------------	---	--

STEP 3 – COURSE OF ACTION DEVELOPMENT

2-158. A COA is a broad potential solution to an identified problem. The COA development step generates options for subsequent analysis and comparison that satisfy the commander’s intent and planning guidance. During COA development, planners use the problem statement, mission statement, commander’s intent, planning guidance, and various knowledge products developed during mission analysis (see figure 2-11).

2-159. Embedded in COA development is the application of operational and tactical art. Planners develop different COAs by varying combinations of the elements of operational art, such as phasing, lines of effort, and tempo. (See ADP 3-0 for more information on operational art). Planners convert the approved COA into the concept of operations.

2-160. The commander’s direct involvement in COA development greatly aids in producing comprehensive and flexible COAs within the time available. To save time, the commander may also limit the number of COAs staffs develop or specify particular COAs not to explore. Planners examine each prospective COA for validity using the following screening criteria:

- Feasible. The COA can accomplish the mission within the established time, space, and resource limitations.
- Acceptable. The COA must balance cost and risk with the advantage gained.
- Suitable. The COA can accomplish the mission within the commander’s intent and planning guidance.
- Distinguishable. Each COA must differ significantly from the others (such as scheme of maneuver, lines of effort, phasing, use of the reserve, and TASKORG).
- Complete. A COA must incorporate—
 - How the decisive operation leads to mission accomplishment.
 - How shaping operations create and preserve conditions for success of the decisive operation or effort.
 - How sustaining operations enable shaping and decisive operations or efforts.
 - How to account for offensive, defensive, and stability or defense support of civil authorities tasks.

- Tasks to be performed and conditions to be achieved.

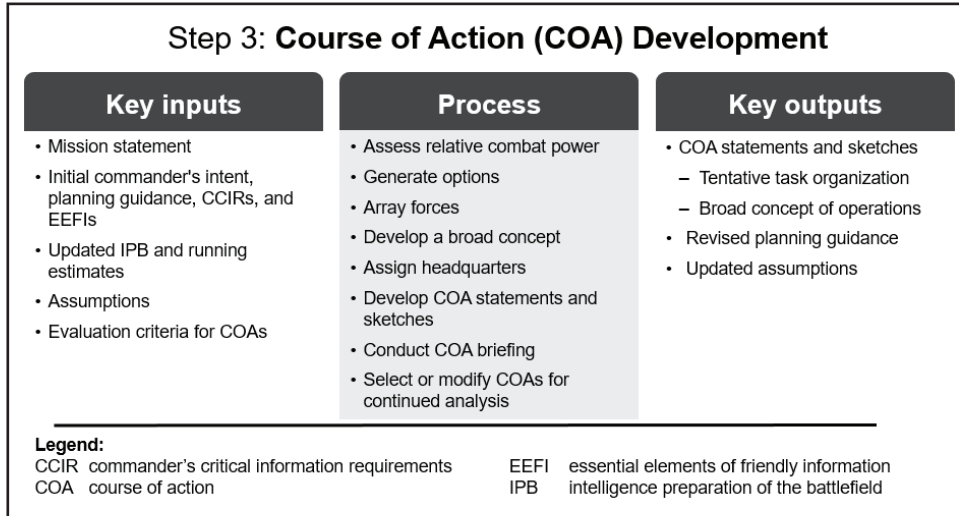

Figure 2-11. Step 3 – Course of action development

2-161. The operations staff prepares a COA statement and supporting sketch for each COA. The COA statement clearly portrays how the unit will accomplish the mission. The COA statement briefly expresses how the unit will conduct the combined arms concept. The sketch provides a picture of the movement and maneuver aspects of the concept, including the positioning of forces. Together, the statement and sketch cover who (generic TASKORG), what (tasks), when, where, and why (purpose) for each subordinate unit.

2-162. The COA sketch includes the array of generic forces and control measures, such as:

- The unit and subordinate unit boundaries.
- Unit movement formations (but not subordinate unit formations).
- The LD or line of contact and phase lines, if used.
- Information collection graphics.
- Ground and air axes of advance.
- Assembly areas, battle positions, strong points, engagement areas, and objectives.
- Obstacle control measures and tactical mission graphics.
- Fire support coordination and airspace coordinating measures.
- Main effort.
- Location of command post and critical communications nodes.
- Known or templated enemy locations.
- Population concentrations.

2-163. Planners can include identifying features (such as cities, rivers, and roads) to help orient users. The sketch may be on any medium. What it portrays is more important than its format (see figure 2-12 for a sample COA sketch and COA statement for a BCT using the operational framework of decisive-shaping-sustaining.)

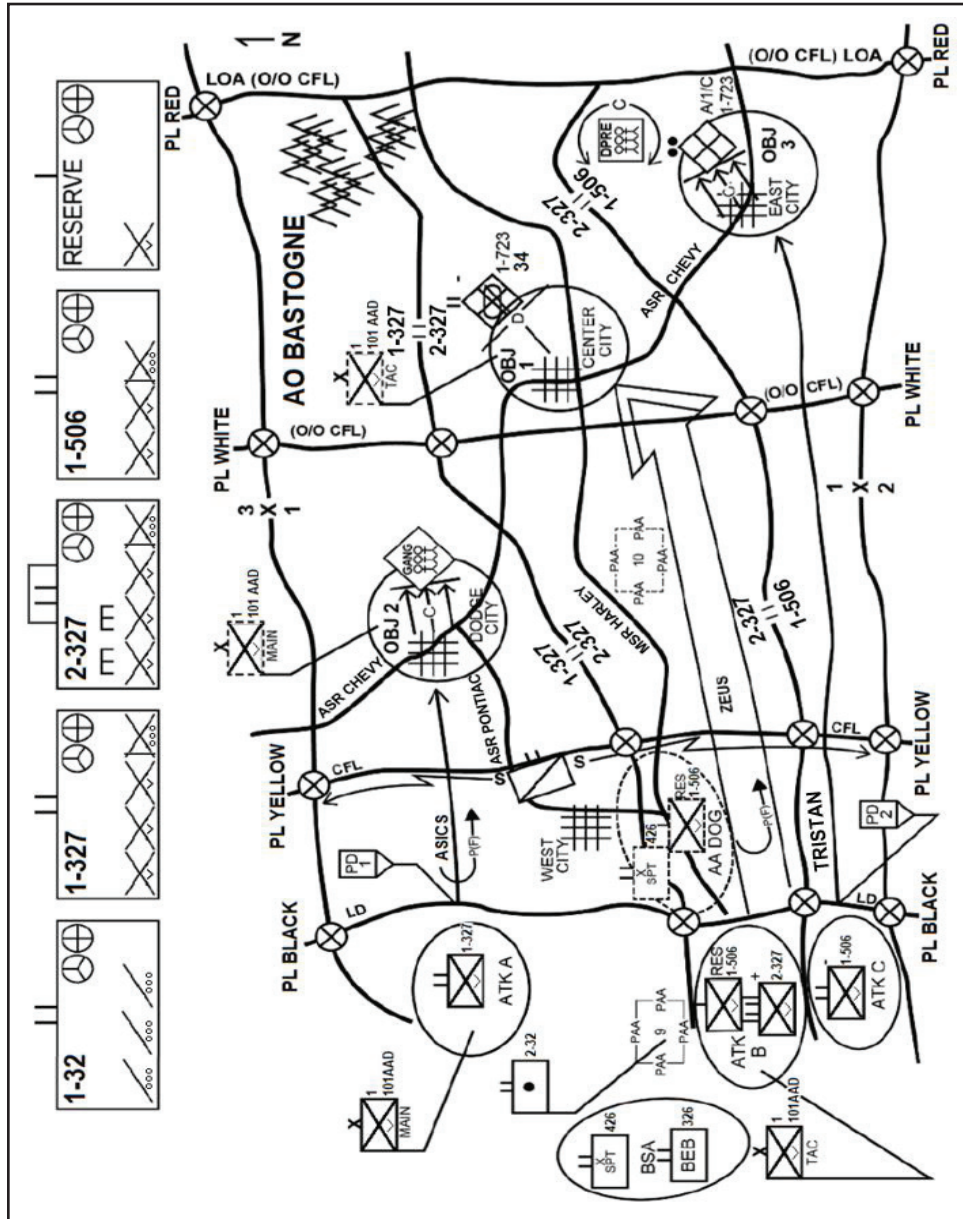

Figure 2-12. Sample brigade course of action sketch

<p>MISSION: On order, 1st IBCT destroys remnants of the 34th BDE in AO BASTOGNE to establish security and enable the host-nation in reestablishing civil control in the region.</p> <p>COMMANDER'S INTENT: The purpose of this operation is to provide a safe and secure environment in AO BASTOGNE to enable the host-nation and other civilian organizations to reestablish civil control, restore essential services, and reestablish local governance within the area. The key tasks are 1) destroy remnants of the 34th BDE; 2) secure population centers vic OBJ 1, 2, and 3; 3) transition authority to the host nation. At end state, the BCT has destroyed remnant of enemy forces in AO BASTOGNE, secured population centers, and is prepared to transition responsibility of security to host nation authority.</p> <p>INFORMATION COLLECTION: Priority of reconnaissance initially to locate enemy forces between PL BLACK (LD) and PL YELLOW. Information collection operations subsequently focus on 1) identifying the location and disposition of enemy forces vic OBJ 1; 2) observation of MSR HARLEY between PL YELLOW and PH WHITE; 3) observation of dislocated civilian traffic from CENTER CITY to EAST CITY.</p> <p>SHAPING OPERATIONS: 1-32 CAV initially screens along PL YELLOW IOT deny enemy reconnaissance and provide freedom of maneuver for follow on operations. On order, conducts FPOL at PL YELLOW IOT move TF 2-327 and 1-327 forward to conduct operations while maintaining contact with the enemy. O/O 1-327 in the north moves from ATK A, crosses LD at PD1 on DIRECTION OF ATTACK ASICS, conducts FPOL and clears hostiles vic OBJ 2 IOT enable NGO delivery of humanitarian assistance to WEST CITY AND DODGE CITY. TF 2-327 in the center occupies ATK B, IOT prepare for follow on operations. O/O 1-506 in the south moves from ATK C, crosses LD at PD 2, attacks along DIRECTION OF ATTACK NIKE, and clears enemy vic OBJ 3 IOT prevent disruption of DO vic OBJ 1. 326 BEB occupies BSA IOT set conditions for follow on operations. RESERVE initially establishes vic ATK B. On order, displace to AA DOG (east). Priority of commitment to DO vic OBJ 1.</p> <p>DECISIVE OPERATIONS: 1-32 CAV conducts FPOL vic PL YELLOW IOT move TF 2-327 forward to conduct operations while maintaining enemy contact. On order occupy AA DOG (south) IOT prepare for future operations. BPT conduct security operations northeastern portion of AO BASTOGNE IOT provide early and accurate warning of enemy or hostile threats to security of population centers. 1-327 controls ASRs CHEVY and PONTIAC in assigned AO IOT facilitate sustaining operations and prevent interference with DO vic OBJ 1.</p>	<p>O/O, TF 2-327 moves from ATK B along AXIS ZEUS; conducts FPOL, and attacks to destroy elements of the 34th BDE vic OBJ 1 IOT provide a secure environment for CENTER CITY population. Bypass criteria in platoon-size or smaller. 1-506 controls DPRE camp vic EAST CITY IOT provide a secure environment and control ASR CHEVY in assigned AO IOT facilitate sustaining operations and prevent interference with DO vic OBJ 1. 326 BEB conducts operations as required IOT support DO. RESERVE establishes in AA DOG (east). Priority of commitment is to reinforce DO vic OBJ 1.</p> <p>FIRE: (Shaping Operations): Priority of fires to 1-32 CAV, 1-327, TF 2-327, and 1-506 initially from PAA 9. O/O displace to PAA 10. HPTs are enemy reconnaissance forces, indirect fire systems, and mechanized infantry forces. (Decisive Operations): Priority of fires to TF 2-327, 1-506, 1-327, and 1-32 CAV from PAA 10. O/O displace to PAA 10. HPTs are enemy armor, mechanized infantry forces, and indirect fire systems. FSCM: CFL initially PL YELLOW, O/O PL WHITE, O/O RED (ROA).</p> <p>SUSTAINING OPERATIONS: (Shaping Operations): 426 BSB will initially establish operations in BSA. O/O, establish BSA in AA DOG vic (WEST CITY using MSR HARLEY, ASR CHEVY, and ASR PONTIAC as primary routes IOT sustain operations. Establish FLEs as required to support operations. Priorities of support to 1-32 CAV will be Class III, V, VIII, maintenance, and medical. (Decisive Operations): Priority of support to TF 2-327 will be Class III, V, VIII, maintenance, and medical. Coordinate humanitarian relief agencies IOT facilitate rapid restoration of essential services in AO BASTOGNE.</p> <p>MISSION COMMAND: (Command): 1st IBCT commander located with TAC CP and executive officer located with MAIN CP through mission. (Control/Signal): 1st IBCT MAIN CP initially located vic ATK A. O/O, displaces vic OBJ 2. 1st IBCT TAC CP initially located vic ATK B. O/O displaces vic OBJ 1.</p> <p>RISK: Based on intelligence reports of negative enemy activity in the northeast mountainous portion of AP BASTOGNE, risk is assumed with no ground maneuver forces initially allocated to conduct reconnaissance or surveillance operations. Mitigation will be accomplished by assigning a BPT to 1-32nd CAV to conduct security operations IOT provide early and accurate warning of enemy and hostile threats to the security of population centers.</p>																																																																																																
<p>Legend:</p> <table border="0"> <tr> <td>AA</td> <td>assembly area</td> <td>BPT</td> <td>be prepared to</td> <td>DPRE</td> <td>displaced persons, refugees, and evacuees</td> <td>PL</td> <td>phase line</td> </tr> <tr> <td>AAD</td> <td>air assault division</td> <td>BSA</td> <td>brigade support area</td> <td>FSCM</td> <td>forward support coordination measures</td> <td>RES</td> <td>reserve</td> </tr> <tr> <td>AO</td> <td>area of operations</td> <td>BSB</td> <td>brigade support battalion</td> <td>FLE</td> <td>forward logistics element</td> <td>SE</td> <td>supporting effort</td> </tr> <tr> <td>ASR</td> <td>alternate supply route</td> <td>CAB</td> <td>combat aviation brigade</td> <td>FPLO</td> <td>forward passage of lines</td> <td>SPT</td> <td>support</td> </tr> <tr> <td>ATK</td> <td>attack position</td> <td>CAV</td> <td>cavalry</td> <td>HPT</td> <td>high payoff targets</td> <td>TAC</td> <td>tactical</td> </tr> <tr> <td>BCT</td> <td>brigade combat team</td> <td>CFL</td> <td>coordinated fire line</td> <td>IBCT</td> <td>infantry brigade combat team</td> <td>TF</td> <td>task force</td> </tr> <tr> <td>BDE</td> <td>brigade</td> <td>CP</td> <td>command post</td> <td></td> <td></td> <td>vic</td> <td>vic</td> </tr> <tr> <td>BEB</td> <td>brigade engineer battalion</td> <td>DO</td> <td>decisive operations</td> <td></td> <td></td> <td></td> <td></td> </tr> </table>	AA	assembly area	BPT	be prepared to	DPRE	displaced persons, refugees, and evacuees	PL	phase line	AAD	air assault division	BSA	brigade support area	FSCM	forward support coordination measures	RES	reserve	AO	area of operations	BSB	brigade support battalion	FLE	forward logistics element	SE	supporting effort	ASR	alternate supply route	CAB	combat aviation brigade	FPLO	forward passage of lines	SPT	support	ATK	attack position	CAV	cavalry	HPT	high payoff targets	TAC	tactical	BCT	brigade combat team	CFL	coordinated fire line	IBCT	infantry brigade combat team	TF	task force	BDE	brigade	CP	command post			vic	vic	BEB	brigade engineer battalion	DO	decisive operations					<table border="0"> <tr> <td>IOT</td> <td>in order to</td> <td>PL</td> <td>phase line</td> </tr> <tr> <td>LD</td> <td>line of departure</td> <td>RES</td> <td>reserve</td> </tr> <tr> <td>LOA</td> <td>limit of advance</td> <td>SE</td> <td>supporting effort</td> </tr> <tr> <td>MSR</td> <td>main supply route</td> <td>SPT</td> <td>support</td> </tr> <tr> <td>O/O</td> <td>on order</td> <td>TAC</td> <td>tactical</td> </tr> <tr> <td>OBJ</td> <td>objective</td> <td>TF</td> <td>task force</td> </tr> <tr> <td>PAA</td> <td>position area of artillery</td> <td>vic</td> <td>vic</td> </tr> <tr> <td>PD</td> <td>point of departure</td> <td></td> <td></td> </tr> </table>	IOT	in order to	PL	phase line	LD	line of departure	RES	reserve	LOA	limit of advance	SE	supporting effort	MSR	main supply route	SPT	support	O/O	on order	TAC	tactical	OBJ	objective	TF	task force	PAA	position area of artillery	vic	vic	PD	point of departure		
AA	assembly area	BPT	be prepared to	DPRE	displaced persons, refugees, and evacuees	PL	phase line																																																																																										
AAD	air assault division	BSA	brigade support area	FSCM	forward support coordination measures	RES	reserve																																																																																										
AO	area of operations	BSB	brigade support battalion	FLE	forward logistics element	SE	supporting effort																																																																																										
ASR	alternate supply route	CAB	combat aviation brigade	FPLO	forward passage of lines	SPT	support																																																																																										
ATK	attack position	CAV	cavalry	HPT	high payoff targets	TAC	tactical																																																																																										
BCT	brigade combat team	CFL	coordinated fire line	IBCT	infantry brigade combat team	TF	task force																																																																																										
BDE	brigade	CP	command post			vic	vic																																																																																										
BEB	brigade engineer battalion	DO	decisive operations																																																																																														
IOT	in order to	PL	phase line																																																																																														
LD	line of departure	RES	reserve																																																																																														
LOA	limit of advance	SE	supporting effort																																																																																														
MSR	main supply route	SPT	support																																																																																														
O/O	on order	TAC	tactical																																																																																														
OBJ	objective	TF	task force																																																																																														
PAA	position area of artillery	vic	vic																																																																																														
PD	point of departure																																																																																																

Figure 2-12. Sample brigade course of action sketch (continued)

STEP 4 – COURSE OF ACTION ANALYSIS AND WAR-GAMING

2-164. Course of action analysis enables commanders and staffs to identify difficulties or coordination problems as well as probable consequences of planned actions for each COA being considered. It helps them think through the tentative plan. COA analysis may require commanders and staffs to revisit parts of a COA as discrepancies arise. Course of action analysis not only appraises the quality of each COA, but it also uncovers potential execution problems, decisions, and contingencies. In addition, COA analysis influences how commanders and staffs understand a problem and may require the planning process to restart (see figure 2-13).

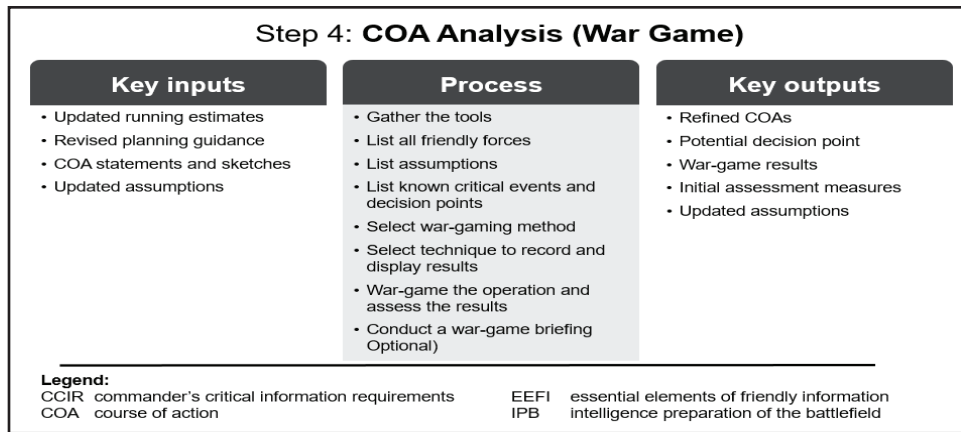

Figure 2-13. Step 4 – Course of action analysis and war-gaming

STEP 5 – COURSE OF ACTION COMPARISON

2-165. Course of action comparison is an objective process to evaluate COAs independently and against set evaluation criteria approved by the commander and staff. The goal is to identify the strengths and weaknesses of COAs, enable selecting a COA with the highest probability of success, and further developing it in an OPLAN or OPORD. The commander and staff perform certain actions and processes that lead to key outputs (see figure 2-14).

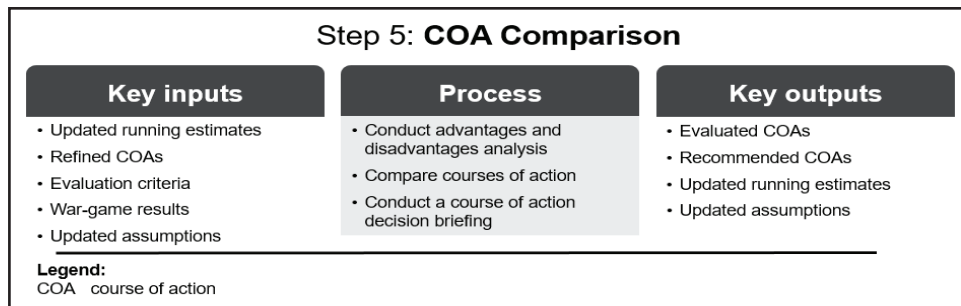

Figure 2-14. Step 5 – Course of action comparison

STEP 6 – COURSE OF ACTION APPROVAL

2-166. After the decision briefing, the commander selects the COA to best accomplish the mission. If the commander rejects all COAs, the staff starts COA development again. If the commander modifies a proposed COA or gives the staff an entirely different one, the staff then war-games the new COA and presents the results to the commander with a recommendation (see figure 2-15).

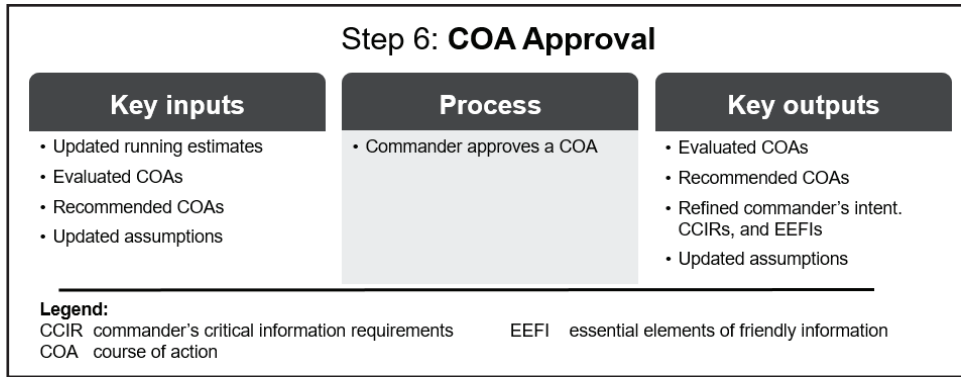

Figure 2-15. Step 6 – Course of action approval

STEP 7 – ORDERS PRODUCTION, DISSEMINATION, AND TRANSITION

2-167. The staff prepares the order or plan by turning the selected COA into a clear, concise concept of operations and the required supporting information. The COA statement becomes the concept of operations for the plan. The COA sketch becomes the basis for the operation overlay. If time permits, the staff may conduct a more detailed war game of the selected COA to more fully synchronize the operation and complete the plan. The staff writes the OPORD or OPLAN using the Army's OPORD format (see figure 2-16).

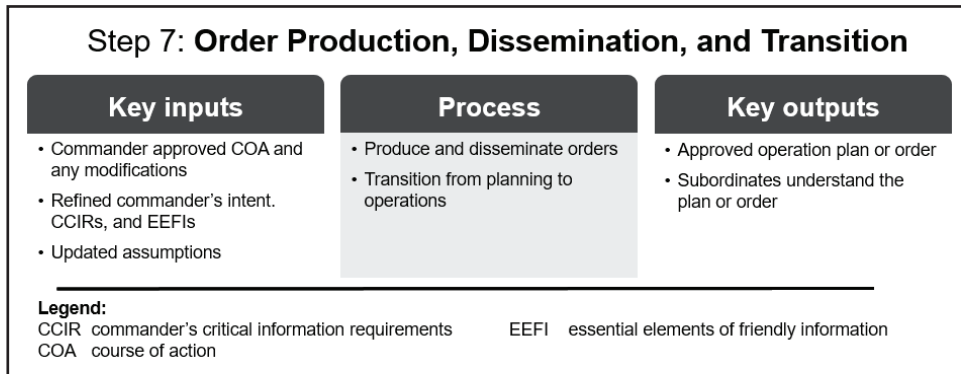

Figure 2-16. Step 7 – Orders production, dissemination, and transition

2-168. It is important to remember that the platoon leader is both a staff officer and a platoon leader. Therefore, the platoon leader writes the medical portion of the battalion operations order, the same order they will be issuing to the platoon during subsequent TLP. The platoon leader must remember that tasks to subordinate units and coordinating instructions will be executed by the subordinate maneuver companies, where the Soldiers from the combat medic section are attached. Those medics will be executing those instructions under the direct supervision of the company leadership. If a rehearsal with the entire platoon, including those medics, is not possible, the tasks and instructions in the order must be clear.

SECTION V – RISK MANAGEMENT

2-169. The medical platoon requires bold, aggressive, resourceful, and adaptive leaders—leaders of character, competence and commitment—who are willing to accept risks to accomplish the mission. Risk management is the process of identifying, assessing, and controlling risks arising from operational factors and making decisions that balance risk cost with mission benefits. The Army uses risk management to help maintain combat power while ensuring mission accomplishment in current and future operations. Risk management applies to both operations and to nonoperational activities. It is an essential element of the Army operations process, MDMP, TLP, and other organizational planning processes. Army forces manage risk throughout the operations process using the five steps of risk management (see figure 2-17).

RISK MANAGEMENT PROCESS

2-170. Leaders at all levels manage risk to protect the force and aid in mission accomplishment and so the company commander/platoon leader identifies risks based on the results of their mission analysis. Hazards are conditions with the potential to cause personnel injury, equipment or property damage, environmental harm, or mission degradation. Leaders utilize the mission variables of METT-TC to identify hazards.

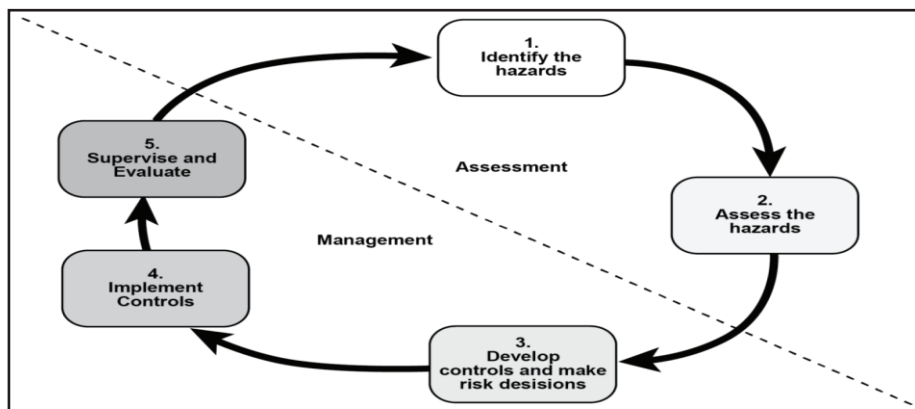

Figure 2-17. Risk management process

2-171. When hazards are assessed and risk levels are assigned, the resulting analysis is a measurement of risk—probability and severity of loss linked to hazards. In the context of risk management, probability is the likelihood an event will occur; it is assessed as frequent, likely, occasional, seldom, or unlikely. In the context of risk management, severity is the expected consequences of an event in terms of injury, property damage, or other mission-impairing factors; it is assessed as catastrophic, critical, moderate, or negligible. Risk assessment is a continual process undertaken by the company commander/platoon leader and PSG throughout the duration of the mission.

RISK MITIGATION AND CONTROL

2-172. Once identified, risk is mitigated or eliminated through the use of controls. The commander will establish overall risk tolerance level for the mission. Platoon leaders/platoon commanders determine in their plan how to reduce risk to an acceptable level. For example, fratricide may be mitigated by taking into consideration surface danger zones and risk estimate distances, resulting in the emplacement of target reference points and phase lines used to control maneuver and thus reduce this risk.

2-173. Implementing controls takes place during the preparation, execution, and evaluation phases of any mission or activity. Selected controls are translated into the operations order, orders brief, rehearsals, and also integrated with training events. Leaders must be engaged as supervisors to ensure that risk management controls are properly implemented. Leaders supervise to find and correct complacency, indiscipline, and lack of understanding. They must also maintain situational awareness to identify new hazards, and adjust controls as necessary based, and include risk management evaluation criteria when conducting AARs. Refer to GTA-21-08-001 and ATP 5-19 for more information on the risk management process.

SECTION VI – REHEARSALS

2-174. Effective rehearsals require personnel to perform required tasks, ideally under conditions that are as close as possible to those expected for the actual operation. Participants maneuver their actual vehicles or use vehicle models or simulations while interactively verbalizing their element's actions. In a platoon-level rehearsal, the medical platoon leader will select the tasks to be practiced and will control execution of the rehearsal.

2-175. The medical platoon leader can choose among several methods in conducting rehearsals, which should follow the crawl-walk-run training methodology to prepare the platoon for increasingly difficult conditions.

2-176. Rehearsals at echelon as well as within the medical platoon are critical to knowing the plan and executing well under pressure or when obstacles arise. The medical platoon at a minimum should be included in the brigade sustainment rehearsal, battalion sustainment rehearsal, battalion combined arms rehearsal, battalion CASEVAC, and internal MASCAL rehearsal, roles and responsibilities backbrief, and

a patient decontamination lane rehearsal. For more information on rehearsals see FM 6-0 and CALL Handbook 19-18.

REHEARSAL PURPOSES

2-177. Platoon leaders/PSG use well-planned, efficiently run rehearsals to accomplish the following purposes:

- Reinforce training and increase proficiency in critical tasks.
- Reveal weaknesses or problems in the plan.
- Synchronize the actions of the medical platoon.
- Confirm coordination requirements between the platoon and adjacent units.
- Improve each crewmember's understanding of the concept of the operation, the direct and indirect fire plan, anticipated contingencies, and possible actions and reactions for various situations that may arise during the operation.

REHEARSAL TYPES

2-178. The four types of rehearsal are discussed below.

BACKBRIEF

2-179. A *backbrief* is a briefing by subordinates to the commander to review how subordinates intend to accomplish their mission (FM 6-0). The backbrief is performed throughout the preparation process and is used by subordinates to confirm they understand the commander's intent. Backbriefs require the fewest resources and are often the only option under time-constrained conditions. The treatment and evacuation squads, sections, and teams explain their actions from the start to the finish of the mission. Backbriefs are performed sequentially, with all leaders reviewing their tasks. When time is available, backbriefs can be combined with other types of rehearsals. Doing this lets all subordinate leaders coordinate their plans before performing more elaborate drills.

COMBINED ARMS REHEARSAL

2-180. Performed by the maneuver unit in an effort to ensure subordinate units synchronize their plans with each other to meet the commander's intent. Attendance at the battalion combined arms rehearsal is crucial for the medical platoon to understand the maneuver elements in time and space and understand where they fit into the overall scheme of maneuver to provide the best support. The platoon leader may not be given an opportunity to brief in the combined arms rehearsal, however; they should ensure there is an inject in the rehearsal and use that opportunity to brief patient flow (including PACE, time distance analysis, and load capacity) from POI to Role 2. This rehearsal type helps ensure that subordinate commanders' plans achieve the higher commander's intent.

SUPPORT REHEARSAL

2-181. The support rehearsal is used to synchronize each warfighting function with the overall operation. A *warfighting function* is a group of tasks and systems united by a common purpose that commanders use to accomplish missions and training objectives. (ADP 3-0). This rehearsal supports the operation so units can accomplish their missions. The support rehearsal at the brigade and battalion levels is the rehearsal most applicable for the medical concept of support to reach the maneuver elements and create a more defined MEDCOP. How the medical platoon plans to support the operation, patient flow including flow of CLASS VIII, TACEVAC, CASEVAC, and MEDEVAC are good examples for this type of rehearsal.

BATTLE DRILL OR SOP REHEARSAL

2-182. A *battle drill* is a rehearsed and well understood actions made in response to common battlefield occurrences (ADP 3-90). A battle drill or SOP rehearsal ensures that all participants understand a technique or a specific set of procedures. Throughout preparation, medical platoons rehearse battle drills and SOPs. These rehearsals do not need a completed order from higher headquarters. Leaders place priority on those drills or actions they anticipate occurring during the operation. For example, an ambulance team may rehearse a battle drill on actions conducted at an AXP while waiting to begin movement. While it's important for the medical platoon to understand common battle drills like react to indirect contact, some of the most important rehearsals will be unique to the platoon's SOP. Set up and tear down of the Role 1 should be a common and practiced battle drill as well as MASCAL procedures that vary by unit. Lastly, an important rehearsal that is often neglected is a patient decontamination lane. GTA 03-08-002 and ATP 4-02.7/MCRP 3-40A.6/NTTP 4-02.7/AFTTP 3-42.3, outline a patient decontamination lane which every Role 1 BAS has the capability of running. The lane will be ineffective if it is never rehearsed.

2-183. Effective participation means—

- Know the audience. Leaders are not going to brief the same thing at the brigade sustainment rehearsal that you did at the battalion sustainment rehearsal. The things you brief at the brigade level are going to be the things that help define the MEDCOP. The things you brief at the battalion level are the services you are providing to the companies.
- Make the backbriefs effective. After doing TLP with the platoon, ask them questions relevant to what they will be doing. The evacuation teams need to know frequencies whereas treatment is more concerned with number and type of injuries they may be seeing based on mission. The medical planner should also backbrief the battalion XO/operations officer to ensure they understand all the operational terms and the unit's task and purpose.
- Have a script. Writing everything word for word is not the preferred method as leaders should know their plan and make eye contact with the personnel being briefing, however, not having cue words or an outline may cause leaders to start stumbling and forget an important detail their audience needs to know. Leaders do not need to brief everything but they need to know

everything. The load capacity for a certain company may not be relevant due to them expecting zero casualties based off the casualty estimate, however, leaders still need to know what their load capacity is in case they are asked that question or it applies elsewhere. The neighboring battalion needs a flex from that company's evacuation crew.

- Show up early. Nothing looks worse than when leaders cannot find what they are looking for on the map. Leaders should show up early and know where the features are that they will be referencing.
- Have one of the subordinates, such as a treatment NCO, familiar with the plan accompany the leader to the rehearsal to assist with maps, sand tables, or briefing slides. While briefing, it is less distracting if the leader remains stationary and have someone else point and move pieces on the visual aid.

METHODS OF REHEARSALS

2-184. Rehearsals should follow the crawl-walk-run methodology whenever possible. Methods for conducting rehearsals are limited only by the medical platoon leaders or PSGs imagination and available resources (see figure 2-18). Resources required for each method range from broad to narrow. As listed from left to right, each successive method takes more time and more resources:

- Time—the amount of time required to conduct (plan, prepare, execute, and assess) the rehearsal.
- Echelons involved—the number of echelons that can participate in the rehearsal.
- Operations security risks—the ease by which an enemy can exploit friendly actions from the rehearsal.
- Terrain—the amount of space needed for the rehearsal.

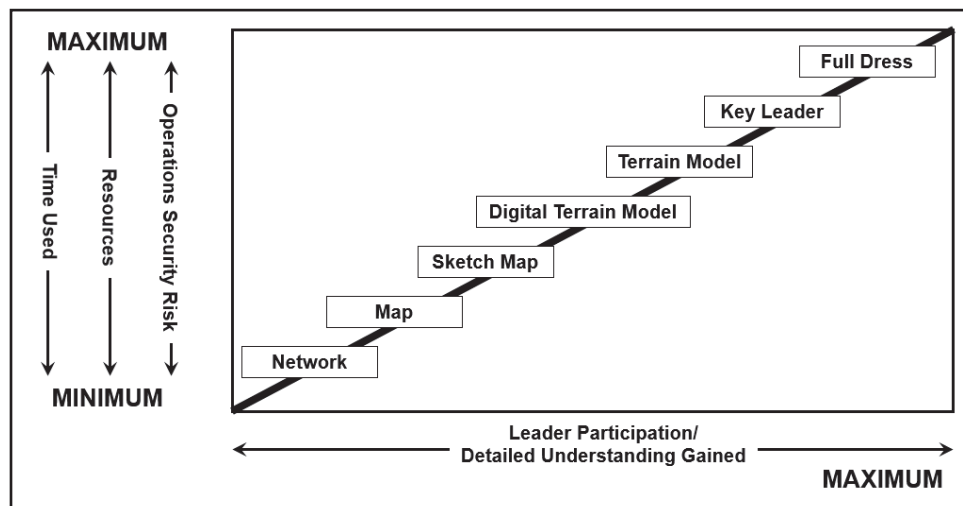

Figure 2-18. Methods of rehearsals

2-185. Each rehearsal method also imparts a different level of understanding to participants. This prepares the platoon for increasingly difficult conditions. Refer to FM 6-0 for more information. Security must be maintained, however, units can conduct if mission variables permit, the following rehearsals—

- Full-dress.
- Key leader.
- Terrain-model.
- Digital terrain-model.
- Sketch-map.
- Map.
- Network.

FULL-DRESS REHEARSAL

2-186. The full-dress rehearsal is the most effective, but consumes the most time and resources. A full-dress rehearsal includes every participating platoon member and system and is executed on terrain similar to the AO initially under good light conditions and then in limited visibility. Any attachments to the platoon take part in this rehearsal, bringing with them any specific equipment they will require to execute the mission.

KEY LEADER REHEARSAL

2-187. This rehearsal involves only key leaders of the organization and subordinate units and normally takes fewer resources than a full-dress rehearsal. Terrain requirements mirror those of a full-dress rehearsal. A key-leader rehearsal can be used to prepare key leaders for a full-dress rehearsal. The medical platoon leader conducts this method of rehearsals when time is limited or the tactical situation does not permit everyone to attend. Platoon members, who can take part, practice their actions on mock-ups, sand tables, or actual terrain (usually over a smaller area than in the actual operation).

TERRAIN-MODEL REHEARSAL

2-188. This technique employs an accurately constructed model to help subordinates visualize the battle. When possible, the platoon leader/PSG places the terrain model near, or where it overlooks, the actual terrain of the AO. The model should be large enough to depict graphic control measures and important terrain features for reference and orientation. Based on size, participants walk or move “micro” vehicles and/or equipment around the table or model, using complete radio transmission, to practice the actions of their own vehicles in relation to other members of the platoon. One consideration is to conceal the terrain model from enemy air assets.

DIGITAL TERRAIN-MODEL REHEARSAL

2-189. Units drape high-resolution imagery over elevation data, creating a fly through or walk-through of the mission. Often, the model links graphics, detailed information, unmanned aircraft systems, and ground imagery to key points providing accurate insight to the plan.

SKETCH-MAP REHEARSAL

2-190. Sketch-map procedures are similar to those for the terrain model rehearsal. The sketch must be large enough to allow all participants to see as each subordinate “walks” through an interactive oral presentation of their actions. Squads and sections can use symbols or “micro” vehicles and/or equipment to represent their locations and maneuver on the sketch and use complete radio transmissions when executing their movements.

MAP REHEARSAL

2-191. Procedures are similar to those for the sketch-map rehearsal except that the leader uses a map and operation overlay of the same scale as the platoon leader/PSG used to plan and control the operation. This technique is useful in conjunction with a confirmation brief or backbrief involving subordinate leaders and vehicle commanders.

NETWORK REHEARSAL

2-192. Units conduct network rehearsals over wide-area networks or local-area networks. Commanders and staffs practice these rehearsals by talking through critical portions of the operation over communications networks in a sequence the commander establishes. The organization rehearses only the critical parts of the operation. These rehearsals require all information systems needed to execute that portion of the operation. All participants require working information systems, the OPORD, and graphics. The CP can rehearse battle tracking during network rehearsals.

SECTION VII – PRECOMBAT CHECKS AND INSPECTIONS

2-193. Precombat checks and PCIs are critical to the success of missions. These checks and inspections are leader tasks and cannot be delegated below the TL level. They ensure the Soldier is prepared to execute the required individual and collective tasks supporting the mission. Checks and inspections are part of TLP protecting against shortfalls endangering Soldiers' lives and jeopardizing the execution of a mission.

2-194. Precombat checks and PCIs must be tailored to the specific unit and mission requirements. Each mission and each patrol may require a separate set of checklists. Each element will have its own established set of PCCs and PCIs, but each platoon within its element should have identical checklists. Weapons squads will have a different checklist than line squads, but each weapon squad within an organization should be the same.

2-195. One of the best ways to ensure PCCs and PCIs are complete and thorough is with full-dress rehearsals. These rehearsals, run at combat speed with communication and full battle-equipment, allow the leader to envision minute details, as they will occur in the area of operation. If the operation is to be conducted at night, Soldiers should conduct full-dress rehearsals at night as well. PCCs and PCIs should include backbriefs on the mission, the task and purpose of the mission, and how the Soldiers' roles fits into the scheme of maneuver. The Soldiers should know the latest intelligence updates, rules of engagement, and be versed in MEDEVAC and CASEVAC procedures and sustainment requirements.

2-196. It is essential that the entire platoon chain of command know how to conduct PCCs and PCIs per applicable SOPs. Table 2-6 lists sensitive items, high dollar value items, issued pieces of equipment, and supplies (refer to FM 6-99 for formatting of reports and request). This table should spur thought; it is not a final list. Follow the unit TACSOP guidelines.

PRECOMBAT CHECKS

2-197. Precombat checks differ from PCIs in that they are quick combat checks performed at team-level and designed to account for individuals and equipment. Precombat checks do not require formal notification to conduct. They are designed to be quick and concise, verifying that the team has all necessary equipment to accomplish the mission. Examples for PCCs include the following:

- Perform weapon pre-fire checks; report or repair deficiencies, if necessary.
- Zero all weapons, refer all sights, and check ammunition to ensure that they are stored properly.
- Upload vehicles per the platoon SOP.
- Cross load medical supplies and equipment for tail gate medicine.
- Account for crews' uniforms and equipment necessary to accomplish the tasks.

Note. The standardization of load plans allows the platoon leader and PSG to quickly check accountability of equipment. It also ensures standard locations of equipment in each vehicle. This can be an important advantage if the platoon leader is forced to switch to a different vehicle during an operation.

PRECOMBAT INSPECTIONS

2-198. Precombat inspections allow the platoon leader to check the platoon's operational readiness. The key goal is to ensure that the medical platoon and its vehicles are fully prepared to execute the upcoming mission. The platoon leader includes the time and location for PCIs in the platoon OPORD, reinforcing their importance and ensuring they occur as part of TLP.

2-199. It is essential that the entire platoon chain of command know how to conduct PCCs and PCIs per applicable SOPs. Examples of an inspection include the following:

- Perform before-operation maintenance checks, and report or repair deficiencies, if necessary.
- Perform communications checks of voice and digital systems.
- Inspect and verify maps and corresponding analog and digital graphics.
- Ensure that the platoon understands the plan and are in the correct uniform and mission-oriented protection posture (MOPP) level based upon the threat level.
- Verify ammunition quantities and types as required by mission.

- Review the supply status of rations, water, fuel, oil, all types of ammunition, medical, and batteries (for such items as flashlights, night vision devices, and CBRN alarms).
- Ensure that vehicles are correctly camouflaged so they match the AO.

Table 2.6. Precombat checks and precombat inspection checklist example

<i>Individual</i>	<i>Leader</i>
Identification (ID) card/ID tags Advanced combat helmet with night vision mount Night vision devices (mounted, functional, and tied down) Ballistic eye protection Weapon (zeroed, clean, function test, sling attached properly, and tied down) Optics (tied down, zeroed, preventive maintenance checks services (PMCS), extra batteries) Magazines (7 each, 30 rounds per) Weapons cleaning kit Radios and backup communication Global positioning satellite device Individual body armor (tailored to mission, plates, side plates, name tape and rank) Individual first aid kit inventoried Canteen or water bladder Protective mask with auto injectors Uniform complete with combat boots Knee and elbow pads Rucksack with mission specific packing list inventoried Entrenching tool Poncho with liner Improved rain suit top and bottom Visual signal (VS)-17 panel Infrared strobe Flashlight Chemical lights Meals/food Map, protractor, and lensatic compass Notebook/pen/pencil Hearing protection Lip balm/sunscreen Insect repellent Camouflage stick Batteries and spare batteries Equipment packed according to standard operation pro 9-line medical evacuation procedures Aid bag packed and inventoried for mission Briefed on current mission Know locations of ambulance exchange points (AXPs) and casualty collection points (CCPs)	Graphics Communication Communication card Map, protractor, and compass Binoculars Whistle Alcohol pens Sensitive items list Report formats, as applicable: <ul style="list-style-type: none"> ● Chemical, biological, radiological, nuclear 1 report ● Logistics resupply request ● Maintenance support request ● Medical evacuation request ● Medical location report ● Medical situation report ● Medical spot report ● Personnel status report ● Spot report ● Situation report ● Sensitive items report ● Slant report ● Vehicle recovery request Marking kits. As applicable: <ul style="list-style-type: none"> ● drop zone ● helicopter landing zone ● landing zone ● pick-up zone Aid bag inspection Battle drills rehearsed Coordinate AXPs with supporting units Coordinate CCPs with supported units Medical equipment set inspection Route reconnaissance Sector sketches pre-formatted Sling load equipment inspection Vehicle inspection (PMCS)

SECTION VIII – AFTER ACTION REVIEWS

2-200. An *after action review* is a guided analysis of an organization's performance, conducted at appropriate times during and at the conclusion of a training event or operation with the objective of improving future performance. It includes a facilitator, event participants, and other observers (FM 7-0). See FM 7-0 for more information on AARs.

INTRODUCTION TO AFTER ACTION REVIEWS AND REPORTS

2-201. Leaders can use AARs not only for training situations, but also for operations. Leaders can also employ AARs during pauses in action, as individual missions are completed, or after phases of the operation as time permits, enabling units to also learn during operations. An AAR enables an organization to objectively ascertain its mastery of tasks.

2-202. The AAR is the written record of a unit's AAR, or a consolidation of comments, lessons learned, or best practices during the course of an operation or exercise. The after action report documents a unit's actions for historical purposes and highlights key lessons learned and best practices. Commanders systematically collect, use, and share lessons learned and best practices throughout an operation or extended training event. Additionally, lessons learned and best practices are available for consideration and application by the operating and generating force through the Center for Army Lessons Learned and the Medical Center of Excellence (MEDCoE) Lessons Learned Branch.

2-203. After action reviews are conducted as needed during and following a training event. Participants record observations, insights, and lessons learned for future use to identify trends and prevent reoccurrences of improper practices. The AAR is a structured review process, formal or informal, that allows training participants to discover for themselves what happened, why it happened, and how they can perform better. As a professional discussion, the AAR requires active participation of those being trained to be effective. The AAR is not a critique.

FORMAL AND INFORMAL AFTER ACTION REVIEWS

2-204. Two types of AAR exist: formal and informal. Commanders generally conduct formal AAR after completing a mission. Normally, only informal AAR are possible during the conduct of operations.

2-205. Leaders plan formal AAR when they complete an operation or otherwise realize they have the need, time, and resources available. Formal AAR require more planning and preparation than informal AAR. Formal AAR require site reconnaissance and selection; coordination for aids (such as terrain models and large-scale maps); and selection, setup, maintenance, and security of the AAR site. During formal AAR, the AAR facilitator (unit leader or other facilitator) provides an overview of the operation and focuses the discussion on topics the AAR plan identifies. At the conclusion, the

facilitator reviews identified and discussed key points and issues, and summarizes strengths and weaknesses.

2-206. Leaders use informal AAR as on-the-spot coaching tools while reviewing Soldier and unit performance during or immediately after execution. Informal AAR involve all Soldiers. These AAR provide immediate feedback to Soldiers, leaders, and units after execution. Ideas and solutions leaders gathered during informal AAR can be applied immediately as the unit continues operations. Successful solutions can be identified and transferred as lessons learned.

2-207. Formal and informal AAR generally follow the same format:

- Review what was supposed to happen. The facilitator and participants review what was supposed to happen. This review is based on the commander's intent for the operation, unit operation or FRAGORD, the mission, and the concept of operations.
- Establish what happened. The facilitator and participants determine to the extent possible what actually happened during execution. Unit records and reports form the basis of this determination. An account describing actual events as closely as possible is vital to an effective discussion. The assistant chief of staff, intelligence provides input about the operation from the enemy's perspective.
- Determine what was right or wrong with what happened. Participants establish the strong and weak points of their performance. The facilitator guides discussions so that the conclusions the participants reach are operationally sound, consistent with Army standards, and relevant to the OE.
- Determine how the task should be done differently next time. The facilitator helps the chain of command lead the group in determining how participants might perform the task more effectively. The intended result is organizational and individual learning that can be applied to future operations. If successful, this learning can be disseminated as lessons learned.

2-208. Leaders understand that not all tasks will be performed to standard. In their initial planning, they allocate time and other resources for retraining after execution or before the next operation. Retraining allows participants to apply the lessons learned from AAR and implement corrective actions. Retraining should be conducted at the earliest opportunity to translate observations and evaluations from AAR into performance in operations. Commanders ensure Soldiers understand that training is incomplete until the identified corrections in performance have been achieved. Successful lessons can be identified as lessons learned and disseminated.

2-209. After action reviews are often tiered as multiechelon leader development tools. Following a session involving all participants, senior commanders may continue AAR with selected leaders as extended professional discussions. These discussions usually include a more specific review of leader contributions to the operation's results. Commanders use this opportunity to help subordinate leaders master current skills and prepare them for future responsibilities. After action reviews are opportunities for knowledge transfer through teaching, coaching, and mentoring.

2-210. Commanders conduct a final AAR during recovery after an operation. This AAR may include a facilitator. Unit leaders review and discuss the operation. Weaknesses or shortcomings identified during earlier AAR are identified again and discussed. If time permits, the unit conducts training to correct these weaknesses or shortcomings in preparation for future operations.

2-211. Lessons learned can be disseminated in at least three ways. First, participants may make notes to use in retraining themselves and their sections or units. Second, facilitators may gather their own and participants' notes for collation and analysis before dissemination and storage for others to use. Dissemination includes forwarding lessons to other units conducting similar operations as well as to the Center for Army Lessons Learned, doctrinal proponents, and institutional force agencies. Third, units should publicize future successful applications of lessons as lessons learned.

BENEFITS OF AFTER ACTION REVIEWS

2-212. After action reviews are the dynamic link between task performance and execution to standard. Through the professional, candid discussion of events, Soldiers can identify what went right and what went wrong during the operation using measures of effectiveness. When appropriate, they can evaluate their performance of tasks using measures of performance.

2-213. The discussion helps Soldiers and leaders identify specific ways to improve unit proficiency. Units achieve the benefits of AAR by applying their results. Applications may include organizing observations, insights, and lessons learned; revising how the unit executes TTP; and developing future training.

2-214. After action reviews may reveal problems with unit SOPs. If so, unit leaders revise the procedures and ensure that the unit implements the changes during future operations. Leaders can use the knowledge that AAR develop to assess performance, correct deficiencies, and sustain demonstrated task proficiency. These improvements will enhance unit performance in future operations.

CONDUCTING AFTER ACTION REVIEWS

2-215. Effective AAR require planning and preparation. During planning for an operation, commanders allocate time and resources for conducting AAR and assign responsibilities for them. The amount and level of detail needed during planning and preparation depends on the type of AAR and the resources available. The AAR process has four steps:

- Step 1-Plan.
- Step 2-Prepare.
- Step 3-Execute.
- Step 4-Follow-up (using after action reports).

2-216. After action reviews during operations differ from those during training in the lack of observer controllers or observer trainers. During operations, there are no dedicated collectors of data and observations. Instead, unit generated assessments of the operation's progress form the basis of the AAR.

PLANNING AFTER ACTION REVIEWS

2-217. An AAR plan provides the foundation for a successful AAR. Commanders and leaders develop a plan for each AAR as time allows. The plan specifies—

- Who will conduct the AAR.
- Who will provide information.
- What aspects of the operation the AAR should evaluate.
- Who will attend the AAR.
- When and where the AAR will occur.
- What aids are used for the AAR.
- Who is responsible for recording the AAR.

2-218. Commanders, leaders, or facilitators use the AAR plan to identify critical places and events that must be covered to provide a useful AAR. Examples include the decisive operation, critical transitions, and essential tasks. The AAR plan also includes who will address each event.

2-219. Commanders and leaders specify what they want to accomplish with the AAR and what the AAR will address. The OPORD may provide tasks and conditions. Measures of effectiveness and some measures of performance are extracted from the order. Army Doctrine Reference Publication (ADRP) 1-03 contains recommended measures of performance to develop training and evaluation outline evaluation criteria for supporting tasks. The primary source for standards for most Army units is their proponent-approved collective tasks.

2-220. Copies of the OPORD and daily journal are given to the senior facilitator. The senior facilitator distributes these to the AAR team members to review and use them to identify critical events and times for discussion during the AAR.

Scheduling After Action Reviews

2-221. Commanders and leaders plan for an AAR at the end of each operation whenever possible. The AAR planner should decide the scope of the AAR and allocate sufficient time. Quality AAR help Soldiers receive better feedback on their performance and remember lessons longer.

Determining Who Will Attend

2-222. The AAR plan specifies who the commander wants to attend AAR. At each echelon, an AAR has a primary set of participants. At squad and platoon levels, all Soldiers should attend and participate. At company and higher levels, it may not be practical to have everyone attend because of operations or training. In this case, unit commanders, other unit leaders, and other key players may be the only participants. Based on their observations, facilitators may recommend additional participants.

Choosing After Action Review Aids

2-223. Appropriate aids add to an AAR effectiveness; however, facilitators use an aid only if it makes the AAR better. Aids should promote learning and directly support discussion of the operation. Dry-erase boards, video equipment, terrain models,

enlarged maps, and unit information systems are all worthwhile under the right conditions. Terrain visibility, group size, suitability for the task, and availability of electric power are all considerations when selecting AAR aids.

Preparing the After Action Review Plan

2-224. The AAR plan is only a guide. Commanders and facilitators should review it regularly to make sure it still applies and meets the unit's needs. The plan may be adjusted as necessary, but changes take preparation and planning time away from facilitators and leaders. The AAR plan should allow facilitators and leaders as much time as possible to prepare.

PREPARING FOR AFTER ACTION REVIEW

2-225. Preparation is key to effectively executing any plan. Facilitators begin to prepare for an AAR before the operation and continue preparations until the actual event. Facilitators announce to unit leaders the starting time and location as soon as possible after these are set. This lets unit leaders account for personnel and equipment, perform post-operation actions, and move to the AAR site while facilitators are preparing and rehearsing.

Reviewing Objectives, Orders, Plans, and Doctrine

2-226. Facilitators review the unit's mission before the AAR. The mission's objectives form the AAR focus and the basis for observations. Facilitators review current doctrine, technical information, and applicable unit SOPs to ensure they have the tools needed to properly guide discussion of unit and individual performance. Facilitators read and understand all WARNORD, OPORD, and FRAGORD issued before and during execution to understand what the commander wanted to happen. The detailed knowledge that facilitators display as a result of these reviews gives added credibility to their comments.

Identifying Key Events

2-227. Facilitators identify critical events and ensure they collect data on those events or identify personnel who observed them. Examples of critical events include, but are not limited to:

- Issuance of OPORD and FRAGORD.
- Selected planning steps.
- Contact with opposing forces.
- Civil security attacks while conducting stability tasks.
- Passages of lines and reliefs in place.

Collecting Observations

2-228. Facilitators need a complete picture of what happened during the operation to conduct an effective AAR. Each facilitator for subordinate, supporting, and adjacent units provides the senior facilitator with a comprehensive review of collected data on their organizations and the impact those units had on the unit accomplishing its mission.

2-229. The senior facilitator receives input on the enemy from the intelligence staff. The enemy's perspective is critical to identifying why a unit succeeded or not. During formal AAR, the intelligence staff briefs what is known of the enemy's plan and intent to set the stage for discussing what happened and why it happened. Obtaining this data after operations is extremely difficult; therefore, these observations often are treated as assumptions rather than facts.

2-230. During their review, facilitators accurately record what they learn about events by time sequence to avoid losing valuable information and feedback. Facilitators use any recording system that is reliable (notebooks and laptops), sufficiently detailed (identifying times, places, and names), and consistent.

2-231. Facilitators include the date-time group of each observation so they can easily integrate it with other observations. This practice provides a comprehensive and detailed overview of what happened. When facilitators have enough time, they review their notes and fill in any details not written down earlier.

2-232. One of the most difficult facilitator tasks is determining when and where to obtain information about the operation or the aspects of it selected for the AAR. Facilitators remain professional, courteous, and respectful at all times.

Organizing the After Action Review

2-233. Once facilitators have gathered all available information, they organize their notes chronologically to understand the flow of events. They select and sequence key events in terms of their relevance to the unit's mission and objectives. This helps them identify key discussion and teaching points.

2-234. An effective AAR leads participants to discover strengths and weaknesses, propose solutions, and adopt a COA to improve future operations. Facilitators organize an AAR using one of three methods: chronological order of events, warfighting functions, or key events, themes, or issues.

Chronological Order of Events

2-235. An AAR using the chronological order of events is logical, structured, and easy to understand. It follows the flow of the operation from start to finish. Covering actions in the order they occurred helps Soldiers and leaders better recall what happened. This method usually cannot cover all actions only critical events.

Warfighting Functions

2-236. This type of an AAR allows participants to discuss the operation across all its phases by warfighting function. This method identifies systemic strengths and weaknesses and is useful for staff growth and learning.

Key Events, Themes, or Issues

2-237. An AAR using key events, themes, or issues focuses the discussion on critical operational events that directly support achieving the AAR objectives. This works well when time is limited.

Selecting After Action Review Sites

2-238. After action reviews should occur at or near where the operation occurred. Leaders should identify and inspect the AAR site and prepare a diagram showing placement of aids and other equipment. A good site minimizes wasted time by allowing rapid assembly of key personnel and positioning of aids. For larger units, this might not be possible for the whole operation. However, higher echelon AAR may include visits to selected actual sites to provide learning opportunities.

2-239. The AAR site should let Soldiers see the terrain where the operation occurred or accurate representations of it. If this is not possible, facilitators find a location that allows Soldiers to see where the critical or most significant actions happened. Facilitators should have a map or other representation of the AO detailed enough to help everyone relate key events to the actual terrain. The representation may be a terrain model, enlarged map, or sketch. Facilitators also require a copy of the unit's graphics or recovered displays of the situation from the information systems databases.

2-240. Facilitators provide a comfortable setting for participants by encouraging Soldiers to remove helmets, providing shelter, and serving refreshments. These actions create an environment where participants can focus on the AAR without distractions. Participants should not face into the sun. Key leaders should have seats up front. Vehicle parking and equipment security areas should be far enough away from the AAR site to prevent distractions.

Rehearsing

2-241. After thorough preparation, the facilitator reviews the agenda and prepares to conduct the AAR. Facilitators may opt to conduct a walkthrough of the AAR site as well as review the sequence of events planned for the AAR.

EXECUTING AFTER ACTION REVIEWS

2-242. Facilitators start an AAR by reviewing its purpose and sequence—the ground rules, the objectives, and a summary of the operation that emphasizes the functions or events to be covered. This ensures that everyone present understands what the commander expects the AAR to accomplish.

INTRODUCTION AND RULES

2-243. The following rules apply to all AAR. Facilitators emphasize them in their introduction:

- An AAR is a dynamic, candid, professional discussion that focuses on unit performance. Everyone with an insight, observation, or question participates. Total participation is necessary to maintain unit strengths and to identify and correct deficiencies.
- An AAR is not a critique. No one—regardless of rank, position, or strength of personality—has all the information or answers. After action reviews maximize learning benefits by allowing Soldiers to learn from each other.
- An AAR assesses weaknesses to improve and strengths to sustain.

2-244. Soldier participation is directly related to the atmosphere created during the introduction. Effective facilitators draw in Soldiers who seem reluctant to participate. The following ideas can help create an atmosphere conducive to maximum participation:

- Reinforce the idea that it is permissible to disagree.
- Focus on learning and encourage Soldiers to give honest opinions.
- Use open-ended and leading questions to guide the discussion.
- Facilitate the discussion only when necessary.

REVIEW OF OBJECTIVES AND INTENT

2-245. After the introduction, facilitators review the AAR objectives. This review includes the following:

- A restatement of the events, themes, or issues being reviewed.
- The mission and commander's intent (what was supposed to happen).
- The enemy's mission and intent (how the enemy tried to defeat the force).

2-246. The commander or a facilitator restates the mission and commander's intent. Facilitators may guide the discussion to ensure that everyone present understands the plan and intent. Another method is to have subordinate leaders restate the mission and discuss the commander's intent. Automated information systems, maps, operational graphics, terrain boards, and other aids can help portray this information.

2-247. Intelligence personnel then explain as much of the enemy plan and actions as they know. The same aids the friendly force commander used can help participants understand how the plans related to each other.

SUMMARY OF EVENTS (WHAT HAPPENED)

2-248. The facilitator guides the review, using one of the methods to describe and discuss what actually happened. Facilitators avoid asking yes-or-no questions. They encourage participation and guide the discussion by using open-ended and leading questions. Open-ended questions allow those answering to reply based on what they think is significant. These questions are less likely to put Soldiers on the defensive. Open-ended questions work more effectively in finding out what happened.

2-249. As the discussion expands and more Soldiers add their perspectives, what really happened becomes clearer. Facilitators do not tell Soldiers and leaders what was good or bad. Instead, they ensure that the discussion reveals the important issues, both positive and negative. Facilitators may want to expand this discussion and ask, "What could have been done differently?" Skillful guiding of the discussion ensures that participants do not gloss over mistakes or weaknesses.

CLOSING COMMENTS (SUMMARY)

2-250. During the summary, facilitators review and summarize key points identified during the discussion. The AAR should end on a positive note, linking conclusions to learning and possible training. Facilitators then depart to allow unit leaders and Soldiers time to discuss the learning in private.

THE AFTER ACTION REPORT

2-251. One of the most important collection techniques used in the Army and many other organizations is the after action report. The concept of the after action report can be easily adapted to fit any unit's lessons learned program.

2-252. The after action report provides observations and insights from the lessons learned that allow the unit to reflect on the successes and shortcomings of the operation, and share these lessons with the Army.

2-253. The reporting unit organizes the after action report in a logical order, usually by operational phase or warfighting function. It should be arranged chronologically to facilitate the understanding and flow of the information reported. Documenting what worked well should receive as much attention as what did not.

2-254. Table 2-7 below is an example of what a commander and staff may elect to cover in their unit's written after action report. This approved brigade after action report template can apply across all echelons.

Table 2-7. After action report format

<ol style="list-style-type: none">1. Report cover page:<ol style="list-style-type: none">a. <i>Classification.</i>b. <i>Preparing headquarters or organization.</i>c. <i>Location of report preparation.</i>d. <i>Date of preparation.</i>e. <i>After action report title.</i>f. <i>Period covered: (date to date).</i>2. Preface or foreword signed by the commander.3. Table of contents. Keep information arranged in a logical order (by warfighting function, chronologically, or phases of operation.)4. Executive summary and chronology of significant events:<ol style="list-style-type: none">a. <i>Briefly summarize operations for all phases; include key dates for each phase starting with predeployment, transitioning through deployment, and ending with redeployment.</i>b. <i>Summarize task organization (TASKORG).</i>c. <i>Summarize key lessons learned (include level where lessons learned occurred).</i>d. <i>Summarize recommendations with timeline for correction to occur (makes it a historical document as leaders change units or missions).</i>5. Detailed TASKORG. Include any significant changes and dates as appropriate:<ol style="list-style-type: none">a. <i>Organizational diagrams, including attached units, elements, and named task forces, including enablers and clearance authorities.</i>b. <i>Highlight any significant TASKORG challenges (command and support relationships) and how they were mitigated.</i>c. <i>Effective dates of TASKORG to include all attached, operationally controlled units and individuals, including contractors.</i>6. Predeployment phase with dates:<ol style="list-style-type: none">a. <i>Unit's training focus:</i>b. <i>Describe the training plan.</i>c. <i>Unit having all of the elements that it would deploy with during training.</i>d. <i>Training as a combined arms team with all deploying assets participating.</i>e. <i>Using assets outside the unit to support training.</i>

Table 2-7. After action report format (continued)

<p>h. <i>Discuss lessons learned during predeployment operations. List what was planned but not executed.</i></p> <p>f. <i>Key and essential areas trained.</i></p> <p>g. <i>Describe what simulation systems (such as live, virtual, constructive, and gaming) were instrumental in training success.</i></p> <p>i. <i>Discuss logistics and personnel shortages, if appropriate.</i></p> <p>j. <i>Discuss planning for rear detachment operations.</i></p> <p>k. <i>Describe any major shifts in personnel or manning.</i></p> <p>l. <i>Coordination with non-military support agencies (unit associations, veterans groups, financial institutions, local government, and law enforcement).</i></p> <p>m. <i>Family readiness groups.</i></p> <p>n. <i>List of significant predeployment training lessons learned. (Use the "observation-discussion-recommendation" format).</i></p> <p>o. <i>List of significant gaps identified in leader development or proficiency?</i></p> <p>7. Deployment and reception, staging, onward movement, and integration (RSOI) with dates:</p> <p>a. <i>Summarize deployment and RSOI operations.</i></p> <p>b. <i>Discuss what portions of the RSOI process went as planned and what worked.</i></p> <p>c. <i>Identify the shortcomings and delays in the RSOI and why they occurred.</i></p> <p>8. Relief in place or transfer of authority with dates (if applicable):</p> <p>a. <i>Discuss planning and overlap.</i></p> <p>b. <i>List or discuss key topics between outgoing and incoming organizations.</i></p> <p>c. <i>Include (either here or as an appendix) any standard operating procedures, tactics, techniques and procedures (TTP), or checklists.</i></p> <p>d. <i>Discuss relief in place or transfer of authority lessons learned in the "observation-discussion recommendation" format.</i></p> <p>9. Operations phase with dates:</p> <p>a. <i>Summarize tactical and non-tactical operations (sometimes beneficial to do this by staff element or warfighting function).</i></p> <p>b. <i>Include unit participation in named operations.</i></p> <p>c. <i>List of key operation orders (OPORDs) and fragmentary orders (FRAGORDs).</i></p> <p>d. <i>Discuss operations phases (sometimes beneficial to address by warfighting function).</i></p> <p>e. <i>Discuss any command and control challenges.</i></p> <p>10. Redeployment activities with dates:</p> <p>a. <i>Summarize redeployment activities and highlight planning guidance either developed or received from higher headquarters.</i></p> <p>b. <i>Redeployment timeline.</i></p> <p>c. <i>List of critical losses, personnel, equipment, and information.</i></p> <p>d. <i>Include (either here or as an appendix) any list of instructions, TTP, or checklists developed.</i></p> <p>11. Postdeployment activities:</p> <p>a. <i>Discuss combat stress planning and reintegration activities.</i></p> <p>b. <i>Discuss plans and priorities used in reconnaissance, reconstituting, and resetting the unit.</i></p> <p>c. <i>Discuss family support group operations.</i></p> <p>12. Provide an index or listing of all mid-tour and final unit after action report products, significant command briefings, or reports published separately:</p> <p>a. <i>Include classification, titles, and distribution or disposition of reports.</i></p> <p>b. <i>Include a staff or section point of contact for follow-up coordination.</i></p> <p>c. <i>Include dates for scheduled umbrella week and warfighting function symposiums.</i></p> <p>13. Distribution (of this report).</p> <p>14. Appendixes (as appropriate):</p> <p>a. <i>List of each named operation or major event with dates.</i></p> <p>b. <i>Applicable maps.</i></p> <p>c. <i>Photographs.</i></p> <p>d. <i>Copies of key OPORDs and FRAGORDs.</i></p> <p>e. <i>Particularly useful TTP or unit products developed.</i></p> <p>f. <i>Predeployment site survey information.</i></p> <p>g. <i>Rear detachment operations.</i></p> <p>h. <i>Unit daily journals.</i></p>

SECTION IX – COMMUNICATIONS

2-255. Communications are vital to medical support operations. Regardless if the BAS is executing bounding or extended medical support operations or conducting a MASCAL, they must be able to relay that information to the command to be effective. Leaders place the same emphasis in their communications plan as any of the other warfighting functions. Because of the extended frontages and distances over which the medical platoon operates, it must rely heavily on effective communications techniques. These techniques include not only the means of communications (such as visual signals, radio, and digital systems) and the proper way of using them, but also the effective application of operational terms, radiotelephone procedures, and digital TTP.

MEDICAL PLATOON RADIO NETS

2-256. The leaders in the medical platoon employ and monitor many communication nets. Unit SOPs will dictate which communication system and which net will be used to communicate specific types of information. The medical platoon must ensure they can communicate within their team, with the battalion, with their supported units, and with any supporting EAB assets (see figure 2-19).

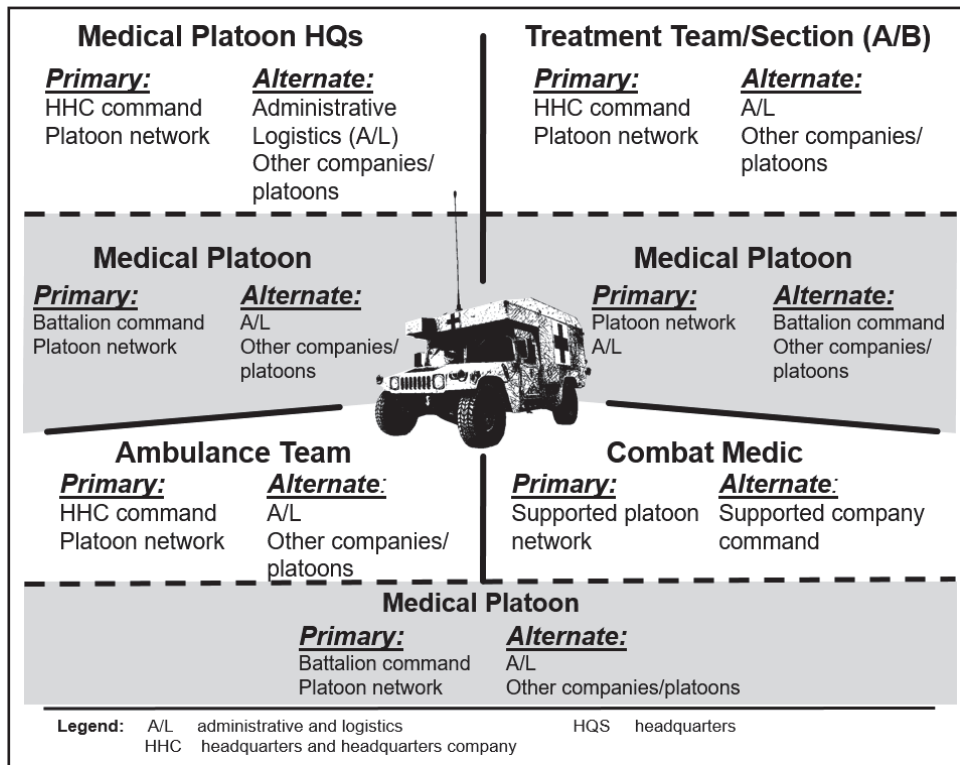

Figure 2-19. Example of medical platoon nets

PLATOON NETS

2-257. The platoon has access to the maneuver battalion HHC wire communications network for communications with all major elements of the battalion. Wireless communications for this section consists of a tactical FM radio mounted in the platoon headquarters vehicle. The medical platoon employs an FM radio network for AHS support operations. The platoon headquarters section serves as the net control station for the platoon.

2-258. The platoon net facilitates medical command and control. All elements within the medical platoon must have the ability to monitor and transmit on this net at all times. Making sure this happens is one of the keys to effective command and control during the conduct of tactical missions. All medical platoon personnel must also have the ability to rapidly change to any other platoon net as required to coordinate contact points or handover of medical responsibilities.

COMMAND NETS

2-259. All organic and attached units enter the battalion command net. Primarily, during the execution of the mission, only commanders transmit; all others monitor and transmit only essential information. The command net is controlled by the battalion main CP.

2-260. Command nets maneuver the medical platoon as well as processes most routine reports not sent on digital mission command systems. The CP is the net control station, and the medical platoon leader or PSG sends routine reports to the HHC XO and various staff sections.

2-261. Both the medical platoon headquarters and treatment teams A and B must always have the ability to monitor this net. All medical platoon personnel must be able to switch to this net to send reports and receive guidance if they are unable to contact their platoon leader or PSG.

ADMINISTRATIVE AND LOGISTICS NET

2-262. The administrative/logistics net is a tactical net, controlled by the CTCP, used to communicate the administrative and logistical requirements. All organic and attached units normally operate in this net.

2-263. The PSG usually monitors the administrative/logistics net for the platoon, but the platoon leader must be familiar with it as well. The PSG uses it as required to send routine A/L reports. This net also coordinates resupply and evacuation of casualties.

RETRANSMISSION

2-264. When the elements of the medical platoon operate at extended distances from the CP, they may use the retransmission net to facilitate effective communications between the medical platoon headquarters, treatment teams, or ambulance teams and the battalion or supported unit. The platoon leader should request use of the retransmission

net during all missions requiring frequency modulation (FM) communications at extended ranges.

MEDICAL PRIMARY, ALTERNATE, CONTINGENCY, AND EMERGENCY PLAN

2-265. The medical PACE plan is a communication plan that exists for a specific mission or task. The PACE plan designates the order in which an element will move through available communications systems until contact is established with the desired distant element.

2-266. Develop a PACE plan for each phase of an operation to maintain effective communication during all phases of the mission and to ensure proper coordination for patient treatment and evacuation. The PACE plan is normally set from higher to lower (brigade medical officer to medical platoon leader). The signal staff will assist in creating the PACE plan for a unit and ensure equipment is installed and operating appropriately. The medical platoon leader and PSG are responsible for ensuring an effective communication plan exists within the Role 1 BAS and that all members of the platoon understand how to use it.

2-267. A PACE plan is redundant and does not have one system relying on the other. (the alternate and contingency cannot be digital if the primary is digital). The PACE plan must ensure all units have the selected communication method. If the joint capabilities release (JCR) and/or joint battle command–platform (JBC-P) is the primary then all units must have JCR/JBC-P capabilities. Daily communication checks should be completed at designated times to ensure systems are operational and provide direction on when to switch from one to another (see table 2-8).

Table 2-8. Primary, alternate, contingency, and emergency examples

<i>Primary</i>	<i>Alternate</i>	<i>Contingency</i>	<i>Emergency</i>
JCR	HF Radio	FM (CMD NET)	Linkup Grid
JBC-P	FM (A/L NET)		
Legend:			
A/L	administrative and logistic	JBC-P	joint battle command–platform
CMD	command	JCR	joint capability release
FM	frequency modulation	NET	network
HF	high frequency		

MEDICAL COMMUNICATION FOR COMBAT CASUALTY CARE

2-268. Medical communication for combat casualty care is a medical software package fielded to operational medical forces. The system includes the theater medical information program-joint application. The theater medical information program-joint application includes software that serves as a deployed electronic health record repository and a web-based application for conducting battlefield surveillance.

2-269. The MC4 system is a theater, automated AHS support system, which links commanders, health care providers, and supporting elements, at all echelons, with integrated medical information. The MC4 system receives, stores, processes, transmits, and reports medical command and control, medical surveillance, casualty movement/tracking, medical treatment, medical situational understanding, and MEDLOG data across all levels of care. The MC4 system begins with the individual Soldier and continues throughout the health care continuum. The best way to visualize the MC4 system capability is as a piece of the Army digital computer network where all ten AHS functions have been digitized and AHS information is available to specified commands, supported units, and their personnel. The MC4 system provide Army commanders with AHS information and provides them with a seamless transition to the joint military health system environment.

2-270. Deployable medical forces use the MC4 system to gain quick, accurate access to patient histories and forward casualty resuscitation information. The system also provides units with automated tools facilitating patient and item tracking, blood management, medical reporting, and medical logistical support. Combatant commanders use the MC4 system to access medical surveillance information, resulting in enhanced medical situational awareness. Medical platoons can utilize GTA 08-10-015 as a pocket guide for MC4.

This page intentionally left blank.

Chapter 3

Army Health System Support to Operations

According to ADP 3-0, *decisive action* is the continuous, simultaneous execution of offensive, defensive, and stability operations or defense support of civil authority tasks. Army forces conduct decisive action. Commanders seize, retain, and exploit the initiative while synchronizing their actions to achieve the best effects possible. Operations conducted outside the United States and its territories simultaneously combine three elements of decisive action: offense, defense, and stability. Within the United States and its territories, decisive action combines elements of defense support of civil authority tasks and, as required, offense and defense to support homeland defense.

Contents		
		Page
SECTION I	Army Health System Support for the Offense	3-1
SECTION II	Army Health System Support for the Defense	3-14
SECTION III	Army Health System Support in Stability and Defense Support of Civil Authorities Operations	3-28
SECTION IV	Army Health System Support to Night Operations	3-30
SECTION V	Army Health System Support in Mountain Warfare and Cold Weather Operation	3-34
SECTION VI	Army Health System Support to Jungle Operations	3-45
SECTION VII	Army Health System Support in Desert Operations	3-48
SECTION VIII	Army Health System Support to Urban Operations	3-53
SECTION IX	Army Health System Support to Subterranean Operations	3-55
SECTION X	Army Health System Support to Wet Gap Crossing Operations	3-58
SECTION XI	Army Health System Support to Air Assault Operations	3-60
SECTION XII	Army Health System Support to Airborne Operations	3-64

3-1. Since there is little difference between the concepts of basic maneuvers used by the BCT configurations, except the airborne/air assault, the following discussion of medical tactics is organized by type combat maneuvers rather than by type unit supported. It should be noted here that AHS support operations tend to increase in difficulty from offense, to defense, to retrograde maneuvers with the least difficult to support being the offense.

SECTION I – ARMY HEALTH SYSTEM SUPPORT FOR THE OFFENSE

3-2. An *offensive operation* is an operation to defeat or destroy enemy forces and gain control of terrain, resources, and population centers (ADP 3-0). Offensive operations are conducted to defeat and destroy enemy forces and seize terrain, resources, and population centers. Rapid movement, deep penetrations, aggressive action, and the ability to sustain momentum regardless of counterfires and countermeasures characterize the offense.

3-3. Offensive combat operations are rapid, violent actions that remain flexible, seek enemy weak spots, and exploit successes promptly. The attack creates a fluid situation, maintains the initiative, and destroys the enemy's defensive coherence.

ARMY HEALTH SYSTEM PLANNING IN THE OFFENSE

3-4. The burden on medical resources increases due to the intensity of offensive operations and the increased distances over which support is required as a force advances. Medical units must correspondingly anticipate large numbers of casualties over a large geographic area. The employment of weapons of mass destruction will greatly increase casualties. Mass casualty situations can exceed the capabilities of organic and direct support medical assets. To prevent this from occurring, planners should anticipate this possibility and coordinate with area support medical units for additional support. Additionally, units should plan and rehearse nonstandard CASEVAC procedures. Effective management of MASCAL situations depends on established and rehearsed MASCAL plans and detailed medical planning. There are a number of other variables which can ensure the success of a unit's MASCAL response plan. These include:

- Coordination and synchronization of additional medical support and augmentation.
- Prior identification and designation of the projected CCPs.
- Quick location and clearance of the injured.
- Effective EMT.
- Accurate triage and rapid MEDEVAC, and when necessary due to resource constraints, CASEVAC, of the injured to a role of care at the next higher level.

3-5. When developing the AHS support plan to support the offense, the AHS support planner must consider many factors (ATP 4-02.55). The forms of maneuver, as well as

the threat's capabilities, influence the character of the patient workload and its time and space distribution. The analysis of this workload determines the allocation of AHS support resources and the location or relocation of Role 1 BAS.

3-6. Army Health System support for offensive operations must be responsive to several essential characteristics. As operations achieve success, the areas of casualty density move away from the supporting BAS. This causes the routes of MEDEVAC to lengthen. Heaviest patient workloads occur during disruption of the threat's main defenses, at terrain or tactical barriers, during the assault on final objectives, and during threat counterattacks. The accurate prediction of these workloads identified by the AHS support planner is essential if MEDEVAC operations are to be successful.

3-7. As advancing combat formations extend control of the battle area, supporting medical elements have the opportunity to clear the battlefield. This facilitates the acquisition of the battle injured casualties and reduces the vital time elapsed between wounding and treatment. There are two basic problems confronting the supporting medical units and MEDEVAC elements:

- First, contact with the supported units must be maintained. Responsibility for the contact follows the normal AHS support pattern that higher roles of care evacuate from lower roles of care. Contact is maintained by forward deployed air and ground evacuation resources.
- Second, the mobility of the Role 1 BAS supporting the battalion must be maintained. Prompt MEDEVAC of patients from the Role 1 BAS requires available ambulances to be echeloned well forward from the outset. Air and ground ambulance support beyond the capabilities of the Role 2 BSMC is requested from the supporting division medical company, air ambulance, and when necessary, if supported by elements of the medical company, ground ambulance. Units must also be prepared with a CASEVAC plan with designated vehicles.

3-8. In traditional combat operations, the major casualty AO is normally the zone of the main attack. As the main attack accomplishes the primary task of the maneuver element, it receives first priority in the allocation of combat power. The allocation of maneuver elements dictates roughly the areas that are likely to have the greatest casualty density.

OFFENSIVE TASKS

3-9. An offensive task is a task conducted to defeat and destroy enemy forces and seize terrain, resources, and population centers. The direct action offensive tasks are depicted in table 3-1 on page 3-4, along with key medical considerations for these types of tasks. For additional information on offensive tasks, refer to FM 3-0.

Table 3-1. Offensive tasks, purposes, and key medical considerations

<i>Offensive tasks</i>	<i>Purposes</i>	<i>Key medical considerations</i>
<ul style="list-style-type: none"> • Movement to contact. • Attack. • Exploitation. • Pursuit. 	<ul style="list-style-type: none"> • Dislocate, isolate, disrupt, and destroy enemy forces. • Seize key terrain. • Deprive the enemy of resources. • Develop intelligence. • Deceive and divert the enemy. • Create a secure environment for stability tasks. 	<ul style="list-style-type: none"> • All medical functions fully synchronized. • Medical information management to document health threat exposures and medical encounters, to report health surveillance data and information on the health of the command, and to accomplish medical regulating and patient tracking operations. • Locate, acquire, stabilize, treat, and evacuate injured or ill Soldiers from the battlefield to facilitate the operational commander's ability to exploit opportunities on the battlefield. • Trauma care, forward resuscitative care, and en route medical care to sustain the patient through medical evacuation to the appropriate role of care. • Responsive medical logistics which facilitates and sustains the treatment of patients during the fight. • Theater hospitalization to provide essential care in theater to all categories of patients.

BASIC CONSIDERATIONS

3-10. The type of offensive operation (see ATP 3-90-1) as well as enemy defensive capabilities influence the character of the patient workload and its time/space distribution. These workload factors determine the allocation of medical resources and the location and relocation of the BAS. Basic considerations which influence the use of medical units in combat operations are:

- The commander's plan (their concept of the overall operation).
- The anticipated patient load based off the casualty estimate.
- Expected areas of casualty density.
- Medical treatment and evacuation resources available.
- Terrain and road network.
- Weather conditions.
- Expected combat environment (conventional/CBRN).

3-11. The essential characteristics of AHS support in offensive operations are:

- As areas of casualty density move forward, the routes of evacuation lengthen, requiring forward displacement of medical treatment and evacuation assets.
- Heaviest patient loads occur during disruption of enemy main defenses, at terrain or tactical barriers, during assaults on final objectives, and during enemy counter attack.
- The major casualty area is the zone of the main attack. Units tasked as the main effort receive first priority in the allocation of combat power and related combat support and sustainment support. The battalion commander's allocation of forces indicates roughly the areas that are likely to have the greatest casualty density. The medical platoon leader plans for the allocation of medical support accordingly; therefore, the main effort normally receives the greatest amount of medical support.

GENERAL RULES

3-12. The Role 1 BAS is located initially as far forward in their respective areas as combat operations will allow. This tactic allows maximum use of facilities at the initial location, thus enhancing the overall effectiveness of support.

Attachment

3-13. Echelons above brigade AHS support assets normally provide unit support on an area support basis. These assets may be attached to a maneuver brigade.

Patient Acquisition

3-14. The forward movement of the battalion offsets, to a degree, the difficulties for AHS support inherent in the patient workload which usually reaches its peak in offensive operations. As advancing combat elements extend control of the battle area forward, supporting medical elements overtake patients thus facilitating acquisition of injured casualties and reducing that vital time that elapses between wounding and treatment.

Proximity and Mobility

3-15. In offensive operations, as in any ground combat involving significant movement of forces, two basic problems confront the medical platoon:

- First, proximity with supported units must be continuous.
- Second, the mobility of the Role 1 BAS must be maintained.

3-16. Responsibility for proximity follows the normal AHS support pattern, rear to front. Proximity is maintained primarily by means of the MEDEVAC elements operating within and between the several levels of medical support. Establishment of the BAS as far forward as possible to keep up with the maneuver force is a major requirement in this type operation.

Casualty Collection Points

3-17. In fast-moving situations, CCPs are normally templated along axis of advance and/or evacuation routes. Forward of the BAS, combat medics and/or combat troops place patients at CCPs which facilitates acquisition by supporting ambulance teams and reduces evacuation time. When used by the medical platoon, CCPs help preserve mobility, preclude transporting forward, and reduce evacuation time/distance to the rear. The requirement to detach some of the BAS's austere resources to continue patient treatment may, in some situations, preclude the use of a CCP at the BAS level. Casualty collection points concentrate patients for evacuation along evacuation routes. This increases the efficiency of each ambulance mission to the BAS. They also provide those units lacking organic medical support a forward area for patient disposition in high mobility situations where medical support on an area basis may not be feasible.

Prescribed Loads

3-18. The Role 1 BAS acquires the maximum permissible prescribed loads of medical supplies (Class VIII) prior to the start of the attack. The BMSO distributes medical supplies initially to the medical platoon. From there initial and replenishment supplies normally move forward via ambulances in response to verbal requests or informal requisitions for consumable items by supported treatment elements or through property exchange of nonconsumables utilized on patients. Effective operation of both these medical supply functions within the battalion is vital to the medical treatment function.

Detainees

3-19. Sick and injured detainees are treated and evacuated through normal channels insofar as is possible, but are physically segregated from operating forces and allied patients. Guards for these prisoners are provided in accordance with the battalion TACSOP and are not from AHS support personnel resources.

Civilians

3-20. The medical platoon may be required to furnish temporary emergency medical support to indigenous or displaced persons, as a humanitarian act and to prevent their interference with combat operations. The extent of this support is decided by the tactical commander; however, assistance is normally confined to emergency and advanced medical treatment. The theater Medical Rules of Eligibility will specify who is eligible for what type(s) of treatment under which conditions; the medical platoon leader, PSG, and providers should become familiar with this during MDMP.

ARMY HEALTH SYSTEM SUPPORT TO MOVEMENT TO CONTACT

3-21. *Movement to contact* is a type of offensive operation designed to develop the situation and to establish or regain contact (ADP 3-90). Medical units or elements are deployed in accordance with the overall medical plan for support of the attack prior to beginning the advance. Prior deployment of medical resources with parent and

supported units permits uninterrupted and effective AHS support of forces advancing to contact in multiple columns across a wide front and a smooth transition to support the initial phase of the offensive maneuver.

3-22. Medical evacuation support in movement to contact is keyed to the tactical plan. Prior deployment of the Role 2 BSMC ground ambulances with the maneuver battalion's organic medical platoons permits uninterrupted and effective MEDEVAC support from the BAS to the BSMC located in the BSA. Movement to contact operations are executed when there is little or no threat information. The BSMC and treatment teams from maneuver BAS in support of these operations must maintain their flexibility and be prepared to adjust AHS support once contact is established.

3-23. Normally, a covering force is provided from brigade resources. Consequently, the method of organizing unit level AHS support discussed previously applies. When the force is battalion size or larger, its medical resources usually are reinforced by elements of the Role 2 BSMC and/or EAB medical assets. Maximum use is made by the battalion's medical platoon of templated CCPs to increase effectiveness of medical support. Brigade/EAB level ambulances evacuate covering force patients directly to the BSMC. The supporting forward support MEDEVAC platoon is utilized whenever feasible and appropriate to prevent excessive, early commitment of division ambulances attached to the covering force.

3-24. Advance, flank, and rear guards normally receive AHS support through the attachment of ambulance teams, depending on the type of transport provided the supported forces. These teams evacuate patients to templated CCPs along a main axis of advance or to the nearest element (normally with a column of the main body).

3-25. A movement to contact should be supported by the medical platoon's tailgate medical support technique. This technique is used as is possible and practical. Due to the increased probability of encountering a known or likely threat and the potential to receive battle injuries, splitting the BAS into MED SEC A and MED SEC B is recommended when planning for a movement to contact mission.

3-26. When the attack is preceded by a relief in place or passage of lines, extensive liaison with medical elements of the unit in place is required to ensure continuous medical support. Generally, in a passage of lines, the participating battalion surgeons arrange for the units in place to accept the initial patients of the attacking unit in order to allow the treatment elements of the latter to maintain mobility and to initially locate farther forward to maintain proximity to the supported maneuver battalion. The ensuing combat mission of the passed unit dictates the extent to which this cross support can be provided. Medical elements of the battalion relieved in place provide the relieving battalion invaluable information about such matters as patient evacuation routes and potential sites for the Role 1 BAS, thus saving many hours of medical reconnaissance. Additional coordination might include radio frequencies and call signs, air evacuation procedures, and operation plans and SOPs.

ARMY HEALTH SYSTEM SUPPORT OF THE ATTACK

3-27. An *attack* is an offensive task that destroys or defeats enemy forces, seizes and secures terrain, or both (ADP 3-90). Attacks incorporate coordinated movement supported by fires. They may be either shaping or decisive operations. Attacks may be characterized as hasty or deliberate, depending on the time available for assessing the situation, planning, and preparing. However, based on mission variable analysis, the commander may decide to conduct an attack using only fires. An attack differs from a movement to contact because, in an attack, the commander knows part of the enemy's disposition. This knowledge enables the commander to better synchronize the attack and employ combat power more effectively in an attack than in a movement to contact.

3-28. Subordinate forms of the attack have special purposes and include the ambush, counterattack, demonstration, feint, raid, and spoiling attack. The commander's intent and the mission variables of METT-TC determine which of these forms of attack are employed. The commander can conduct each of these forms of attack, except for a raid, as either a hasty, or a deliberate operation.

3-29. The deliberate attack is based on a more detailed knowledge of the threat disposition and likely actions. The battalion's actions in contact will be more predictable than the fluid situation found in the movement to contact, exploitation, or pursuit. Specific terrain and routes/avenues of approach can be selected. At the least, units can conduct a map reconnaissance of their planned locations. While there may be AHS support requirements during the approach, the assault on the objective will produce the greatest number of casualties. Some of the AHS support considerations for the deliberate attack include:

- Higher percentage of casualties.
- Casualties will be more concentrated in time and space.
- Once the objective is secured, treatment teams can move to the objective instead of evacuating patients from the objective to the treatment teams.
- Use of air ambulance to overcome some obstacles may be required.
- Higher likelihood of wounded detainees.

ARMY HEALTH SYSTEM SUPPORT OF THE ENVELOPMENT

3-30. An *envelopment* is a form of maneuver in which an attacking force seeks to avoid the principal enemy defenses by seizing objectives behind those defenses that allow the targeted enemy force to be destroyed in their current positions (FM 3-90-1). In the envelopment, the main or enveloping attack passes around or over the threat's principal defensive positions. The purpose is to seize objectives which cut the threat's escape routes and subject him to destruction in place from flank to rear. Since the envelopment maneuver involves no direct breach of the threat's principal defensive positions, the MEDEVAC system is not confronted with a heavy workload in the opening phase. However, ambulances are positioned well forward in all roles of medical care to quickly evacuate the patients generated by suddenly occurring contact. The Role 1 BAS moves

with the battalion formation and assist with clearing the battlefield to reduce delays in treatment. After triage and treatment, the patients are evacuated to the Role 2 or 3 in the rear by supporting ground ambulances from the BSMC. When the isolated nature of the envelopment maneuver precludes prompt evacuation, the patients are carried forward with the treatment element. This must be planned for in detail and is an extreme measure when no other option is feasible. With the potential of prolonged care, the medical platoon should expect an increase in mortality from wounds. Again, nonmedical vehicles could be pressed into emergency use for this purpose. When patients must be carried forward with the enveloping forces, AHS support commanders use halts at assembly areas and phase lines to arrange combat protection for ground ambulance convoys through unsecured areas. Further, the commander should take advantage of friendly fires and suppression of threat air defenses to call for prearranged air ambulance support missions, or emergency use of medium-lift helicopter backhaul capabilities.

3-31. Since the envelopment maneuver involves no direct breach of the enemy's principal defensive positions, the medical support organization normally is not confronted with a heavy workload in the operations' opening phase. Because rapid movement and light combat are anticipated in early operations, AHS support tactics continue much the same as in the movement to contact. Ambulances are positioned well forward in both roles of care to quickly evacuate casualties generated by suddenly occurring contact without impeding early resumption of forward movement. The medical platoon moves near the rear of their respective command roles, overtakes the patients during evacuation, and reduce delay in treatment. After required treatment, if evacuation routes are open, the patient is transported to the supporting Role 3 hospital center or field hospital by corps ambulances. When the isolated nature of the envelopment maneuver precludes prompt evacuation, the patient is carried forward with the treatment element to its next site. To preclude the overloading of ambulances, less critically ill or injured patients whose immediate treatment is complete may be transferred to general purpose vehicles of the command for completion of the movement forward. Treatment teams stay abreast of the combat situation through command communication channels and reports of returning ambulance personnel. They also determine the appropriate size and time to establish treatment teams based on the tactical situation. When patients must be carried forward with the enveloping forces, medical commanders and platoon leaders utilize halts at assembly areas and phase lines to arrange combat protection for convoys of ground ambulances evacuating patients to supporting Role 3 hospital centers or field hospitals or to call-in prearranged air ambulance support missions to preserve the mobility of the forces' medical elements. Appropriate general support EAB medical units may be attached to the brigade for the duration of the envelopment operation.

3-32. Normal medical supply and maintenance procedures may be modified by increasing the use of air ambulances to move medical supplies forward, to evacuate damaged equipment over the extended distances and to circumvent unsecured ground routes.

3-33. Medical units supporting an envelopment must not be immobilized by detainees or nonmilitary patient workloads. If such workloads are anticipated, appropriate reinforcement by BSMC medical resources should be requested and provided in advance

by EAB AHS support forces. Commitment of Role 2 BSMC and/or EAB in support of the brigade to this mission should be limited to the extent of organizing emergency self-support in the affected groups.

3-34. When the maneuver includes vertical envelopment by an airborne or air assault force, the organic brigade medical elements accompany the force through insertion by parachute or helicopter. When an airborne or air assault force is employed in the vertical envelopment, the BSMC medical elements, which are transportable by light or medium helicopters, accompany the airborne or air assault force. Anticipated delay in linkup may require commitment of additional treatment and holding facilities to the airborne or air assault force. In airborne operations, evacuation is provided by United States Air Force aircraft until the linkup is made, whereas in air assault operations, evacuation of patients is provided mainly by Army aeromedical ambulances. Air assault operations in isolated LZs may require complete reliance on Army AE or patient movement by other Army nonmedical aircraft returning from the airhead.

ARMY HEALTH SYSTEM SUPPORT OF THE TURNING MOVEMENT

3-35. A *turning movement* is a variation of the envelopment in which the attacking force passes around or over the threat's principal defense positions to secure objectives deep in the threat's rear; thus, forcing the threat to abandon their position or divert major forces to meet the threat (FM 3-90-1). As stated above, the turning movement is a variant to the envelopment in which the attacker attempts to avoid the defense entirely. Rather, the attacker seeks to secure key terrain deep in the threat's rear and along their line of communication. Faced with a major threat to their rear, the threat is "turned" out of their defensive positions and forced to attack rearward at a disadvantage. Medical evacuation support to the turning movement is provided basically in the same manner as to the envelopment. As the operation is conducted in the threat's support area, line of communication and evacuation routes could be unsecured, resulting in delays in resupply and evacuation.

ARMY HEALTH SYSTEM SUPPORT TO PENETRATION

3-36. A *penetration* is a form of maneuver in which an attacking force seeks to rupture enemy defenses on a narrow front to disrupt the defensive system (FM 3-90-1). Listed below are the three main purposes of a penetration:

- To breach the enemy's main defensive position.
- To widen the gap created to secure the flanks by enveloping one or both of the newly exposed flanks.
- To seize the objective with its associated subsequent exploitation.

ARMY HEALTH SYSTEM SUPPORT TO A BREACH

3-37. A *breach*, is a tactical mission task in which the unit employs all available means to break through or establish a passage through an enemy defense, obstacle, minefield,

or fortification (FM 3-90-1). During breach operations, plans must be in place for clearing casualties off the battlefield since increased number of casualties should be anticipated. Each company team requires an armored ambulance for CASEVAC. If the engineer company assigned to a ABCT is the breaching force, it must have one armored ambulance in direct support. The BAS splits into two treatment teams, alpha and bravo. With the addition of the two BSMC ambulances the treatment teams get one BSMC ambulance each and now have a MEDEVAC capability. Their title is now MED SEC A and MED SEC B. The medical sections pre-position with the battalion prior to LD. Medical section bravo moves forward behind one of the company teams. Medical section alpha follows the battalion formation. The AXP with a treatment team from the Role 2 BSMC must be integrated into the battalion scheme of maneuver. Without the AXP, the battalion medical elements will lose their ability to move as patients collect at the medical sections alpha and bravo. The AXP moves forward with the battalion combat trains. The battalion combat trains should move within four kilometers (2.4 miles) but no more than 10 kilometers (6.2 miles) behind the lead elements of the battalion. Once the breach is completed, the medical section alpha moves through the breach to the other side, while the medical section bravo moves to the position previously occupied by the alpha. The AXP moves forward to the position previously occupied by the bravo. Patient acquisition starts slowly but becomes more rapid as the attack progresses. Evacuation routes lengthen as the operation progresses. Heavy suppressive fires which can evoke heavy return fire often precede the obstacle reduction. These threat fires could modify the decision to place evacuation assets as far forward as possible. The BSMC can reinforce the breach force medical elements. Patient evacuation could be slow and difficult due to a bottleneck at the point of breach. While conducting breaching operation, MEDEVAC support problems multiply when some combat units remain near the point of breach. This is done to hold or widen the breach lanes while the bulk of maneuver elements exploit or pursue the threat. Treatment elements are placed near each end of the breach lane; ground evacuation cannot take place across an avenue of heavy combat traffic. Because of the heavy traffic, the breach area is normally a target for both conventional weapons and weapons of mass destruction. The trigger to push a medical section or the entire BAS through the point of breach and where they will go must be identified in the OPORD.

3-38. Of all the tactical mission tasks, breaching normally produces the heaviest medical workload. Patient collection starts slowly but will become more rapid as the attack progresses. Likewise, evacuation routes initially lengthen relatively slowly. Obstacle reduction is usually preceded by heavy suppressive artillery fires which will probably evoke heavy return fire from the enemy. Heavy fire from the enemy may modify the basic requirement of placing the Role 1 BAS and ambulances as far forward as possible. Patient evacuation may be slow and difficult because of damage to roads or the inaccessibility of patients due to heavy combat conditions. The use of available Army aviation assets will expedite movement of patients. A tendency to establish large treatment facilities to accommodate a heavy initial patient workload must be tempered by the possible assault of enemy defensive positions and rapid transition to exploitation and pursuit operations. When operations require wide dispersion of combat elements, the medical platoon leader, in conjunction with their field surgeon and PA may establish company aid posts in addition to CCPs. The senior combat medic supporting the

company usually operates the aid post, performing preliminary sorting and emergency care of all patients and returning to duty those patients with minor illness or injury whom they can treat definitively. When dispersed companies are isolated temporarily from their support, the combat medics must provide continuing emergency care of patients awaiting evacuation.

3-39. Some combat units of the battalion may be required to remain near the point of breach to hold or widen the breach lanes through obstacles while the bulk of battalion and/or brigade forces exploit or pursue. Appropriate supporting medical elements must be placed near each end of the breach lane because evacuation cannot logically take place across an avenue of heavy combat traffic. In addition to this extremely heavy traffic through the lane, the area is very likely a target for enemy attack by conventional, nuclear, or chemical weapons. Medical elements should remain clear of the entry and exit lane for their own protection and for the protection of their patients. Brigade support medical companies and EAB medical elements in support of the BCT placed in support of these combat units should be as limited as feasible, and every effort must be made to keep the BSMC free of patients by early transfer to supporting EAB medical units to enhance mobility. The BSMC must be prepared to displace forward rapidly as soon as supported combat units are relieved of the secondary attack mission and close up to battalion pursuit units.

ARMY HEALTH SYSTEM SUPPORT IN INFILTRATION

3-40. An *infiltration* is a form of maneuver in which an attacking force conducts undetected movement through or into an area occupied by enemy forces to occupy a position of advantage behind those enemy positions while exposing only small elements to enemy defensive fires (FM 3-90-1). The battalion can attack after infiltration or use it as a means of obtaining intelligence and harassing the threat. Though it is not restricted to small-units or dismounted actions, the battalion employs these techniques with a portion of its units, in conjunction with offensive operations conducted by the remainder of its units.

3-41. Medical support of infiltration is restricted by the amount of medical equipment, supplies and transportation which can be introduced into the attack area. No deployment of Role 1 BAS treatment teams without their organic transportation should be attempted. Elements of unit level medical support should be accompanied by all their organic vehicles, but ambulances receive priority for deployment. It may be feasible to manually carry enough BAS equipment into the attack area to provide EMT but mobility is then virtually nonexistent. When the element is committed without its ambulances, patients are evacuated to the treatment team exclusively by aid and litter teams, requiring reinforcement of the Role 1 BAS by Role 2 BSMC medical personnel or improvisation of litter teams using combat troops if approved by the combatant commander. Patient evacuation from the medical platoon treatment teams and medical resupply to the force may also be provided by litter bearers, depending on distances and degree of secrecy required.

3-42. When airborne and air assault forces are used, infiltrating elements can land at various points within the threat's support area and proceed on foot to designated attack

positions. As in surface movement, the amount of medical equipment taken could be limited. In airborne operations, the evacuation of patients will be by litter bearers or medical platoon ground ambulances to CCPs or the BAS and then by BSMC ambulances to the Role 2 BSMC. In air assault operations, the evacuation is by litter bearers to CCPs or the BAS and then by air ambulances to the BSMC or farther to a Role 3 hospital center of field hospital if feasible. Once the combat element begins the assault on the objective, secrecy is no longer paramount and its isolated location requires AHS support characteristic to airborne and air assault operations until ground linkup.

3-43. Noise, light, and litter discipline during evacuation in an infiltration depends on how the casualty was wounded. Disease and nonbattle injuries Soldiers may not have been noticed by the enemy. If the casualty is a battle injury, the enemy has already detected that element. Once the enemy has detected and engaged the force, causing casualties, maximum allowable use of standard and nonstandard evacuation platforms should be used. This will increase lift capabilities and save time and Soldiers' lives. Patient evacuation from the BAS and medical resupply of the force may be provided by litter bearers, depending upon distances and degree of secrecy required.

ARMY HEALTH SYSTEM SUPPORT OF EXPLOITATION AND PURSUIT

3-44. An *exploitation* is a type of offensive operation that usually follows a successful attack and is designed to disorganize the enemy in depth (JP 2-01.3). A *pursuit* is an offensive task designed to catch or cut off a hostile force attempting to escape, with the aim of destroying it (ADP 3-90). Medical evacuation support of exploitation and pursuit operations resemble those discussed for the envelopment. Since exploitation and pursuit operations can rarely be planned in detail, evacuation operations must adhere to TACSOP and innovative C2. These actions are often characterized by—

- Fewer casualties.
- Decentralized operations.
- Unsecured ground evacuation routes.
- Exceptionally long distances for evacuation.
- Increased reliance on convoys and air ambulances.
- More difficult communications.

3-45. Exploitation is the following up of gains to take full advantage of success in battle. It is a phase of the offensive that destroys the enemy's ability to reconstitute an organized defense or to withdraw in good order in the face of threatened disaster. The pursuit may follow the exploitation. The pursuit differs from the exploitation in that its primary function is to complete the destruction of the enemy force which is in the process of disengagement. Because combat units involved in exploitation and pursuit employ similar tactics as in envelopments and turning movements, AHS support operations resemble those discussed for the envelopment. Control of supporting EAB medical units frequently is decentralized at brigade level in these type actions, and insecure ground routes normally force reliance on evacuation by intermittent ground ambulance convoy or by Army air ambulances. Since exploitation and pursuit can rarely be planned in

detail, medical operations adhere primarily to existing SOPs with continuing adjustments by platoon leader, BSB SPO medical staff, and brigade surgeon. Successful improvisation of medical support to accommodate rapid movements requires especially effective communication and uninterrupted contact with the supporting medical unit.

ARMY HEALTH SYSTEM SUPPORT OF THE RECONNAISSANCE IN FORCE

3-46. The reconnaissance in force is an attack to discover and test the enemy's position and strength or to develop other intelligence data. The brigade usually probes with multiple maneuver units of limited size, retaining sufficient reserves to quickly exploit discovered enemy weaknesses. Army Health System support operations follow closely those discussed for the movement to contact. Ambulance assets are positioned well forward both at unit and brigade levels to ensure prompt acquisition and evacuation of casualties. Whenever possible, this positioning takes place during the hours of darkness and the ambulances may be camouflaged to enhance secrecy. The positioning of ambulances is an indication to the enemy that an attack is imminent due to the forward placement of the medical support. The medical platoon is not established until a significant patient workload develops. Patients received at treatment teams of reconnoitering units are evacuated to the Role 2 BSMC as early as practicable or are carried forward with the force until a suitable opportunity for evacuation presents itself. Maximum possible use of air ambulances may be made to support the reconnoitering force due to extended distances covered and to overcome potentially insecure ground evacuation routes.

SECTION II – ARMY HEALTH SYSTEM SUPPORT FOR THE DEFENSE

3-47. A *defensive operation* is an operation to defeat an enemy attack, gain time, economize forces, and develop conditions favorable for offensive or stability operations (ADP 3-0). Defensive operations combine static and dynamic elements, supported by deep attack. This allows the defense to defeat the offense's momentum, present them with the unexpected, defeat their combined-arms, and gain the initiative. There are three defensive tasks: area defense, mobile defense, and retrograde.

- The *area defense* is a type of defensive operation that concentrates on denying enemy forces access to designated terrain for a specific time rather than destroying the enemy outright (ADP 3-90).
- The *mobile defense* is a type of defensive operation that concentrates on the destruction or defeat of the enemy through a decisive attack by a striking force (ADP 3-90).
- The *retrograde* is a type of defensive operation that involves organized movement away from the enemy (ADP 3-90). Delay, withdrawal, and retirement are the three forms of retrograde operation.

3-48. Within each defensive tasks there are subordinate forms of the defense that have special purposes and have their own unique medical planning considerations. The three forms are:

- Defense of a linear obstacle.
- Perimeter defense.
- Reverse slope defense.

3-49. The defense is a temporary measure adopted until a force can assume or resume offensive operations. Defensive operations are actions to prevent, resist, repulse, or destroy an enemy attack. The defense is undertaken to develop more favorable conditions for subsequent offensive operations, economize forces in one area in order to apply decisive force elsewhere, destroy or trap a hostile force, deny an enemy entrance to an area or reduce enemy capability with minimum losses to friendly forces. The defense denies success to an attacking enemy (see ATP 3-90-1). Defensive operations are also used to—

- Control essential terrain.
- Preserve forces, facilities, installations, and activities.
- Retain tactical, strategic or political objectives.
- Gain time.
- Force the enemy to mass so that they are more vulnerable to firepower.

ARMY HEALTH SYSTEM PLANNING IN THE DEFENSE

3-50. Defensive options form a continuum from absolutely static defense (strong points) designed exclusively to retain terrain to a wholly dynamic defense that focuses only on the enemy. The defense and enemy offensive capabilities influence the character of the patient workload and its time/space distribution which, in turn, determine allocation of medical resources and location of the BAS. Utilization of medical units is influenced by the same basic considerations discussed previously in connection with offensive operations.

3-51. Army Health System support provided for the defense may reflect lower casualty rates, but threat actions and the maneuver of combat forces complicate forward area patient acquisition. Medical platoon personnel are permitted less time to reach the patients, complete vital TCCC, and remove them from the battle site. Increased casualties among exposed medical platoon personnel further reduce medical treatment and evacuation capabilities. The depth and dispersion of the defense create significant time and distance problems for evacuation assets. Combat elements could be forced to withdraw while carrying their remaining patients to the rear. The threat exercises the initiative early in the operation, which could preclude accurate prediction of initial areas of casualty density. This makes the effective integration of air assets into the MEDEVAC plan essential. The use of air ambulances must be coordinated, and they are normally positioned in the BSA.

DEFENSIVE TASKS

3-52. Army Health System support operations for defensive tasks are similar to those for offensive tasks; however, normally the timeframe in which the tasks must be conducted is compressed. The only means for increasing the mobility of AHS support units is to evacuate the patients they are holding. When it is anticipated that rapid shifts will occur in the OE, AHS support units must evacuate patients from the potentially affected units to ensure their agility and to enhance their capacity for newly arriving patients. Table 3-2 depicts the defensive tasks, purposes, and key medical considerations when preparing for these types of tasks.

Table 3-2. Defensive tasks, purposes, and key medical considerations

<i>Defensive tasks</i>	<i>Purposes</i>	<i>Key medical considerations</i>
<ul style="list-style-type: none"> • Mobile defense. • Area defense. • Retrograde. 	<ul style="list-style-type: none"> • Deter or defeat enemy offense. • Gain time. • Achieve economy of force. • Retain key terrain. • Protect the populace, critical assets, and infrastructure. • Develop intelligence. 	<ul style="list-style-type: none"> • All medical functions fully synchronized. • Medical information management to document health threat exposures and medical encounters, to report health surveillance data and information on the health of the command, and to accomplish medical regulating and patient tracking operations. • Emphasis is placed on the rapid acquisition, stabilization, and evacuation of patients generated by units in contact. This enhances the mobility of supporting Army Health System units and facilitates the commander's ability to exploit opportunities and leverage the momentum to mount a counterattack or perform other maneuvers. • Responsive medical logistics which facilitates and sustains the treatment of patients during the fight. • Theater hospitalization to provide essential care in theater to all categories of patients.

ARMY HEALTH SYSTEM IN THE DEFENSE

3-53. Generally, medical support of defensive operations are more difficult than in the offensive. Patient loads reflect a lower casualty rate, but forward area acquisition of patients is complicated by enemy action and the initial direction of maneuver to the rear. Medical platoon personnel are permitted much less time to reach the patient, complete the vital EMT and remove him from the battle site. Increased casualties among exposed medical platoon personnel will further reduce medical treatment and evacuation capability.

3-54. Heaviest patient workloads, including those produced by enemy artillery, rockets, and CBRN weapons, may be expected during the preparation and/or initial phase of enemy attack and in the counterattack phase. The enemy attack may disrupt ground and air communications routes and delay evacuation of patients to and from treatment teams. Stockpiling medical supplies in individual fighting positions is a technique used in defense to lessen the burden on the combat medic's individual load and promotes robust self-aid/buddy aid and care provided by the CLS.

3-55. Because reserve maneuver elements play a decisive role in defense, location of treatment teams must not complicate the maneuver of reserves. Further, EAB medical units commensurate with the size and composition of the reserve are initially withheld from operations for immediate commitment to support of the reserve.

3-56. The depth and dispersion of the defense create significant time and distance problems in patient evacuation support to security and fixing forces. Security forces may be forced to withdraw while simultaneously carrying their remaining patients to the rear. The use of Army air ambulances will expedite the evacuation of these patients.

3-57. The probability of initial enemy penetration requires medical treatment teams be located farther to the rear than in the offense.

3-58. The enemy exercises the initiative early in the operation, which precludes accurate prediction of initial areas of casualty density. The EAB medical assets in support of the brigade achieve the flexibility needed to support defensive operations at a location of the enemy's choosing by being assigned direct or general support missions instead of direct attachment to the battalions.

3-59. Medical assets in support of the brigade are established and kept as mobile as possible by frequent and continuous evacuation of patients. Mobility is also enhanced by establishing the minimum size Role 1 through 3 necessary to cope with the patient load.

ARMY HEALTH SYSTEM SUPPORT OF THE AREA DEFENSE

3-60. In a defensive battle, commanders generally use tanks and overwatching long-range antitank weapons. They use short-range antitank and other infantry weapons in urban, wooded, or rugged areas to defend static positions. Each commander decides how to task organize, depending on their battle plans. On some occasions the brigade commander may decide to use CABs without cross-reinforcing to make special use of the capabilities of each. For example, they may position a CAB (Infantry) in a cluster of small villages all within supporting distance of each other across an avenue of approach. The CAB (Armored) forms the dynamic element, counterattacking the flank or rear of the enemy force as it encounters the dug-in CAB (Infantry). Strong points are the most static elements of a defense. A *strong point* is a heavily fortified battle position tied to a natural or reinforcing obstacle to create an anchor for the defense or to deny the enemy decisive or key terrain (ADP 3-90). Strong points can be located on terrain features critical to the defense or at a bottleneck formed by natural terrain or manmade obstacles.

3-61. Strong points astride or along avenues of approach in small urban areas may make it possible to halt a superior force for an extensive period of time. When nuclear or chemical weapons are employed, strong points must be well camouflaged and protected, or forces must occupy them just before the enemy's arrival. To be effective, the strong point must surprise the enemy. It must congest and limit their maneuver. It can set up a counterattack. Commanders can extricate the force in the strong point after it has accomplished its mission and before enemy follow-on forces arrive.

3-62. Whatever the defensive techniques, the overall scheme should maximize maneuver and offensive tactics. When the enemy has committed their forces, the defender should seize the initiative and counterattack over familiar ground protected by their own positions. Units can destroy a halted, disorganized enemy.

MEDICAL SUPPORT OF COVERING FORCES

3-63. Forces used in the defense may include the covering force, observation posts, listening posts, patrols, flank guards, and support area security forces. The BCT's highly mobile security forces must have enough combat power to adequately screen the forward edge of the battle area (FEBA) and force early deployment of the enemy's main force. The brigade's cavalry squadron, reinforced by fires, military intelligence, engineer and aviation elements, normally performs the security mission. The medical support of the security force will depend on its ultimate size, organization and mission.

3-64. The covering force presents a particularly challenging AHS support mission. The cover force requires fluid, rapidly changing maneuvers to identify the nature, size, and direction of probable enemy attacks. Lines of evacuation and logistical support are long and unsecure, and the nature of the mission creates expectations of high casualty rates. Patient evacuation and resupply will be accomplished by air ambulance whenever the tactical situation permits. When this is not possible, the evacuation of their patients may be best accomplished by the medical platoon being reinforced with ambulances and crews that evacuate patients to prearranged CCPs. At these collection points, patients are transferred to Role 2 BSMC and/or EAB ambulance assets and shuttled back to the BSMC. This allows the ambulances evacuating the patients from the covering force to make the transfer and quickly turn around to support the medical platoons again reducing the risk of the tactical situation changing and the medical platoon relocating during their absence. It also allows the evacuation system to take full advantage of short periods of secure, forward evacuation routes. The medical platoon and company CCPs may need to be augmented with extra medical personnel and expertise in order to provide prolonged care for the casualties during extended periods when patient evacuation is not possible.

3-65. Unit medical support elements of security forces establish treatment teams or provide tailgate medicine support to maintain maximum mobility. Ambulances are initially deployed well forward to promptly clear casualties from the combat units. The covering force's medical platoon headquarters section remains in close contact with operations of attached aviation elements, using their resources for patient backhaul capabilities. This is done in lieu of long ground ambulance trips with casualties who

need little or no medical attention en route. Early evacuation of patients from treatment teams is the rule to help preserve station mobility for rearward displacement.

3-66. Brigade support medical company ambulances may operate under control of the covering force medical platoon. Because the supporting Role 2 BSMC is established up to 25 kilometers (15.5 miles) to the rear of main defensive forces, evacuation distances are lengthy. The size of covering forces and their relatively high casualty rate demand heavy commitment of Role 2 BSMC and/or EAB ambulance resources to their support. Mission, enemy, terrain, troops available, time, and civilian considerations dependent, the responsiveness of the ambulance assets committed to this mission may be improved by maximum use of supporting air ambulances of the forward MEDEVAC platoon for evacuation of more seriously ill or injured patients and shuttling the balance of patients to the nearest treatment team behind the FEBA, cutting ground ambulance turnaround time.

3-67. The wide dispersion of units and the manner in which they withdraw make collection of patients difficult. When covering forces withdraw, patients are transported to the rear by the medical element which acquired them. If not accompanied by an ambulance, the company combat medics arrange transportation for their patients with the commander of the supported company. Seriously ill or injured patients still located in the Role 1 BAS are given priority for evacuation by the withdrawing aviation elements. Ground ambulances, augmented by CASEVAC vehicles as required, may transport the remainder of the patients. No intraforce evacuation is attempted during this maneuver. Patients are carried with the force to its destination or are transferred to other brigade and/or division-level EAB supporting Role 2 or 3 facility en route as their condition dictates.

ARMY HEALTH SYSTEM SUPPORT OF THE MAIN OPERATIONS AREA

3-68. In the defense, units are task-organized and employed according to their weapons' system capabilities to counter maneuver against the enemy's attack. As the covering force delays and identifies the strength, location, and direction of the main enemy attack, the brigade commanders will rapidly assign their battalions to defend within their AO. In the conduct of the defense, it is anticipated that a strong and determined enemy can penetrate the forward defense areas. The battalion will avoid being fixed by the enemy forces through maneuver to successive battle positions while inflicting heavy losses on the enemy.

3-69. The highly fluid nature of this battlefield makes the location and organization of company and battalion trains temporary and unpredictable. The company CCP and the medical platoon treatment teams are routinely located within these areas. In this lethal environment there may be extended periods of time when there are no safe ground or air evacuation routes to the rear and the coordination of patient evacuation is slow and tedious at best. Ground ambulance sorties may have to move under the same protection offered to the ammunition and fuel convoys. Patients may have to be transported to templated CCP further to the rear or the Role 2 BSMC/EAB medical assets by CASEVAC vehicles as well as MEDEVAC vehicles to be further sorted, stabilized, and evacuated. The net result of the delays in CASEVAC is a need for augmentation of the medical platoon personnel, evacuation assets, and medical supplies at battalion and

company level. These resources must be requested via the BMSO and /or MEDLOG officer in the BSB SPO or division surgeon's section and drawn from division and/or corps assets.

3-70. The mission and employment of the defending forces requires modification of normal division-level EAB AHS support methods. Echelons above brigade units in support of a BCT are located to the rear of the brigade area of operation. Initial commitment of Role 2 BSMC and/or EAB ambulances in support of medical platoons is minimal. Lengthy, unsecure ground routes may permit patient evacuation only at periodic intervals, and/or by EAB ambulance augmentation, as requested by the medical platoon leader or surgeon section staff members of the defending forces. Brigade support medical company medical resources are normally placed in direct support of brigades; however, in this environment the EAB medical assets may be maintained in a more general support role for the entire division to maintain a high degree of mobility and to support the areas of casualty density as the battle develops.

ARMY HEALTH SYSTEM SUPPORT OF THE MOBILE DEFENSE

3-71. The mobile defense focuses on defeating or destroying the enemy by allowing enemy forces to advance to a point where they are exposed to a decisive counterattack by the striking force. The *striking force* is a dedicated counterattack force in a mobile defense constituted with the bulk of available combat power (ADP 3-90). A *fixing force* is a force designated to supplement the striking force by preventing the enemy from moving from a specific area for a specific time (ADP 3-90). The commander uses the fixing force to hold attacking enemy forces in position, to help channel attacking enemy forces into ambush areas, and to retain areas from which to launch the striking force.

3-72. A mobile defense requires an AO with considerable depth. Commander's shape their battlefields causing enemy forces to overextend their lines of communication expose their flanks, and dissipate their combat power. Commanders move friendly forces around and behind enemy forces to cut off and destroy them. Divisions and larger echelon formations normally execute mobile defenses. Brigade combat teams and maneuver battalions participate in a mobile defense as part of a fixing force or a striking force.

3-73. Army Health System support to the mobile defense is one of the most difficult tasks to accomplish. The nature of the mobile defense calls for units to be constantly on the move. Medical units supporting a mobile defense have to bring all six AHS principles to play. Medical platoons should have detailed procedures in their TACSOP.

ARMY HEALTH SYSTEM SUPPORT TO RETROGRADE OPERATIONS

3-74. The enemy may force retrograde operations, or a commander may execute them voluntarily. The higher commander of the force executing the retrograde must approve the operation before its initiation in either case. The retrograde is a transitional

operation; it is not conducted in isolation. It is part of a larger maneuver scheme designed to regain the initiative and defeat the enemy.

3-75. A retrograde operation may be forced by enemy action or may be executed voluntarily. Reasons for conducting a retrograde operation include the following: to disengage from battle, to avoid combat in a disadvantageous situation, to draw the enemy into an unfavorable situation, to gain time without fighting a decisive engagement, to conform to the movement of friendly troops, and to permit the employment of a portion of the command elsewhere. In executing the planned movement away from the enemy, the division employs a combination of offensive, defensive, and delaying tactics supported by extensive artillery and/or nuclear fires. Maneuver elements in the BCT are frequently deployed over an extended front, and conduct a series of independent unit actions within the framework of a detailed, overall plan. The specific retrograde maneuver may be withdrawal, delaying action, or retirement.

MEDICAL CONSIDERATIONS

3-76. The medical problems involved in retrograde movements may vary widely depending on the operation, the enemy reaction, and the current tactical situation. Firm rules that apply equally to all types of retrograde operations are impossible to establish, but certain factors should be considered in the medical planning of all retrograde operations.

3-77. The AHS support requirements for retrogrades can vary widely depending upon the tactical plan, the threat reaction, and the METT-TC factors. Considerations include:

- Requirement for maximum security and secrecy in movement.
- Influence of refugee movement conducted in friendly territory, which could impede MEDEVAC missions.
- Integration of evacuation routes and obstacle plans.
- Difficulties in controlling and coordinating movements of the force that could produce lucrative targets for the threat.
- Movements at night or during periods of limited visibility.
- Time and means available to remove patients from the battlefield.
- Medical evacuation routes required for the movement of troops and materiel. This causes patient evacuation in retrograde movements to be more difficult than in any other type of operation. The threat could disrupt C2. Successful MEDEVAC requires including ambulances on the priority list for movement; providing for the transportation of the slightly wounded in cargo vehicles; and providing guidance to subordinate commanders defining their responsibilities in collecting and evacuating patients. Special emphasis must be placed on the triage of patients and consideration given to the type of transportation assets available for evacuation.
- Decisions concerning patients left behind. When the patient load exceeds the means to move them, the tactical commander must make the decision as to whether patients are to be left behind. The medical platoon leadership keeps the battalion commander informed so they can make timely decisions.

Medical platoon personnel and supplies must be left with patients who cannot be evacuated, refer to ATP 4-02.2 for additional information. Every effort will be made to avoid this solution.

SPECIAL CONSIDERATIONS

3-78. Factors to consider in the requirement for maximum security and secrecy in movement:

- The influence of civilian evacuation which may impede medical movements in connection with operations conducted in friendly territory.
- Difficulties in controlling and coordinating movements of the force which may produce lucrative artillery targets for the enemy.
- Time is a critical factor. The number of casualties removed from any battlefield is dependent upon the time and means available. In stable situations and in the advance, time is important only as it affects the physical well-being of the injured. In retrograde operations, time is more important. As available time decreases, the medical planners, platoon leaders, and surgeons at all levels must closely evaluate the capability to collect, treat, and evacuate all patients.

EVACUATION

3-79. Evacuation routes will be required for the movement of casualties and materiel. Patient evacuation in retrograde movements are considered to be more difficult than in any other type of operation. Command and control communications may be disrupted by the enemy. The measures taken to counteract factors impeding evacuation during retrograde movements are beyond the scope of medical authority. For successful evacuation, the appropriate commander must take positive action. Successful evacuation requires the inclusion of ambulances on the list of priorities for movement, provision for the transportation of slightly wounded in cargo vehicles and directives to subordinate commanders defining responsibilities in the collection and evacuation of casualties.

3-80. Mobility of medical companies will be enhanced by evacuating patients as their condition warrants directly from medical platoons to hospitals whenever necessary.

3-81. Special emphasis must be placed on the triage of patients and consideration must be given to the type of transportation available for evacuation. Seriously wounded patients should be evacuated by the fastest and most comfortable means. Proper triage and rapid evacuation of patients will lessen the need for completely establishing the BAS. This should be a coordinated effort between the air and ground ambulance units and the medical planners.

3-82. When the patient load exceeds the means to move them, the tactical commander must make the decision as to whether or not patients are to be left behind. The medical platoon leadership or brigade surgeon must ensure that the tactical commander is kept informed about the need to reach a timely decision in this regard. Medical platoon personnel and supplies must be left with patients who cannot be evacuated.

LOCATION OF ROLES OF CARE

3-83. During retrograde movement, the Role 1 BAS usually displace and hold patients for a short period of time. Locations for successive positions (from forward to rear areas) for the BAS, Role 2 BSMC or Role 3 hospital center or field hospital involved must be planned in advance. Since the general direction of movement is toward these medical units, initial locations may be placed farther to the rear than in other types of operations. For continuity of support the next rearward location should always be occupied by a medical unit prepared to function before the forward location is closed.

Displacement

3-84. Frequency of displacement will be determined by the rate of movement and the distance involved. The Role 1 BAS must be displaced before there is danger of involvement in the action of forces conducting a retrograde movement.

Future Operations

3-85. Operations to be undertaken at the conclusion of the retrograde movement must be considered when planning medical support. This consideration is most important in preparing for later phases of movement.

Passage of Lines

3-86. When the retrograde operations involves a rearward passage of lines, detailed advanced planning between Role 1 BASs of passing and passed BCTs and/or battalions is essential. The surgeon of the brigade or battalion medical platoon leader and battalion surgeon being passed provides important information as to the location of the brigade and battalion forces, the BAS, and evacuation routes within the area. The two units develop a coordinated plan for joint support of any abnormal patient workload which may develop in either brigade and/or battalion during the passage of lines. Overconcentration of forces, which presents a lucrative target to the enemy, is a primary hazard in the passage of lines. The establishment of the brigade Role 2 BSMC or battalion Role 1 BAS is limited to cope with expected casualty workloads. In planning the location of the BAS, detailed attention is given to selection of sites which offer the enemy the least amount of information as to location of major elements of either brigade or battalion. The medical support plans of both units during the passage of lines usually stipulates that the passing unit transports its own patients to the rear, with the exception of critically ill or injured patients who may be passed to the unit in place to expedite their treatment. This technique is employed to preserve the mobility of the medical support in the unit which is to assume the covering or defensive role.

Mobility

3-87. In retrograde operations more than any other maneuver, mobility of the BAS must be maintained. This is necessary to permit the rapid movement of these facilities without the need to abandon patients. The battalion-level medical assets can assist in maintaining this mobility by keeping the medical platoon free of patient accumulation and by keeping the BSMC patient loads low by coordinating with the supporting medical elements and by recognizing any increase in casualty loads early.

ARMY HEALTH SYSTEM SUPPORT OF DELAYING OPERATIONS

3-88. A *delay* is when a force under pressure trades space for time by slowing down the enemy's momentum and inflicting maximum damage on enemy forces without becoming decisively engaged (ADP 3-90). Delaying operations occur when forces are insufficient to attack or to defend and when the defensive plan calls for drawing the attacker into an unfavorable situation. They normally gain time to—

- Reestablish the defense.
- Cover a defending or withdrawing unit.
- Protect a friendly unit's flank.
- Participate in an economy of force effort.

3-89. Delays gain time by forcing the enemy to repeatedly concentrate against successive battle positions. As enemy units begin to deploy for the attack, the delaying force withdraws to new battle positions. The enemy must repeat the same time-consuming deployment at the next position. At the same time, deep attack slows the enemy's advance and prevents him from massing overwhelming combat power against the delaying force.

3-90. The usual maneuver of delay of successive positions employs the major force on delay positions across a broad front. Delaying brigades split their combat power, moving their less mobile forces directly to the next delay position while a tank-heavy force normally covers the initial displacement and fights a delaying action to the new position. Each brigade maintains a small reserve to conduct limited objective attacks which assist in extricating hard-pressed delaying forces. Unit-level AHS support is provided to the major force essentially as discussed for medical support of withdrawal. Because the brigade reserve is likely to be committed to assist a unit which is being subjected to severe enemy pressure, its support should include medical platoon elements of minimum size in addition to normal company combat medics and ambulance support, making the reserve force self-sufficient in unit-level AHS support. A division's EAB medical support may require continuous operation of two Role 2 medical companies, area support, each in direct support of one brigade, to adequately service the wide front.

3-91. The less frequently used tactic of delay on alternate positions, normally employed on a narrow front, and provides for leapfrogging major units (brigades) rearward. The foremost brigade delays back to the next succeeding delay position, prepared and occupied by a second brigade. Medical platoons establish facilities of minimum size and split for rearward displacement. Ambulance support is developed forward to give as extensive lateral coverage as possible to expedite patient evacuation from units in contact. One medical company provides adequate support for the brigade in contact, and medical company leapfrog rearward as the brigades displace. Extra EAB ambulances to support the brigade in contact are deployed both at medical platoons and at the medical company to expedite evacuation and assist in moving casualties when the station displaces.

ARMY HEALTH SYSTEM SUPPORT OF WITHDRAWAL

3-92. *Withdraw* is to disengage from an enemy force and move in a direction away from the enemy (ADP 3-90). It may be forced by enemy pressure, or it may be conducted without enemy pressure.

3-93. Although the deployed force disengages from the enemy, contact is maintained by security elements while the main forces move directly to the rear, from march columns and move to predesignated locations. In the preferred withdrawal conducted at night not under enemy pressure, the maneuver elements in contact with the enemy must roll to the rear. This is usually done by designating a detachment of combat forces to remain in contact with the enemy. A *detachment left in contact* is an element left in contact as part of the previously designated (usually rear) security force while the main body conducts its withdrawal (FM 3-90.1). This detachment is designed to prevent giving the enemy any indication that a withdrawal is being executed and provides some protection to the withdrawing force. The detachment left in contact (DLIC) is generally made up of one-third of the riflemen and one-half of the crew served weapons personnel of each unit. The medical platoon must be prepared to support the force which is withdrawing as well as the DLIC. The problem of available time to acquire, treat, and evacuate patients from the line of contact may be critical. A proportionate medical capability remaining with the DLIC may require implementation of some unusual methods of support. Among the potential plans to support the DLIC are the following:

- Maximum use of Army air ambulances to evacuate patients from company areas directly to the Role 2 BSMC and/or supporting EAB medical asset if the weather, availability of aircraft, and tactical situation permits.
- Medical platoons remain in original locations. The seriously wounded are sorted by combat medics and evacuated to the treatment team while the slightly wounded are evacuated directly to the nearest divisional medical company by nonmedical transportation.
- The seriously wounded sorted by combat medics are evacuated to the medical platoon, but the slightly wounded are evacuated to collecting points established in forward areas (forward of the medical platoon location) by either medical or nonmedical transportation.
- All patients are evacuated to the collecting points, and division level ambulances pick up patients at the collecting points. Use of collecting points forward of the normal aid station site reduces the time-distance involved in moving a patient to a point where they can receive EMT.
- In each of these plans, it is advisable to issue litters to the maneuver elements to enable them to assist in collecting and evacuating some of their own casualties.

3-94. The balance of the maneuver battalion medical platoon is placed predominantly rearward. Medical support organization during march operations is modified accordingly. The bulk of the medical platoon resources and as much ambulance capability as can be spared is sent with advance elements to the next designated battalion assembly area where a treatment team is established. A small treatment and ambulance element, reinforced as required by BSMC ambulances, marches at the rear of the main

body, picking up patients at collecting points along the route predesignated by the brigade medical plan, and accepting patients from the security force as indicated above. Patients are transported with the rear element to the new medical platoon location unless emergency evacuation is required. The security restrictions on movement and reduced visibility of darkness may dictate emergency evacuation by ground vehicles. A full patient load is moved rearward with the emergency sortie whenever possible because the ambulance probably will not be able to return to the tail of the column. Temporary halts at battalion assembly points permit the rear element to evacuate its patients in accordance with the division medical plan. The few air evacuation movements permitted are used primarily to transport critical patients directly to corps hospitals.

3-95. The daylight withdrawal, employed as a last resort, normally requires movement of combat columns through a single, large covering force, preferably tank heavy. Unit-level AHS support of the covering force is provided essentially as discussed for its security mission, except that extensive air evacuation of patients cannot be anticipated due to security restrictions and the lack of air cover. The Role 1 BAS of the covering force's maneuver battalion is not normally reinforced by Role 2 BSMC medical assets because these assets are usually overwhelmed by dual area missions detailed below. TACSOP usually prescribe priorities for use of general purpose transportation for patient movement. These SOPs provide the covering force commander with basic guidance for alternate plans to move casualties when the force must displace rearward without sufficient ambulance assets.

3-96. The supporting Role 2 BSMC must ensure they maintain sufficient treatment capability at their current locations to support the casualties received from the DLIC while they take prompt action to move a portion of the BSMC to a new location. It is imperative that a treatment team be operational in a new rear location prior to the closure and movement of the treatment team located in the forward location. In addition to AHS support provided the DLIC, there is a requirement to support the main force which moves to the rear at an early stage in this operation. When such a move is made, march column medical support can be provided by establishing march CCPs along the route where patients can be left for pickup by medical platoon personnel marching in the column or at the rear of the column. If this move of the main force is by infiltration, patients should be carried by their parent units to the rear assembly area or to Role 2 or 3 in the support area (the former is more likely), and medical assets should be positioned in the assembly area to receive such patients.

3-97. Echelons above brigade medical assets in support of the brigade are established at minimal size and well to the rear of the first line of alternate positions. If combat and environmental conditions indicate a light patient load and the road network permits rapid ambulance movement laterally as well as along the axis of withdrawal, two or even one area treatment teams may be utilized to provide general AHS support to all withdrawing brigades. Area treatment team activity consists principally of prompt sorting of patients to determine who must be evacuated immediately to the supporting Role 3 hospital center or field hospital and to provide required emergency and resuscitative treatment to prepare the more seriously injured or ill patients for early evacuation. Definitive treatment is provided only to those patients who are reasonably self-sufficient and who can travel with little jeopardy to their condition on general purpose transportation. The

BSMC leapfrogs rearward, occupying successive planned positions placed deeply along the withdrawal route to minimize the requirement for multiple displacements by any one platoon. Leapfrog tactics avoid unnecessary interference with combat operations while providing continuous support. Brigade support medical company and/or EAB ambulances are employed no farther forward than the principal element of each supported maneuver battalion medical platoon with the division's main force, except that a light reinforcing detachment may be required to support the covering force in a daylight withdrawal. If the withdrawal is rapid, ambulance elements may leapfrog rearward, prepositioning a small pool of vehicles to support each succeeding aid station location, rather than shuttling ambulances between medical platoons and companies, as is customary. Preparation for the withdrawal operation includes a push distribution of medical consumable supplies and nonexpendable exchange items to each medical unit or element. The special allotment is required to overcome effects of abnormal isolation of treatment elements and intermittent operation of the patient evacuation system.

3-98. If a withdrawal is made under enemy pressure, the AHS support considerations are quite different. Since time available in this instance is even more critical than the voluntary move, the Role 1 BAS and Role 2 BSMC cannot remain in the forward areas. They usually withdraw as a unit to new rear locations and casualties occurring during the withdrawal are transported to the support areas by their parent units, usually on nonmedical transportation. Again, it is highly desirable that litters be issued to the maneuver element to enable them to evacuate their own casualties without increased discomfort to the patient.

ARMY HEALTH SYSTEM SUPPORT OF THE RETIREMENT

3-99. A *retirement* is an operation in which a force out of contact moves away from the enemy (ADP 3-90).

3-100. Because the battalion breaks contact with the enemy and marches in multiple columns directly to the rear, the AHS support requirement is similar to a movement to contact. The battalion's patient workload is usually light. Augmentation of ambulance assets with organic medical elements of the rear guard may be required but its treatment capacity should be adequate for emergency procedures needed to prepare the patient for evacuation to the main body. Treatment and evacuation support and marching at the rear of the main body is provided essentially as discussed for medical support of the withdrawal. The prospect of an extended retirement march requires additional ambulance support with these rear elements. The Role 2 BSMC displaces sufficiently far enough to the rear before the main forces move to preclude having to further displace during the operation. Echelons above brigade ambulances accelerate evacuation of patients from medical companies prior to the actual displacement. The number of medical companies to be established at destination depends principally on the type of defense to be employed and the adequacy of the road network.

SECTION III – ARMY HEALTH SYSTEM SUPPORT IN STABILITY AND DEFENSE SUPPORT OF CIVIL AUTHORITIES OPERATIONS

3-101. Stability is an overarching term encompassing various military missions, tasks, and activities conducted outside the United States in coordination with other instruments of national power to maintain or reestablish a safe and secure environment and to provide essential governmental services, emergency infrastructure reconstruction, and humanitarian relief.

3-102. Similar to stability operations the United States Army conducts defense support of civil authorities' tasks only in the homeland in response to requests for assistance from civil authorities for domestic emergencies.

ARMY HEALTH SYSTEM SUPPORT TO STABILITY OPERATIONS

3-103. Army Medicine has historically conducted foreign humanitarian assistance operations when deployed in overseas areas. In some scenarios, medical forces may be deployed prior to the deployment of maneuver forces due to the humanitarian nature of their activities and medical personnel are more acceptable to a host nation than the deployment of operating forces.

3-104. Although the medical commander can provide the combatant commander (also referred to as CCDR) assistance in planning for the primary stability tasks to restore essential services and support to economic and infrastructure development, the assistant chief of staff, civil affairs is the responsible staff agency for developing and planning civil affairs operations. This ensures that all stability activities conducted are in consonance with the combatant commander's theater engagement strategy.

3-105. Table 3-3 depicts stability tasks, purposes, and key medical considerations for the preparation for the conduct of these tasks. For more information on stability tasks see DOD Directive (DODD) 3000.05, ADP 3-0 and ADP 3-07, and ATP 4-02.42.

Table 3-3. Stability tasks, purposes, and key medical considerations

<i>Stability tasks</i>	<i>Purposes</i>	<i>Key medical considerations</i>
<ul style="list-style-type: none"> Establish civil security (including security force assistance). Establish civil control. Restore essential services. 	<ul style="list-style-type: none"> Provide a secure environment. Secure land areas. Meet the critical needs of the populace. 	<ul style="list-style-type: none"> Regionally focused medical command and control to promote unity of purpose of all engaged medical assets.

Table 3-3. Stability tasks, purposes, and key medical considerations (continued)

<i>Stability tasks</i>	<i>Purposes</i>	<i>Key medical considerations</i>
<ul style="list-style-type: none"> • Support to governance. <ul style="list-style-type: none"> • Support to economic and infrastructure development. • Conduct security cooperation. 	<ul style="list-style-type: none"> • Gain support for host-nation government. • Shape the environment for interagency and host-nation success. 	<ul style="list-style-type: none"> • Medical information management to document health threat exposures and medical encounters, to report health surveillance data and information on the health of the command, and to accomplish medical regulating and patient tracking operations. • Traditional medical support to a deployed force engaged in performing these tasks. • Medical expertise and consultation to enhance building partnership capacity in public, private, and military health sectors of the host nation. • Development of regional theater security cooperation plans aimed at mitigating or resolving the underlying causes of health issues prevalent within the region.

ARMY HEALTH SYSTEM SUPPORT TO DEFENSE SUPPORT OF CIVIL AUTHORITIES OPERATIONS

3-106. Defense support of civil authorities is support provided by United States Federal military forces, DOD civilians, DOD contract personnel, DOD component assets, and Army National Guard forces (when the Secretary of Defense, in coordination with the Governors of the affected States, elects and requests to use those forces in Title 32, United States Code, status). This support is in response to requests for assistance from civil authorities for domestic emergencies, law enforcement support, and other domestic activities or from qualifying entities for special events. Defense support of civil authorities is a task that takes place only in the homeland, although some of its tasks are similar to stability tasks. Table 3-4 on page 3-30 identifies defense support of civil authorities, tasks, purposes, and key medical considerations. For additional information on these types of tasks refer to ADP 3-28.

Table 3-4. Defense support of civil authorities tasks, purposes, and key medical considerations

<i>Defense support of civil authorities tasks</i>	<i>Purposes</i>	<i>Key medical considerations</i>
<ul style="list-style-type: none"> • Provide support for domestic disasters. • Provide support for domestic chemical, biological, radiological, and nuclear incidents. • Provide support for domestic civilian law enforcement agencies. • Provide other designated support. 	<ul style="list-style-type: none"> • Save lives. • Restore essential services. • Maintain or restore law and order. • Protect infrastructure and property. • Maintain or restore local government. • Shape the environment for interagency success. 	<ul style="list-style-type: none"> • Coordinate, integrate, and synchronize Army Health System resources into the interagency efforts. Further, provide medical expertise to identify and analyze critical needs emerging within the operational area. • Medical information management to facilitate medical regulating of victims to facilities outside of the disaster/incident site and to document medical treatment. • Assist affected medical infrastructure in saving lives, reducing long-term disability, and alleviating human suffering. • Assist the local government in conducting rescue operations and providing medical evacuation of victims to facilities capable of providing the required care. • Preventive measures to respond to and resolve emerging health threats caused by the disaster/incident.

SECTION IV – ARMY HEALTH SYSTEM SUPPORT TO NIGHT OPERATIONS

3-107. Night operations call for disciplined and self-reliant troops. The mental strain involved in night combat is severe; it is easier to endure in periods of activity than during long spells of inactivity. This is why at night, even more so than by day, the unit that takes the initiative has the advantage. However, since orientation and coordination will become increasingly difficult, this initial advantage diminishes as the attack progresses. Darkness is helpful in achieving surprise, and the attacker will derive additional advantages from the defenders inability to fire effectively. To maintain control and intraunit contact and communication is difficult during the hours of darkness, and unit commanders must prepare every detail of the operation plan with meticulous care. Any contingency, however farfetched, must be taken into consideration. Success of a night attack also depends on the resourcefulness and initiative of subordinate leaders and their ability to make independent decisions in line with the overall plan. Furthermore, since frequent and accurate reporting is of great importance, the existence of a smoothly operating communication system is essential. Every possible method of deception, camouflage, and concealment must be employed in night operations.

3-108. Success of night operations depends primarily on careful planning, detailed preparation, simplicity of the OPORD and tactical procedure, achievement of surprise, and the leaders' calmness and circumspection. Every officer who is to participate in a night operation must be initiated into the plan. The more thorough the daytime preparations the more certain the success. Tactical maneuvers and the mechanical handling and servicing of weapons and equipment are slowed down and complicated by darkness. Proper condition and meticulous care of weapons and equipment are essential.

CONDUCTING NIGHT OPERATIONS

3-109. The medical platoon leader must anticipate that the battalion will do a substantial amount of work at night or in limited visibility. They must ensure that the platoon TACSOP is available and used throughout the battalion for providing treatment and MEDEVAC at night. Real-life trauma care at night will be enhanced by the ability to use white light (visible light) at the earliest opportunity. Therefore, medical units/elements must establish standard procedures to use white light without compromising the tactical environment. This means routinely training to erect shelters as soon as possible during hours of darkness. Personnel must understand that some shelters block visible light, but that the same shelters glow when viewed through night vision devices. In some extremely mobile situations, ambulance/vehicles could be used to enclose patients and health care providers allowing treatment to proceed under white light conditions.

3-110. Medical leaders must understand night operation technology and their capabilities for conducting night operations. Medical platoon personnel should know how to use both far infrared devices (and how their capabilities can enhance AHS support operations at night) such as the combat identification panel. The medical platoon leadership needs to know the status and amount of equipment on-hand and to identify equipment needed. They must plan the SOPs and METT-TC specific techniques necessary to perform the AHS support mission. For these types of operations, the platoon leader should be advised to consider—

- Appropriating civilian buildings to reduce light and thermal signatures.
- Maintaining light discipline within occupied shelter or structure.
- Using nonvisible spectrum light in conjunction with night vision devices.
- Reducing noise signature to a minimum.
- Using chemical lights may be applicable. However, overuse of chemical lights degrades light discipline and security. Chemical lights are visible from a distance of a kilometer (.62 mile) or more.

3-111. Possible techniques for medical units/elements include:

- Using chemical lights to light command post areas eliminating generator noise and thermal signature.
- Allowing placement of color chemical lights on vehicles.
- Illuminating areas of vehicle engine compartment for night repairs using chemical lights.
- Regulating the amount and direction of light utilizing chemical light holders.

ARMY HEALTH SYSTEM SUPPORT CONSIDERATIONS

3-112. Light discipline requirements affect AHS support operations as much as they do supply and maintenance operations. Medical units/elements will use additional fuel to run a vehicle-mounted night site. Treatment operations require lightproof shelters. Patient acquisition is more difficult. Units should employ some sort of casualty-marking system such as luminous tape.

3-113. Limited visibility slows MEDEVAC. This requires additional ground ambulances to compensate. In the offense, ambulances move forward with BAS. However, personnel have to accomplish this movement carefully to avoid signaling the threat. Personnel use predesignated AXPs. Medical evacuation by air ambulance is difficult and requires precise grid coordinates as well as prearranged signals and frequencies. As in daylight, AHS support operations conducted at night require active participation of all involved units. Standard operating procedures must include near and far recognition, signaling, predetermined marking of the CCP, routes, and the BAS. Maximum use of modern navigation tools, such as global positioning satellite, infrared, and night vision devices, will enhance the ability of medical units/personnel to carry out AHS support of night missions. Night operating procedures must be routine and practiced as a part of operating procedures. This is especially true for medical units/personnel since they have a 24-hour responsibility under all conditions, not just combat operations.

INFRARED DEVICES

3-114. A far infrared device is a “quick fix” device for friendly identification. Combat identification panels do not replace current acquisition, identification, or engagement procedures. They provide a device visible through thermal sights to increase situational understanding and provide a safety net at the normal engagement range. These devices can be used to further identify medical vehicle and units.

3-115. Near infrared devices that aid in C2 may be used for signaling and marking devices. The infrared beam is an effective means to increase situational understanding and combat effectiveness and improve identification. When used for marking obstacles, seized terrain, and breached sites, these devices reduce the fratricide risk. Additionally, these lights are signaling devices (that is, configuration of certain patterns to indicate unit identification, turn on/off to signal accomplishment of a task, cross a phase line, and signal from one ground position to another specific position, or from ground to air). They are also useful in specialized units such as pathfinders for marking pickup, drop, or LZs. These are excellent devices for near recognition signaling to guide incoming evacuation vehicles.

NIGHT VISION DEVICES

3-116. Each vehicle in the medical platoon will most likely have two night vision devices. The wheeled vehicle driver will use either the AN/PVS-7B (discussed below)

or the driver's vision enhancer (DVE). The DVE is a thermal imaging system capable of operating in degraded visibility conditions such as fog, dust, smoke, and darkness. In conditions of reduced visibility, the DVE allows a vehicle to maintain speeds up to 55 to 60 percent of those attained during normal daylight operations. Unlike traditional night vision devices that magnify ambient light, the DVE generates a picture based on minute variances in temperature in the surrounding environment. It gives the operator visibility to the horizon in total darkness and the ability to recognize a 22-inch object at a distance of 360 feet. It can elevate 35 degrees, depress 5 degrees, and rotate 170 degrees in either direction. The DVE consists of a sensor module, display control module, positioning module, wiring harness, and mounting equipment. A combat DVE and a tactical wheeled vehicle DVE will be available. The ambulance and treatment vehicle drivers will use a DVE if available or continue to wear night vision goggles. The night vision goggles (AN/PVS-7B, a hand-held, head-mounted, or helmet-mounted night vision system) enables walking, driving, weapons firing, short-range surveillance, map reading, treatment of patients, and vehicle maintenance in both moonlight and starlight. It has an infrared projector that provides illumination at close range and that can be used for signaling. There is a high light-level shutoff if the device is exposed to damaging levels of bright light. There is a compass that attaches to the device and allows for reading an azimuth through the goggles. This device has a weight of 1.5 pounds and operates on two AA batteries. The ambulance and treatment vehicle when fielded will have infrared headlights. These infrared headlights can be used for assisting drivers who wear night vision goggles and for signaling. As with all lights, extreme caution must be taken in tactical situations. The infrared headlights are typically very bright to personnel wearing night vision goggles.

TECHNIQUES FOR USING CHEMICAL LIGHTS FOR MARKING AND SIGNALING

3-117. For marking, chemical lights can be placed inside standard military short or long pickets to mark routes and positions. The concave side of the picket contains the chemical light and the convex side faces the most likely direction of enemy observation. This technique controls the direction of the light while assisting with such things as MEDEVAC routes, supported unit collection points, AXPs, or link-up point identification.

3-118. For signaling, tying a chemical light to a length of cord or string and twirling it overhead in a circle is an unmistakable signal. This only needs to be used until recognition (radio) is established. This technique makes use of widely available common supplies. It is especially useful for a unit guiding an incoming ground or air ambulance. Listed below are other ways this technique can be used:

- For marking casualty locations, for example, urban operations.
- For marking triage areas at the BAS to identify patient triage categories.

Note. Techniques are only limited to available equipment and imagination. The METT-TC should always take precedence.

SECTION V – ARMY HEALTH SYSTEM SUPPORT IN MOUNTAIN WARFARE AND COLD WEATHER OPERATIONS

3-119. Operations in mountainous regions or cold weather environments encounter dynamic challenges, which if not appropriately addressed, may result in failure or unnecessary loss. Individuals must understand the effects of the environment and have the training, stamina and willpower to take proper actions. The effectiveness of some equipment, is greatly reduced and maintenance of all equipment is of paramount importance. Specialized training and experience are essential. The mobility of all units is restricted and movement must be carefully planned and executed with the knowledge that distance can be as difficult to overcome as the enemy. All means of transportation must be used. In addition to concern for the effects of the environment on the medical platoon, extra care and precautions must be taken to the management of casualties. For more information see ATP 3-21.50 and ATP 3-90-97, Technical Bulletin (TB) Medical (MED) 505, TB MED 508, and TC 3-97.61. The medical platoon can utilize GTA 20-01-001 as a quick reference to cold weather operations.

ARMY HEALTH SYSTEM PLANNING FOR MOUNTAINOUS AND COLD WEATHER ENVIRONMENTS

3-120. The battalion, when operating in mountainous terrain, is often decentralized. In mountain warfare or similar types of operations, it may be necessary to operate as treatment teams. Reinforcement of personnel and equipment by the BSMC may then be required.

SPECIAL CHARACTERISTICS

3-121. In mountainous terrain there is usually adequate concealment and defilade to allow the medical platoon to establish the treatment teams close to the tactical operation. If the Role 1 BAS is consolidated, it should normally be located as close as possible to the fighting troops in the center of the battalion area. If the medical platoon is required to operate with split treatment teams each team should be given a specified area of responsibility, and located centrally and as far forward as possible in support of the troops for which that team is responsible. The term centrally located does not necessarily mean the geographical center of an area. Many factors such as expected patient loads, lines of drift, roads or paths for evacuation of casualties, terrain features having a direct influence on litter/manual carry must all be considered in determining a central location for a given area. The following advantages are obtained when proper consideration is given to the location of treatment teams:

- Relatively short or easy litter hauls.
- Medical units closer to the units they support.
- Closer contact with company commanders affords greater ease in following changes in the tactical plan.
- Increased rates of evacuation.
- Additional possibilities of adequate shelter.

3-122. Patients are triaged, given necessary emergency medical care and if designated as evacuees, provided with shelter and warmth until transportation becomes available.

3-123. When operating as separate treatment teams, the evacuation section should be augmented with additional litter teams. The additional personnel required to augment the medical platoon litter squads may be recruited from all available sources, including the use of indigenous personnel. The augmentation should be planned for and completed prior to its actual need.

COMBAT MEDICS

3-124. As in normal situations, combat medics will be attached to the companies by the medical platoon. The normal distribution for combat medics is three/four per rifle company. When critically short of medical platoon personnel, this allocation may not be possible. Reallocation of combat medics to meet existing conditions may help in solving this problem. When possible, combat medics should always be allocated to the same company (and platoon) to encourage close relationship between them and the men of the company. Emphasis should be placed on training the combat medics in hazards of cold and wind, the relationship of these factors to the problem of shock, conservation of body heat and improvised methods of providing warmth, to include the construction of small windbreaks and shelters and techniques of military mountaineering and mountain evacuation procedures.

LITTER RELAY POINTS

3-125. Litter relay points may have to be established. It would be wise in many situations if sufficient litter bearers are available, to establish a chain of litter relay points from the treatment teams back to a point where evacuation can be taken over by ambulance.

3-126. Each relay point should have one NCO and four litter bearers. However, when short of personnel, one NCO could be used to supervise more than one relay point. Each point is responsible for the evacuation of all patients received. When returning to their relay point, bearers bring back empty litters and other medical supplies which are required at forward areas. This will permit maximum use of available bearers because a given number of bearers operating in a chain of relay points can evacuate far more wounded than can be accomplished if each litter team attempts to evacuate the wounded from the FEBA to the rear, where ambulances can pick them up.

3-127. This system was frequently used in mountain fighting by both United States and British troops. It allows bearers to function continuously since each trip is relatively short, and the men become rested on their way back to their post. They also become familiar with the short section of mountain trail over which they travel. This makes it possible for them to operate over the trail at night, and provides safer transport of the wounded a much smoother ride.

3-128. This system is also of value because it curtails straggling which may be encountered when the same litter bearers are used from the FEBA all the way back to the ambulance loading point. It also maintains command and control over the litter teams by the unit responsible for that portion of evacuation.

3-129. The tactical problems of the medical units in mountain operations are similar to those encountered in flat terrain. Lack of good road networks will add to the difficulties encountered by medical units. The units should be located as close as possible to the supported unit, yet must be situated so as to permit evacuation by the units in support. Utilization of an ambulance squad forward of the BSMC may, at times, be impossible. Personnel normally employed in this link of the chain of evacuation may then be used as litter bearers or as supervisors of litter bearers furnished from other sources. Problems will arise, but by maximum utilization of personnel and equipment, the medical company can provide support within its area of operations.

MARCH COLLECTING POINTS

3-130. Combat medics accompany their respective companies on any march. By map or route reconnaissance, the medical platoon leader will establish collection points along the route of march. These collection points should be sheltered areas which have been marked in such a way as to be easily recognizable by litter bearers. Enlisted personnel of the medical platoon will be designated to take charge of these points. A minimum of two men per point should be used. Just prior to the start of the march, the men who have been assigned as collecting point attendants will join the head of the column. As the head of the column passes each collecting point, the personnel assigned to the point will drop out of the column and remain at their point until relieved. Specific responsibilities of the collecting point attendants should include administering necessary emergency care, providing adequate heat and shelter and required supervising patients evacuated to the collecting point. Patients evacuated by either the battalion, brigade, or the EAB ambulances may be evacuated to these collecting points.

SPECIAL EQUIPMENT NECESSARY IN MOUNTAIN OPERATIONS

3-131. Operations in mountains require medical platoon personnel to carry additional equipment. Items such as ropes, pitons, piton hammers, and snap links are all necessary for the evacuation of patients and establishment of aid stations. All unnecessary items of equipment including those for which substitutes or improvisations can be made should be left behind. Heavy tentage, bulky chests, extra splint sets, excess litters, and excess medical supplies should be stored. Such medical supplies, if stored should be readily available to the medical platoon leader for airdrop or other means of transportation upon his request. Medical items that are subject to freezing should not be exposed to the low temperatures experienced in mountainous areas. When freezable items must be hand carried, losses from freezing may be reduced by packing chemical heaters with the supplies or by having the Soldiers and medics carry the items beneath their parkas.

3-132. For forward medical units to maintain an adequate level of medical supplies, all personnel, vehicles, and aircraft going toward the forward areas should, whenever possible, carry small amounts of medical supplies and equipment such as blood substitutes, dressings, blankets, and litters. Equipment and supplies necessary for the establishing a treatment team can usually be man carried. Smaller supplies and equipment may be rolled in blankets and these rolls can be lashed to packboards or carried in an ahkio sled or partially folded litters. In addition to normal medical items,

it is advisable to carry a few shelter halves, hand axes, two or three nylon climbing ropes and some snap links for each aid station to be established.

SHELTER

3-133. Since the transportation of heavy tentage may be impractical, shelter for patients must be improvised to prevent undue exposure of the wounded. In the summer or in warm climates, improvisation may not be necessary, but since there is a close relationship between extreme cold and shock, medical platoon personnel should always be conscious of the necessity of providing adequate shelter for patients. Satisfactory shelter may be found in caves, under overhanging cliffs, behind clumps of thick bushes, near the base of trees, or in ruins, or shelter may be built using a few saplings, evergreen boughs, some shelter halves or similar items. The time factor will often have strong influence on the type of shelter used. When patients are to be kept overnight, a better weatherproofed shelter should be constructed.

EVACUATION

3-134. There are special considerations in evacuating patients to the rear. The evacuation of wounded in mountainous operations presents varied problems. In addition to the task of carrying a patient to the nearest treatment team, there is the difficulty of movement over rough terrain.

3-135. The proportion of litter cases to ambulatory cases is increased in mountainous terrain since even a slightly wounded individual may find it difficult to negotiate the rugged terrain. Because of this added exertion and increased pain, it may be necessary to transport a patient by litter who would normally be able to return to the aid station by himself.

3-136. In cold weather and in high mountains speed of evacuation is vital as there is a marked increase in the possibility of shock among patients when injuries occur in extreme cold. High mountains are difficult to evacuate from due to lack of road networks and altitude.

3-137. Special consideration must be given to the conservation of manpower. Use of litter teams must be kept as short as the tactical situation will permit. A litter team is not capable of carrying a patient over mountainous terrain for the same distance as over relatively flat terrain. In order to decrease the distance of litter haul, all forward medical units should be as close as possible to the troops supported.

3-138. It is important to be able to predict the number of patients that can be evacuated by available personnel. It has been demonstrated that when the average terrain grade exceeds 20 to 25 degrees the four-man litter team is no longer efficient and should be replaced by a six-man team. The average mountain litter team should be capable of climbing 120 to 150 vertical meters of average mountain terrain and returning with a patient in approximately one hour.

3-139. Another factor to be considered is the problem of evacuation at night. Wounded should be located and evacuated during the day as much as possible as many would not survive the rigors of the night on a mountain during cold weather. Night evacuation

over rough terrain is generally impracticable and the results are rarely commensurate with the effort. It should be attempted only when the route has been reconnoitered, and marked with tracing tape and a rope handline installed. If routes are exposed to enemy observation and fire by day, patients should be removed from the area at hours of darkness. When required, patients should be moved only as far as necessary during the night. At the first point affording shelter from enemy observation and fire, a temporary holding station should be established capable of providing shelter, warmth, food, and supportive care. Patients should be brought from the forward areas to this point, held until daylight, and then evacuated farther to the rear.

3-140. The difficulties MEDEVAC might encounter in mountain operations emphasize the advantages of air evacuation of patients. It cannot be assumed that helicopters will be readily available for evacuation of patients from forward areas. Helicopters provide faster, more economical transportation for patients than other methods which might be used. The reduction of time lapse between injury and treatment has such a direct effect on the time required for recovery and the final results of the treatment that the use of the most rapid, most comfortable, and the safest means of evacuation is mandatory. The fact that aircraft may not be available because of weather, enemy capabilities, terrain features, maintenance problems, or other situations prevents the medical planner from relying entirely on aircraft for the evacuation of patients in rough mountainous terrain.

ROUTES

3-141. The first and most important task before evacuation can be executed is a thorough reconnaissance of the terrain features and the road network in the area. To this information is added a consideration of the prevailing climatic conditions, the facilities and personnel available, and the tactical mission. Only after all these factors are assembled and evaluated can a sound MEDEVAC plan be formulated. The following factors peculiar to mountain operations should be given consideration prior to making the final selection of evacuation routes:

- Snow and ice are firmest during the early morning hours.
- Glacial or snow fed streams are shallowest during the early morning.
- Channels of mountain streams afford poor routes of evacuation because of rough, slippery rocks and the force of the moving water.
- Talus slopes should be avoided because they are difficult to traverse. Loose and slippery rocks on such slopes will often cause litter bearers to fall and drop the patient with possible injury to all.
- When possible, routes should be chosen just below the crest of a ridge since these trails are usually easiest to follow and the ground affords the best footing in such areas.

MEDICAL SUPPLIES (CLASS VIII INCLUDING MEDICAL REPAIR PARTS)

3-142. High consumption rates for medical supplies should be anticipated. Solid medications and freeze-dried material instead of liquids can be used when building the list of authorized medical stocks to minimize freezing, storing, and handling problems.

Refrigerated and heated storage areas, such as warming tents, vehicles, and containers, are required for storing liquid medications and packed red blood cells or fresh whole blood that has been collected and processed on an emergency basis in theater (see ATP 4-02.1). Perishable materials must be packaged and marked for special handling. Procedures must be established and followed for special handling requirements for Class VIII material from embarkation to its final destination. There will also be an increased requirement for lip balm, sunscreen, cough syrup, and decongestants. More information regarding medical supplies is presented in this chapter under medical support considerations.

MEDICAL SUPPORT CONSIDERATIONS

3-143. Numerous cold and altitude illnesses and injuries threaten personnel operating in a mountainous/cold weather environment. In a cold, mountainous environment, personal hygiene is difficult to maintain due to limited water. The potential for the spread of infectious diseases increases by confined living spaces shared by multiple individuals. Field hygiene and sanitation is important. Personnel use sunscreen and sunglasses to prevent severe sunburns and damage to the eyes from the sun's ultraviolet rays, which are possible at high altitude or in snow-covered environments.

3-144. For small-unit operations with widely-dispersed forces, all troops must be well-trained in CLS and CASEVAC procedures, including the following:

- Self-aid/buddy aid, advanced first aid, and field sanitation.
- The use and capabilities of the CASEVAC bag and pole-less litter, including CLS and higher levels of first responder care.
- The ability to transmit a 9-line MEDEVAC request and setup of a HLZ.

3-145. Each squad (preferably each fire team) has one trained CLS to augment the platoon's combat medic. Also, MEDEVAC crew chiefs should be CLS trained to assist, if time and the mission allow, during flight operations. Given the distances involved, en route patient care is vital.

3-146. Medical platoon personnel have some unique training requirements for mountain operations. Hoist operations are a planning consideration for medical units operating in mountainous areas. These personnel are trained and familiar with high, steep-angle rescue, air CASEVAC, and the equipment used in hoist operations, preferably using actual air platforms in rugged terrain. Mountain operations require evacuation teams, preferably Level 2 mountaineers, who have the capability to reach, stabilize, and evacuate casualties in the steepest terrain. All personnel are trained to conduct less technical, steep-slope evacuations.

CASUALTY EVACUATION AND COLLECTION

3-147. Casualty evacuation is the movement of casualties aboard nonmedical vehicles or aircraft. Casualties transported in this manner may not receive proper en route medical care or be transported to the appropriate role of care to address the patient's medical condition. When possible, nonmedical vehicles have a combat medic or CLS on board. On nonmedical aircraft, sufficient space may not be available

to permit a caregiver to accompany the casualties, and the type of en route monitoring or medical care and first aid provided may also be limited. Casualty evacuation is used in extreme emergencies or when the MEDEVAC system is overwhelmed.

3-148. Mountain operations present numerous challenges for casualty collection and evacuation. Leaders consider the following when planning mountain operations:

- Difficulty associated with accessing casualties in rugged terrain.
- The increased need for technical mountaineering skills for CASEVAC.
- Proximity of expert medical help.
- Longer periods of wait time for CASEVAC.
- Prior to evacuation, injured and immobilized patients are at the greatest risk of cold injury, and they must be well-insulated during transport.
- Evacuating the wounded from mountainous areas normally requires a larger number of medical platoon personnel and litter bearers than on flat terrain. Soviet experience in the mountains of Afghanistan proved that three to 15 men might be involved in carrying one patient.
- Tough, physical casualty handling should be conducted in every training event.

3-149. Each unit should have a detailed CASEVAC plan that is repeatedly rehearsed. Each support area must have ground evacuation assets and a dedicated security element. The security element is on call and familiar with primary and alternate routes to higher roles of care (Roles 2 and 3). Commanders consider what levels of risk they are prepared to accept to air evacuate patients using nonmedical aircraft.

MEDICAL EVACUATION

3-150. A MEDEVAC is performed by dedicated, standardized MEDEVAC platforms (ground and air ambulance), with medical professionals who provide the timely, efficient movement, and en route care of the wounded, injured, or ill persons from the battlefield and other locations to the supporting Role 2 or Role 3. Air MEDEVAC of seriously wounded personnel is the preferred method in mountain operations. Hoist operations are inherently dangerous and result in fatalities if preventive measures are not considered. Personnel need training prior to deployment on MEDEVAC procedures and the equipment used in hoist operations. Positioning aviation assets forward on the battlefield is critical to supporting such operations, however, during periods of decreased visibility and high winds, these assets cannot fly and land in extreme mountainous terrain.

ACCLIMATIZATION

3-151. Regardless of an individual's standard of physical fitness, all personnel acclimate in order to be effective and to prevent associated altitude illness. Acclimatization achieves maximum physical and mental performance and minimizes the threat of altitude-related illness. Mountain warfare training is not a substitute for the acclimatization process but it does provide personnel with an appreciation for the challenges of surviving and fighting in a mountainous environment.

3-152. Acclimatization is required before undertaking extensive military operations. Even the most physically fit troops experience physiological and psychological degradation when thrust into high elevations. Time must be allocated for acclimatization, conditioning, and training. There is no shortcut for the acclimatization process and any attempt to trim or bypass the process will result in injuries. Commanders should see FM 7-22, ATP 7-22.1, and ATP 7-22.2 to build physical fitness plans that will help prepare personnel for operations at altitude.

3-153. For most troops between elevations of 2,438 meters (8,000 feet) and 5,486 meters (18,000 feet), 70 to 80 percent of the respiratory component of acclimatization occurs in seven to 10 days, and 80 to 90 percent of overall acclimatization is generally accomplished within two weeks to one month. Maximum acclimatization may take months to years. Acclimatization cannot be accelerated as some troops acclimate more rapidly than others, and a few may not acclimate at all. There is no reliable way to identify those who cannot acclimate except by their experience during previous altitude exposures. When brought to lower altitudes, all personnel will lose their acclimatization in a matter of days.

3-154. There are two methods for acclimating troops in high mountains: the staged ascent and graded ascent. In a staged ascent, troops ascend to an altitude of 2,438 to 3,962 meters (8,000 to 13,000 feet) and remain there for four days or more to acclimate before ascending higher. When possible, troops should make several stops during the ascent to allow for increased acclimatization. A graded ascent limits the daily altitude gain to allow partial acclimatization. The altitude at which troops sleep is critical to acclimatization—work high, sleep low is a rule of thumb (for example, sleeping 1,000 feet lower than the working elevation. Once they have ascended to 2,438 meters (8,000 feet), troops should gain no more than 300 meters (984 feet) of sleeping altitude each day. This process reduces high-altitude illnesses. A combination of staged ascent and graded ascent is the safest and most effective method to prevent high-altitude illnesses.

ARMY HEALTH SYSTEM COLD WEATHER PLANNING FACTORS

3-155. In northern latitudes, conducting military operations is circumscribed by considerations foreign to more temperate regions. The long hours of daylight and the heat and dust of summer, the long nights and the bitter cold and storms of winter, the mud and morass of the transition periods of spring and autumn, the disrupting effects of natural phenomena, the scarcity of roads and railroads, the vast distances and isolation and occasionally the lack of maps combine to adversely but not totally restrict mobility, firepower, and communications. In spite of adverse conditions, operations are feasible through employment of aggressive leadership, a high state of training, and adequate logistical support. Discussed below are special factors peculiar to north environments that may will influence planning.

LOW POPULATION DENSITY

3-156. Settlements, supplies, quartering facilities and lines of communication will be limited. Their control or destruction becomes of major importance.

ROADS AND RAILROADS

3-157. Roads and railroads may be limited and those that do exist are usually vulnerable to enemy action. In addition, climatic conditions may greatly affect their use.

LAKES AND WATERWAYS

3-158. Lakes and waterways are prevalent and may either aid or hinder operations depending upon climatic conditions. With sufficient ice thickness, they are easily crossed and may be used as natural routes of communications or airstrips. In some instances, drifted and hard-packed snow makes landing on ice difficult, requiring further preparation of an airstrip. Many streams are glacier fed, and in the summer, they carry great volumes of water and can become either major barriers or lines of communications.

NAVIGATION

3-159. Difficulty of land navigation is increased by lack of landmarks, large forested areas, periods of reduced visibility, difficulty of cross country movement and large magnetic declinations in areas adjacent to the magnetic pole.

WEATHER

3-160. Weather is an important factor to be considered while assessing the situation and may dictate a particular COA. As an example, the attacker or defender in a snowstorm with the wind at their back has a marked advantage.

WHITEOUT

3-161. At times, overcast sky and snow-covered terrain create a condition of visibility which makes recognition of irregularities in terrain very difficult.

FORESTED AREA

3-162. Forested areas offer concealment and present excellent opportunities for ambushes and hit-and-run tactics. They provide comparatively good protection against wind and snowstorms but present a serious obstacle to cross-country mobility. In the summer, forests burn easily, and fires may become a major problem. Units in forested areas are highly vulnerable to the blast effect from nuclear weapons.

SNOW COVER

3-163. Snow enhances the movements of troops suitably equipped and trained but reduces the mobility of troops lacking the proper equipment and training.

ICE COVER

3-164. The freezing rivers, lakes, and swamps may aid movement operations.

EXTREME COLD

3-165. The effects of cold must be considered, however the proper use of clothing and equipment will largely overcome any difficulties.

SUDDEN CHANGES IN WEATHER

3-166. These changes include extreme temperature changes, snowstorms, strong winds, and dense fog. Changes may be sudden and must be planned for. Every advantage must be taken of favorable conditions of even short duration.

DAYLIGHT AND DARKNESS

3-167. The increased hours of nighttime in winter must not be considered a bar to operations. For example, movement, camp building and breaking, and scouting and patrolling must be considered normal night activities. The proper utilization of the available daylight hours assumes major importance in planning.

ICE FOG

3-168. The phenomenon of ice particle fogs is a very common occurrence around inhabited areas during cold winter weather. They are found when temperatures drop below 20 degrees Fahrenheit. Their origin, in marked contrast to that of ordinary super cooled fogs, lies in the copious local production of water vapor by human activities, coupled with an inability of stagnant air at such low temperatures to hold the water vapor. Such sources of water vapor may include the exhaust from vehicles and aircraft, the vents of steam from permanent type heating systems, the air ventilated from humid rooms and the stove pipe effluent from space heaters. In the field, such a fog may appear over a body of troops, a herd of animals, bivouac areas, motor parks, airfields, convoys and gun positions when firing. Ice fog obscures the driver's vision along the line of fire and may disclose the locations of weapons, vehicles, and/or troops.

SEASONAL TRANSITION

3-169. The periods of seasonal transition must be carefully considered. Climatic changes become more abrupt and the appearance of terrain features changes rapidly. A frozen river may present little problem one day but be a major obstacle the next day.

ATMOSPHERIC DISTURBANCES

3-170. Extended operating distances and atmospheric disturbances make military communications difficult.

DELAYED PERSONNEL RESPONSES

3-171. The extreme environmental problems encountered by personnel require that delay and time lag be considered in all planning.

MOBILITY

3-172. Ground mobility is affected by inadequate transportation nets. During winter, low temperatures, snow and ice, and the difficulties of constructing roads and trails hinder movement. During the breakup season, ice is weakened on lakes and streams, and existing roads become almost impassable. Extensive overland movement is difficult during the summer because the underlying permafrost prevents effective drainage and extensive swampy areas result. Movement by Army aircraft equipped with conventional

landing gear, skis, and amphibious landing gear or flotation kits offers an effective means of mobility (and patient evacuation) in the undeveloped regions of the north.

EVACUATION

3-173. Because of the hostility of the northern environment, a task force operating in northern latitudes should establish a relatively short patient holding period. Adverse environmental conditions under which the medical platoon personnel function makes it exceedingly difficult to provide extensive definitive care over an extended period of time. The general nature of the cold weather terrain makes surface evacuation of patients difficult in winter and virtually impossible in summer. The frozen tundra and permafrost form an exceedingly rough roadbed which makes patient evacuation slow. In summer, the tundra becomes marshy, streams vary from mere trickles to large torrents and operation of ambulances off the existing road network is often impossible. The lack of adequate road networks and the military necessity of moving supplies over the same route greatly restrict patient evacuation.

3-174. Ambulances are required for movement of patients from the Role 1 through Role 3 to airfields and for patient evacuation when weather conditions do not permit air evacuation. The most practical means of patient evacuation is by helicopter. Ideally, the battalion should be supported by helicopters for primary evacuation. For evacuation outside of the battalion area, air evacuation out of the theater of operations is again the primary means. Aircraft resupplying the task force can be used to carry patients on the return trip.

COLD WEATHER ENVIRONMENT MEDICAL CONSIDERATIONS

3-175. To enhance AHS support in extremely cold weather, the following considerations apply:

- Prompt acquisition and evacuation of patients to heated treatment stations.
- Augmentation of collecting elements of both unit and EAB division-level medical units.
- Use of enclosed and adequately heated transportation for evacuation.
- Provision of heated shelters at frequent intervals along the route of evacuation.
- Readily available air transportation for patient evacuation.
- Special snow traversing type vehicles for medical surface evacuation of casualties.
- Heated storage of medical supplies.

TIMELY MEDICAL SUPPORT

3-176. In the deep snows, storms, and bitter cold of winter, prompt evacuation and treatment of patients is even more essential than in temperate zones. It is extremely difficult to find and evacuate patients, and early medical aid can be rendered only if trained personnel are immediately available. Procedures should be established for

rendering medical aid on patrols, at strong points, and in heated first aid stations (tents) near the forward areas. If medical platoon personnel are not readily available, arrangement must be made for prompt evacuation of patients by other personnel. In the muddy seasons, it is necessary to place facilities for emergency treatment well forward in the combat area to prevent unnecessary losses due to time delay in evacuation. In summer, the evacuation and care of wounded is hampered by poor road conditions, dust, and insects. When feasible, the most successful method of evacuating wounded from the combat area is by air.

FIRST AID TRAINING

3-177. Extensive training in self-aid/buddy aid for all personnel in combat units is essential.

BACKUP MEDICAL SUPPORT

3-178. A Role 1 BAS should be with the direct support elements to provide backup medical support to the Role 1 or Role 2. Consideration should be given to equipping this element with radios which will be on the same net as the Role 1 and/or Role 2 and provide equivalent MEDEVAC vehicles to furnish similar mobility as provided by the BAS.

3-179. Backup medical support should be provided by a hospital unit from the corps support EAB units. The size of a task force will dictate the bed requirements and the type of unit best suited for the assignment. The Role 3 should utilize liners unless better housing is available. Flooring is considered mandatory. Water trailers should be kept in heated areas or provided with heater units to prevent freezing.

DECENTRALIZATION

3-180. Leadership is extremely demanding and important in hostile environments. Emphasis is on small-unit operations. Command is decentralized to insure maximum flexibility for leaders at all levels. Resourcefulness and initiative are requisites for unit commanders. Forceful action is the key to success in the north. Medical leadership at all roles of care must plan and prepare their operations in great detail, actively supervise, keep themselves and their subordinates informed and maintain close coordination with adjacent and supporting units.

SECTION VI – ARMY HEALTH SYSTEM SUPPORT TO JUNGLE OPERATIONS

3-181. The jungle environment includes densely forested areas, grasslands, cultivated areas, and swamps. Jungles are classified as primary or secondary jungles based on the terrain and vegetation.

3-182. The climate in jungles varies with location. Close to the equator, all seasons are nearly alike, with rains throughout the year; farther from the equator, especially in India and Southeast Asia, jungles have distinct wet (monsoon) and dry seasons. Both zones have high temperatures (averaging 78 to 95+ degrees Fahrenheit), heavy rainfall

(as much as 1,000 centimeters [400+ inches] annually), and high humidity (90 percent) throughout the year.

3-183. Severe weather also has an impact on tactical operations in the jungle. The specific effects of weather on operations are discussed throughout this manual. For more information on jungle operations see ATP 3-90.98.

MEDICAL CONSIDERATIONS

3-184. The evacuation of casualties in jungle operations presents a difficult problem. The task of carrying a patient to the treatment team may require the traversing of rough terrain. Forward evacuation and treatment of patients involves special considerations. Ambulances may not prove practical on jungle trails, swamps, or on unimproved roads. Evacuation of patients by litter is a slow and exhausting task and usually will require the use of many nonmedical personnel. Tracked and wheeled vehicles, pack animals, rafts, boats, barges, litter bearers, or combinations thereof will be required in the evacuation of patients to augment organic evacuation means. Host nation personnel properly supervised by trained medical platoon personnel may be used as litter bearers.

3-185. There is a higher proportion of litter cases than ordinarily encountered since even a slightly wounded individual may find it impossible to struggle over rough terrain. As a result, the patient ordinarily classified as walking wounded may become a litter case.

3-186. The usual equipment and property prescribed by the TOE for units concerned with evacuation are not always suitable for operation under jungle conditions. For this reason, all types of transportation, whether by water, land, or air, may be used to transport patients to the rear. This principle applies not only to vehicles assigned primarily for this purpose but also to empty supply vehicles returning from forward positions. Evacuation in the jungle would normally be along supply routes which are generally protected against enemy action.

3-187. The standard folding litter has some advantages when evacuation involves the crossing of streams, gullies and steep slopes. Metal basket litters (mountain type) are more practicable under these conditions and can also be used to advantage when patients are being moved from jungle areas to ships for evacuation by water. The metal basket litter can be rigged to evacuate patients by pack animal. Host nation litter bearers may prefer to use ordinary canvas sheets with loops for poles. The canvas sheeting is light and poles may be cut when needed. All available means for collecting and transporting the sick and wounded must be used to do the job satisfactorily. Improvised litters can also be made from ponchos, shelter halves, fatigue jackets, parachutes, and woven vines on poles.

3-188. It is easy to overestimate the strength and endurance of litter squads. Well-conditioned men, carrying a patient on a litter for 365 to 550 meters (400 to 600 yards) over jungle terrain, are unable to repeat the performance without an appreciable amount of rest. The medical leadership must keep their commanders informed of the adequacy and efficiency of the evacuation system, and commanders must provide additional

natives when practicable and, at times, rotate men from other units of the command. No Soldier should be evacuated who may be treated locally and returned to duty.

3-189. There are other problems encountered in jungle operations. Personal hygiene and sanitation is a serious and continuous one as is the incidence of diseases peculiar to jungle areas. These diseases are transmitted in various ways: mosquitoes, ticks, flies, lice, mites, bats, and water. The incidence of fungal diseases of the skin is especially serious. In addition to maintaining high standards of personal hygiene and military sanitation, strict personnel protective measures per the unit TACSOP must be observed at all times.

3-190. The availability of trails, roads, and waterways, the density of natural growth, the season, and general terrain conditions all have a direct influence on medical operations in jungle areas. Supply requirements must be anticipated well in advance of actual needs and careful planning is necessary to conserve the aid station, including manpower.

3-191. The manner in which medical units support the tactical units depends on the employment of the supported unit. Wide variations in the amount and type of support may be expected at brigade level and below. The greatest variances will be found in the support of the light infantry battalion by the medical platoon and with the support of the BCT by the BSMC.

3-192. The medical platoon requires considerable augmentation when undertaking jungle operations. This is due to disease-causing humidity and heat, location of tactical units supported, difficulty of crossing terrain with patient loads, requirement to increase medical platoon personnel attached to the tactical companies being supported, and operating relatively independently. Plans to use host nation litter bearers, when available, should also be established prior to entry into combat.

3-193. Equipment may require modification to permit maximum efficiency in jungle operations. This may include establishment of pack equipment for all medical installations and the replacement of wheeled ambulances with other evacuation means appropriate for use in jungle terrain.

EVACUATION

3-194. The evacuation of wounded in jungle warfare presents numerous problems. Because of the prevalence of rapidly debilitating tropical diseases and the likelihood of quick infection of wounds, speedy evacuation is vital. Units must use all available methods to augment organic MEDEVAC means. These may include tracked or wheeled vehicles, pack animals, watercraft, helicopters, and litter bearers. Ground MEDEVAC in the jungle will normally be along supply routes, as they are usually given all possible protection from the enemy.

3-195. The difficulties of overland MEDEVAC in jungle operations emphasize the advantages of air evacuation. When weather, aircraft availability, and friendly air superiority permit their use, helicopters should be used to transport casualties. This reduces the time between injury and treatment, increases the chance of survival, and

raises morale. A helicopter equipped with a cable hoist system can evacuate casualties from thick jungle vegetation where no HLZs are available.

3-196. In some remote and densely foliated jungles, the only means of evacuation maybe by litter. This is a slow and exhausting task requiring well-conditioned Soldiers to carry the litters. At best, for only a few patients, aid and litter teams can provide fast, comfortable, and efficient evacuation through rough jungle terrain. Use of litter relays should be considered.

3-197. The Role 1 BAS should be as close as practicable to the troops to make litter evacuations as short as possible.

MEDICAL SUPPLIES (CLASS VIII INCLUDING MEDICAL REPAIR PARTS)

3-198. Consider your Class VIII resupply procedures. Distances, heat, and high humidity can cause deterioration of certain medical materials and medicines (for example, penicillin, hydrocortisone liquids, and sulfa liquids), frequent resupply and replacement of these items may be required. There will also be a priority need for refrigeration equipment to store Class VIII supplies. There will be an increased requirement for antiseptic material because the high heat and humidity increase the incidence of infection in wounds.

SECTION VII – ARMY HEALTH SYSTEM SUPPORT IN DESERT OPERATIONS

3-199. Deserts are arid, barren regions of earth incapable of supporting normal life due to lack of water; therefore, successful desert operations require adaptation to the environment and to the limitations its terrain and climate impose. Equipment and tactics must be modified and adapted to a dusty and rugged landscape. Temperatures vary from extreme highs down to freezing lows where visibility may change from 30 miles to 30 feet in a matter of minutes. Deserts are arid, barren regions of the earth incapable of supporting life due to lack of water. Temperatures vary according to latitude and season, from over 136 degrees Fahrenheit in the deserts of Mexico and Libya to the bitter cold of winter in the Gobi (East Asia). In some deserts, day-to-night temperature fluctuation exceeds 70 degrees Fahrenheit. There are three types of desert terrain: mountain, rocky plateau, and sandy or dune. Desert terrain also varies considerably from place to place with the sole common denominator being lack of water with its consequential environmental effects, such as sparse, if any, vegetation. The basic land forms are similar to those in other parts of the world, but the topsoil has been eroded due to a combination of lack of water, heat, and wind giving deserts their characteristic barren appearance. The bedrock may be covered by a flat layer of sand, or gravel, or may have been exposed by erosion. Other common features are sand dunes, escarpments, wadis, and depressions. This environment can profoundly affect military operations.

3-200. The burden on medical resources increases due to the intensity and lethality of offensive operations in the desert and the increased distances over which units require

support as a force advances. Medical units must anticipate large numbers of casualties over a large geographic area. Units should plan and rehearse nonstandard casualty evacuation procedures.

3-201. It is important to realize that deserts are affected by seasons. Those in the Southern Hemisphere have summer between 21 December and 21 March. This six-month difference from the United States is important when considering equipping and training Soldiers who are not acclimated for desert operations south of the equator. For more information on desert operations refer to ATP 3-90.99/MCTP 1-10D.

MEDICAL CONSIDERATIONS

3-202. The vast distances, increased lethality, and rapid pace of desert operations can burden medical resources and complicate casualty treatment and evacuation procedures. The potential for large numbers of casualties increases as formations maneuver across wide areas and exchange indirect fire without natural cover and concealment to protect forces. These mass casualty situations can exceed the capabilities of organic and direct support medical assets without careful planning and coordination. Casualty evacuation must occur concurrently with operations. Units that cease aggressive maneuver to evacuate casualties while in enemy contact often suffer additional casualties. Because of the greater distances involved and the high mobility of the maneuver elements, it will be necessary to augment the MEDEVAC capability with additional vehicles and personnel. Furthermore, augmentation by medical air ambulances is highly desirable.

3-203. Medical unit requirements for desert operations are essentially the same as for temperate climates. It is essential that each brigade has an environmental sanitation team attached. When planning for medical support the following factors should be considered:

- Identify external sources of medical support and augmentation, such as medical evacuation support, forward resuscitative and surgical teams, combat support and field hospitals, and Class VIII resupply procedures.
- Develop procedures for rapidly evacuating and triaging casualties to the appropriate role of care.
- Do medical personnel know the routes between units and echelons?
- Increased dispersion and large areas over which battles are fought increases vehicle evacuation time. This problem can be further complicated if the enemy does not recognize the protection of the Red Cross, thereby inhibiting air evacuation within the range of enemy air defense weapons. The importance of units having trained CLSs is critical to overcoming this. The reduction of the number of deaths due to slow evacuation time can be directly affected by the CLSs available. Units should attempt to train and maintain one CLS per combat vehicle.
- The comparatively long distances between units may limit the availability of combat medics to adequately support combat troops. Reinforcements may be required from the Role 2 BSMC or from supporting EAB medical units. Augmentation should include vehicles as well as personnel.

- The incidence of illness from heat injuries and diseases is higher than in temperate climates. Fevers, diarrhea, and vomiting, for example, cause loss of water and salt, which can culminate in heat illnesses. Cold weather injuries can also occur during a desert winter.
- The mobility required of maneuver units will be inhibited if movement of any part of these units, including trains, is restricted by having to hold a number of casualties; therefore, the wounded and sick must be evacuated immediately.

3-204. In order to properly treat patients, the aid station should be provided additional supplies of water. Medical platoon personnel must assist tactical commanders in preventing or reducing heat casualties within their units.

3-205. Brigade support medical company and EAB medical assets in support of the division should be augmented with extra ambulances from corps medical units and FRSDs. In an emergency, empty cargo vehicles (CASEVAC) moving to the rear can be used for evacuation.

3-206. Evacuation from the Role 1 BAS back to the brigade AXP or BSMC by ground or air ambulance, will be performed by ground or air transportation. Consider METT-TC considerations, availability of equipment, and the patient's condition in determining the method of transportation used to evacuate.

3-207. The effects of nuclear weapons can be expected to be greater in desert terrain. Introduction of nuclear weapons by the enemy will greatly increase casualties and severely strain available medical resources. The same effects can be expected if the enemy introduces chemical weapons against unprepared troops.

3-208. Medical training to include nonmedical personnel is very important. The medical platoon leadership can provide valuable information on the medical implications of operations in a desert environment. They advise the battalion commander on measures to take to ensure training includes operational public health concepts essential to keeping DNBI to a minimum. Burn casualties should also be a medical training consideration as these will be the most likely casualties in a armored/mechanized environment. Proper hydration should also be a training consideration. Disease and nonbattle injury patients, due to a lack of consideration of operational public health concepts, can far outnumber combat patients.

3-209. Inherent to the success of any tactical operation is a sound logistical plan. This includes medical planning. It is especially important in the desert because the greater distances used in maneuver and deployment complicate MEDEVAC and supply procedures.

3-210. Additionally, roads and trails are scarce, and they usually connect villages and oases. Tracked vehicles and most wheeled vehicles can generally travel in any direction over much of the desert and need not be confined to established roads and trails because much of the desert area is flat and hard surfaced, carpeted with only two or three centimeters of sand. Other complications are the shortages of water coupled with the increased demand created by very high temperatures and low humidity and the increased effort required to combat the effect of sand, dust, and heat on personnel and equipment.

COMMAND AND CONTROL

3-211. Prevention, which enhances the combat effectiveness of a command, requires constant supervision by responsible personnel. Commanders are responsible for proper sanitation and the enforcement of sanitary regulations within the boundaries of their organizations. Medical platoon leadership is responsible for making recommendations for the preservation of the health of the command and for the correction of unsanitary conditions.

3-212. Because the desert has extreme daily temperature ranges in all seasons, the commander must give careful attention to the protection of their Soldiers. The nights are cold, and heavy clothing and blankets may be needed, especially in winter when night temperatures often drop below freezing. Daytime temperatures range from 100 degrees Fahrenheit to 120 or 130 degrees Fahrenheit in summer.

3-213. Commanders must guard against the temptation for troops to throw away warm clothing during hot daytime hours and should, whenever possible, conduct operations during the night, or early or late daylight hours to avoid heat casualties.

EVACUATION

3-214. Evacuating casualties by ground across extended LOCs consumes valuable time and resources. When possible, planners establish HLZs forward to facilitate air evacuation of casualties and limit the burden on maneuver units. This enables freedom of action and supports the tempo and pace inherent to successful desert operations. It also prevents congesting LOCs with excessive two-way traffic and allows them to primarily be used to push heavy logistics packages forward that units could not move by air. When units do not have air evacuation available, commanders mitigate the excessive ground evacuation times by augmenting and distributing adequate medics throughout their formation and ensuring medics and Soldiers have been given additional training on how to provide TCCC at the POI prior to desert operations.

3-215. The large area over which a battle is fought presents special problems in the evacuation and treatment of patients. Any number of patients in a highly mobile unit restricts the action of that unit and may endanger it. Medical units at all roles of care may be located farther to the rear in the desert. Air evacuation by fixed-wing aircraft and helicopters is particularly valuable because of speed and the reduction of the load on ground vehicles.

3-216. Effectively managing large numbers of casualties requires clearly understood SOPs, rehearsals, adequate resources, rapid triage, and detailed patient tracking procedures. When developing the unit's health service support plan, medical planners—

- Identify external sources of medical support and augmentation, such as medical evacuation support, FRSDs, Role 3 MTFs, and Class VIII resupply procedures.
- Designate ambulance exchange points and HLZs to support air evacuation.
- Develop procedures for rapidly evacuating and triaging casualties to the appropriate role of care.

OPERATIONAL PUBLIC HEALTH AND SANITATION

3-217. Practically every disease of known military significance may be found in the desert among its human inhabitants, animals and insects, and locally available water and food supplies. Practically all of the communicable diseases will be prevalent among the native population. Insect borne diseases such as malaria, sand-fly fever, leishmaniasis, typhus and plague may be found. The cold of the desert night, even in summer, may require warm clothing, and actual cold injury may occur during the desert winter. It is the desert sunshine, wind, and heat however that have the greatest effect upon military operations. The dryness of desert heat distinguishes it from the heat of the tropics and adds to the problem of coping with it. Proper operational public health and sanitation measures, adequate personal hygiene, avoidance of native villages and constant command supervision will reduce the incidence of disease and disability.

EYES AND SKIN

3-218. The eyes may be protected from the intense sun light and wind driven sand by tinted goggles, however, these will not completely protect tank/vehicle drivers and others constantly exposed to the sun and wind from damage to their eyes. Closed, tight-fitting goggles are required to prevent eye damage from dust. Blackening the area around the eyes reduces the effect of glare and improves distance vision and adaption to night vision goggles. The desert wind dries exposed skin surfaces and causes chapping of the lips and other local skin irritation of a near disabling nature. Cuts and scratches become infected very easily. Lip balm and protective ointments will provide some protection against these conditions. Severe sunburn may result from short periods of exposure to the desert sun, therefore, Soldiers must protect themselves from direct rays of the sun.

WATER

3-219. Disease and illness in desert environments can cause more than the usual amounts of disability because of the added effects of dehydration. Fever that accompanies infections causes an increased loss of water, while diarrhea and vomiting cause the loss of both water and salts (electrolytes) from the body.

3-220. Consider all water not received from approved water sources to be contaminated and unfit for drinking, bathing, or the washing of clothing. Natural water, when it is drunk, will transmit such diseases as dysentery, typhoid fever, and infectious hepatitis. Parasitic diseases such as schistosomiasis (snail fever) and leptospirosis, may be acquired by wading, swimming, bathing, or washing clothes in irrigation ditches or other bodies of water. Chemical contaminants in water may cause skin irritation or dermatitis.

3-221. Water discipline must become a part of every Soldier's daily life. Soldiers must be trained to conserve water, to drink from only approved water sources, to not pollute or contaminate available water sources. Even after acclimatization, Soldiers cannot condition their bodies to require less water than is lost by sweating. A Soldier physically active at hard work for 8 hours per day in a daily mean temperature of 120 degree

Fahrenheit may require up to 25 quarts of water per day and at 100 degrees Fahrenheit, about 15 quarts per day. This exceeds the daily maximum amount of fluid consumption of 12 quarts, so adherence to work/rest cycles and water consumption recommendations (Table 5-5 on page 5-36) should be followed. Any restriction of water below the amount needed for efficient cooling of the body will result in rapid loss of efficiency, reduction in work ability and deterioration of morale. Water restriction continued for several hours can result in heat injuries.

FOOD SERVICE SANITATION

3-222. Intestinal diseases tend to increase among personnel living in the desert. This may be prevented by proper food service sanitation including proper cleaning of eating and cooking utensils, adequate supervision of food handlers, proper disposal of garbage and human wastes, and protection of foods and utensils from the swarms of flies that are found everywhere. Germicidal rinses should be used for washing food service and kitchen gear when water is scarce or cannot be heated because of the enemy situation. Solid waste should be burned as the situation permits. Soakage pits should be used to dispose of liquid wastes and should be filled with soil when leaving an area.

WASTE DISPOSAL

3-223. Trench type latrines should be used if the soil is suitable. Shallow latrines become exposed in areas of shifting sands.

INSECT AND RODENT CONTROL

3-224. Insects and rodents must be controlled if the diseases they carry are to be prevented. Personnel protective measures used when insects and rodents are not controlled include protective clothing, clothing impregnating, insect repellents, residual and space sprays, immunizations and suppressive drugs.

PERSONAL HYGIENE

3-225. Commanders must ensure that the proper standards of personal hygiene are maintained. Foot hygiene must be stressed to ensure daily washing of feet, changing of socks, and use of foot powder by all personnel. Daily shaving and bathing should be required when sufficient water is available. If sufficient water is not available for bathing, troops may clean themselves by sponge baths or by rubbing themselves with a damp or even a dry cloth. When water is not available for laundering, soiled clothing may still be worn if it is changed frequently and dried in the sun and wind.

SECTION VIII – ARMY HEALTH SYSTEM SUPPORT TO URBAN OPERATIONS

3-226. Urban terrain provides numerous advantages to the urban defender. Due to this advantage, casualties in urban terrain are more likely than in other types of operations. Casualties are more difficult to prevent in urban stability operations because of the dense

complex terrain, the proximity of the urban population, and the difficulty indistinguishing friend from foe. In urban offense and defense, friendly and threat forces engage at close range with little space to maneuver. Higher casualties occur among troops on the offensive where frontal assaults are often the only tactical option. Defenders with limited ability to withdraw suffer high casualties when isolated and attacked. The potential for high casualties and the subsequent need for CASEVAC under difficult circumstances make the positioning and availability of adequate medical resources another important consideration. Additionally, high intensity urban combat and the potential for increased stress casualties require additional units to allow for adequate unit rotations so that Soldiers receive the rest they require.

3-227. Commanders conducting urban stability operations must know the casualty risk and its correlation to national and strategic objectives. While a lower risk normally exists in stability operations than in offensive or defensive operations, just one casualty may adversely impact the success of the stability mission. A realistic understanding of the risk and the nature of casualties resulting from urban operations critically affect the decision-making process. If commanders assess the casualty risk as high, they must ensure that their higher headquarters understands their assessment and that the objectives within the urban area are equal to the anticipated risk. See ATP 3-06, ATP 3-06.11, and TC 90-1 for more information on urban operations.

HEALTH SERVICE SUPPORT CONSIDERATIONS

3-228. Enemy actions and the maneuver of forces complicate forward area medical operations. Health service support considerations for defensive operations in urban terrain are—

- Medical platoon personnel have less time to reach the patient, complete vital EMT, and remove the patient from the battle site.
- The enemy's initial attack and the maneuver battalion's counterattack produce the heaviest patient workload. These are also the most likely times for enemy use of artillery and CBRN weapons.
- The enemy attack can disrupt ground and air routes and delay evacuation of patients to and from treatment elements.
- The depth and dispersion of the defense create significant time-distance problems for evacuation units.
- The enemy may exercise the initiative early in the operation, which could preclude accurate prediction of initial areas of casualty density. This fact makes effective integration of air assets into the MEDEVAC plan essential.

OTHER MEDICAL URBAN CONSIDERATIONS

3-229. Other medical considerations to be considered in urban terrain are:

- Are medical services available and operational?
- Does an emergency service exist?
- Do emergency services use radio communications? If so, which frequencies do they use?

- Are services available for animals?

SECTION IX – ARMY HEALTH SYSTEM SUPPORT TO SUBTERRANEAN OPERATIONS

3-230. Health threats common to underground facility and subterranean environments include disease, trauma, and BH issues. It is important to note that there are no differences in how injuries sustained in subterranean operations and those in any other OE are treated. See ATP 3-21.51 for more information on subterranean operations.

3-231. However, there are conditions common to underground facility and subterranean environments that have the potential to increase the number of casualties, the severity of wounds, and the psychological stress and its impact on Soldiers operating in these environments. These conditions include—

- Confined spaces.
- Little or no light.
- Fear of being trapped or buried alive.
- Lack of cover or concealment.
- Disorienting in both time and space.

EFFECTS OF OPERATING IN CONFINED SPACES COMBINED WITH LITTLE OR NO LIGHT

3-232. Conducting combat operations in confined spaces with little or no ambient light has the potential to increase both the type and severity of traumatic injuries. Combat and operational stress reactions experienced by Soldiers operating in these environments tend to increase significantly as well.

3-233. The physical effects of fighting in confined spaces constructed from concrete, stone, or densely packed earth are of particular concern. The primary physical risk is associated with blast waves from explosives neither absorbed nor attenuated by the environment. The subterranean environment amplifies and directs their wounding effects outward for great distances. Other physical risks from the environment include reduced air quality and concentrated exposure to toxic gases from weapon systems or other sources (natural and manmade). The construction material of the facility (concrete versus dirt) also has the potential to increased wounding effects of small arms to Soldiers through spall and ricocheting small arms projectiles.

3-234. The psychological effects of fighting in confined spaces with little or no ambient light may include cases of claustrophobia or increased severity of COSRs.

DISEASE

3-235. Soldiers can encounter numerous diseases in underground facilities and subterranean environments including:

- Hanta virus.
- Histoplasmosis.

- Rabies.
- Marburg hemorrhagic fever.
- Leptospirosis.
- Tick-borne relapsing fever.
- Other arthropod-borne diseases.

TRAUMA

3-236. Traumatic injuries may be encountered in underground facilities and subterranean environments including:

- Asphyxiation.
- Abrasions.
- Ballistic injuries (bullet wounds, secondary fragment wounds).
- Blast overpressure injuries.
- Burns.
- CBRN agents (toxic industrial materials and chemicals).
- Contusions.
- Crush injuries.
- Dust impaction injury.
- Fractures.
- Lacerations.
- Rodent bites.
- Snake bites.
- Spider bites.
- Sprains.
- Strains.
- Traumatic brain injury.

BEHAVIORAL HEALTH ISSUES

3-237. Soldiers encounter BH issues in underground facilities and subterranean environments including:

- Claustrophobia.
- Combat and operational stress reactions.
- Survivor's guilt.
- Moral injury.

EMOTIONAL, MORAL, AND SPIRITUAL HEALTH ISSUES

3-238. Psychosocial research regarding subterranean spaces identifies four major issues of concern for Soldiers in subterranean spaces: isolation, perceived control, negative culture-based associations, and perceived security. The spiritual,

philosophical, and psychological frameworks shaping a Soldier's culture, Soldiers, and professional ethos influence the effectiveness of units in a subterranean space. Subterranean environments may reduce a Soldier's sense of purpose and commitment, causing him to lose combat effectiveness sooner than anticipated due to the psychological and physiological stress of these environments.

3-239. Understanding how Soldiers respond to operations in subterranean environments requires consideration of spiritual, philosophical, and cultural perspectives. Most perspectives provide a concept of the afterlife, underworld, or death that includes some form of darkness, isolation, and lack of control. As a result, Soldiers may have powerful emotional reactions. These may include an overwhelming sense of fear or momentary loss of their moral compass leading to illegal or immoral actions.

3-240. Unprepared and untrained units and Soldiers lacking professional ethics, trust, and positive unit climates could exhibit a propensity for immoral and unethical decisions and actions creating increased potential for moral injury and post-traumatic stress. Training focused on character formation, moral leadership, and ethical reasoning under dynamic and complex conditions increases moral courage and commitment to the Army ethic, thereby fostering increased endurance and post-operations well-being. Chaplain sections and unit ministry teams can support this type of training (see FM 1-05 and ATP 1-05.04 for more information).

BLAST INJURIES

3-241. Blast injuries, especially blast overpressure injuries, present unique challenges to leaders and medical platoon personnel conducting combat operations in underground facilities and subterranean environments. Anytime Soldiers are in close proximity to an explosion in an underground facility or subterranean environment, personnel must be suspected as having sustained blast overpressure injuries (see table 3-5 on page 3-57).

3-242. In a subterranean environment, with substantial risks for overpressure injuries, it is crucial to perform traumatic brain injury screenings as quickly as possible. It can often be under recognized, given the more obvious severity of other injuries which are likely to be incurred. When exposed to a potentially traumatic brain injury causing event, it is imperative for Soldiers to be quickly evaluated and evacuated to an appropriate role of care to minimize brain damage and potentially death. (See table 3-5 on page 3-58).

Note. Up to 10 percent of all blast survivors have significant eye injuries. These injuries involve perforations from high-velocity projectiles that can occur with minimal initial discomfort and may present days, weeks, or months after the event. Symptoms include eye pain or irritation, foreign body sensation, altered vision, periorbital swelling, or contusions. Findings can include decreased visual acuity, hyphemia, globe perforation, subconjunctival hemorrhage, foreign body, or lid lacerations. Liberal referral for ophthalmologic screening is encouraged.

Table 3-5. Medical considerations for blast injuries

<ul style="list-style-type: none"> • Clinical signs of blast-related abdominal injuries can be initially silent until signs of acute abdomen or sepsis are advanced. 								
<ul style="list-style-type: none"> • Standard penetrating and blunt trauma to any surface of the body is the most common injury seen among survivors. Primary blast lung and blast abdomen are associated with a high mortality rate. "Blast lung" is the most common fatal injury among initial survivors. 								
<ul style="list-style-type: none"> • Blast lung presents soon after exposure. Confirmed by finding a "butterfly" pattern on chest X-ray. Prophylactic chest tubes (thoracotomy) are recommended prior to general anesthesia or air transport. 								
<ul style="list-style-type: none"> • Medics may overlook auditory system injuries and concussions. 								
<ul style="list-style-type: none"> • The symptoms of mild TBI and post-traumatic stress disorder can be identical. 								
<ul style="list-style-type: none"> • Isolated TM rupture is not a marker of morbidity; however, traumatic amputation of any limb is a marker for multi-system injuries. 								
<ul style="list-style-type: none"> • Air embolism is common, and can present as stroke, myocardial infarction, acute abdomen, blindness, deafness, spinal cord injury, or claudication. Hyperbaric oxygen therapy may be effective in some cases. 								
<ul style="list-style-type: none"> • Compartment syndrome, rhabdomyolysis, and acute renal failure are associated with structural collapse, prolonged extrication, severe burns, and some poisonings. 								
<ul style="list-style-type: none"> • Consider the possibility of exposure to inhaled toxins and poisonings (for example, CO and CN) released by explosives. 								
<ul style="list-style-type: none"> • Wounds can be contaminated. Consider delayed primary closure and assess tetanus status. 								
<ul style="list-style-type: none"> • Ensure close follow-up of wounds, head injuries, eye, ear, and stress-related complaints. 								
<ul style="list-style-type: none"> • Medics may need to write instructions to communicate with patients due to tinnitus and sudden temporary or permanent deafness. 								
<p>Legend:</p> <table> <tr> <td>CN</td> <td>tear gas</td> <td>TBI</td> <td>traumatic brain injury</td> </tr> <tr> <td>CO</td> <td>carbon monoxide</td> <td>TM</td> <td>tympanic membrane</td> </tr> </table>	CN	tear gas	TBI	traumatic brain injury	CO	carbon monoxide	TM	tympanic membrane
CN	tear gas	TBI	traumatic brain injury					
CO	carbon monoxide	TM	tympanic membrane					

SECTION X – ARMY HEALTH SYSTEM SUPPORT TO WET GAP CROSSING OPERATIONS

3-243. A river exerts decisive influence on the utilization of the BAS. Attacks across a river line create a medical problem similar to that of an amphibious assault. The Role 1 BAS should cross the river as soon as combat operations permit to provide prompt treatment to the heavy patient load anticipated early in the attack and to minimize cross river evacuation. Maximum possible use is made of air evacuation assets to preclude excessive buildup of patients in the far shore treatment assets. Near shore treatment assets are placed as far forward as assault operations and protective considerations allow to reduce ambulance shuttle distances from off-loading points. In defensive operations, medical resources deployed on the far shore are restricted to the absolute minimum needed to provide effective support. Evacuation of far shore treatment assets are expedited, utilizing amphibious, ground, and air evacuation, so as to preclude excess accumulation of patients forward of the wet gap barrier. Near shore treatment assets are

located farther to the rear than in the attack to preclude their having to displace in a cross-river withdrawal.

CONSIDERATIONS INFLUENCING ARMY HEALTH SYSTEM SUPPORT

3-244. Medical support in the attack of wet gap crossings, while conforming in general to AHS support doctrine of offensive operations, presents certain special problems incident to ferrying and bridging operations. Army Health System support must concern itself with the support of the combat troops during the advance to the wet gap (preliminary phase), during the crossing of the wet gap and the capture of the initial objective (phase I), during the operations incident to the seizure of the intermediate objective (phase II), and during the attack to gain the bridgehead (phase III).

PRELIMINARY PHASE

3-245. There are relatively few patients resulting from this phase as long as secrecy in movement to the wet gap is maintained. Casualty collections points may or may not be established along the main approaches to the wet gap crossing sites for the care of the wounded, sick, or injured.

PHASE I

3-246. At the end of the preliminary phase, the Role 1 BAS and any attached Role 2 BSMC treatment teams are established to render normal medical support in the area of each crossing. Aid and litter teams attached to each treatment team may be employed near each crossing site. Ambulances are advanced as near to the wet gap as possible, and these locations should be in positions that afford protection from direct enemy fire.

3-247. Medical platoons will provide close support to their respective units. Combat medics accompany their respective companies in the crossing. Combat medics and their supporting ambulance team (mounted or dismounted) cross in succeeding waves. These medics and ambulance teams establish support on the far bank as soon as the situation permits. Initially, patients are placed on returning craft for evacuation to the near bank where the BAS is located. When helicopters are employed as a means of air landing assault troops, the returning aircraft may be utilized to furnish rapid evacuation of patients to treatment teams on the near bank. After the establishment of the medical platoon on the far bank, patients are held until transportation to the near bank is available.

3-248. Aid and litter teams remove patients from returning craft and carry them to ambulances or to a designated collecting point for further movement to the Role 1 BAS or Role 2 BSMC.

3-249. Mission, enemy, terrain, troops, time, and civilian consideration dependent, air ambulance elements provide evacuation of patients from the far bank. Normally, this is after the BAS has been established on the far bank.

3-250. At the end of phase I, the BAS will have been established on or beyond the far bank. Patients are then evacuated from the platoon by amphibious, ground, or air means.

PHASE II

3-251. During this phase, elements of the supporting Role 2 BSMC evacuation platoon are providing MEDEVAC on both banks of the river until the BSMC has been established on the far bank. The BSMC may displace forward to a point nearer the wet gap during this phase.

3-252. When phase II has been completed, the Role 2 BSMC should be moved forward to a position either close to the near bank or across to the far bank as conditions dictate. A relatively high priority should be granted to the elements of the Role 2 BSMC for movement across any established and intact bridges. In the absence of functioning bridges, movement of medical elements by surface craft may be authorized.

PHASE III

3-253. During this final phase, medical units move across the wet gap as rapidly as possible and resume normal operating conditions on the far bank. The EAB medical units may be called upon to care for large numbers of patients destined for movement out of the battalion and brigade area. This will depend on the establishment of ample bridge facilities and the resumption of normal evacuation by higher headquarters.

SECTION XI – ARMY HEALTH SYSTEM SUPPORT TO AIR ASSAULT OPERATIONS

3-254. *Air assault* is the movement of friendly assault forces by rotary-wing or tiltrotor aircraft to engage and destroy enemy forces or to seize and hold key terrain (JP 3-18). For more information on air assault operations refer to FM 3-99.

THE AIR ASSAULT DIVISION

3-255. The air assault division combines strategic deployability with tactical mobility within its AO. It attacks the enemy deep, fast, and often over extended distances and terrain obstacles. The air assault division must be able to conduct forced entry operations. Air assault operations have evolved into combat and sustainment elements (aircraft and troops) deliberately task-organized for tactical operations. Helicopters are completely integrated into ground force operations. Air assault operations generally involve insertions and extractions under hostile conditions, as opposed to mere air movement of troops to and from secure locations about the battlefield. Once deployed on the ground, air assault infantry battalions fight like battalions in other infantry divisions; however, normal TASKORG of organic aviation results in greater combat power and permits rapid aerial redeployment. The rapid tempo of operations over extended ranges enables the division commander to rapidly seize and maintain the tactical initiative. For more information on division organizational structure see FM 3-94 and ATP 3-91.

3-256. The air assault division is ideally suited for rapid employment to critical areas beyond the reach of ground forces. Successive execution of air assault operations allows the commander to seize and maintain the initiative at the tactical level. The division has the ability to—

- Attack from any direction in otherwise inaccessible areas.
- Overfly barriers and bypass enemy positions in order to surprise the enemy and cause him to react prematurely or disclose their position.
- Concentrate, disperse, or redeploy rapidly to extend the division's area of influence develop enemy contact, or decrease its vulnerability to enemy attack.
- Maintain a rapid tempo of operations.
- Conduct combat operations under unfavorable weather conditions and at night to facilitate deception and surprise.
- Conduct airhead operations without external support for 48 hours.

3-257. The air assault division is organized with three maneuver brigades. It contains the necessary combat and sustainment organizations. However, the air assault division has some limitations—

- Helicopters cannot fly in extremely severe weather conditions.
- The division is vulnerable to enemy tactical aircraft, air defense, and electronic warfare systems.
- It possesses little organic ground transportation assets.
- The division has limited capabilities to operate in a CBRN environment.
- The division is not intended to meet a heavy threat force in open terrain; however, it possesses capabilities unique from other light divisions which minimize this limitation.

3-258. Air assaults differ from conventional missions in planning in that it is unlikely all or even most of the platoon's vehicles will be able to be sling loaded in to support the initial operation. Treatment-teams can best operate dismounted, maneuvering with rifle companies. A treatment team from the Role 2 BSMC can reinforce the third maneuver company. The supported unit must delineate areas of responsibility based on proximity to support slice, specialty platoons, and C2 nodes, which often move with rifle companies during the initial phases of the operation. Casualties are generally evacuated directly from the company CCPs to the Role 2 BSMC or even Role 3 hospital center or field hospital when appropriate. Remember to plan transition into support of the follow-on ground tactical plan after the assault objectives have been secured.

AIR ASSAULT MEDICAL AND CASUALTY EVACUATION

3-259. Medical evacuation refers to both air and ground CASEVAC. Air MEDEVAC employs air assets from the air ambulance companies assigned to the combat aviation brigade and air MEDEVAC general support aviation battalions to evacuate casualties. Dedicated air MEDEVAC aircraft include specifically trained medical personnel to

provide en route care. The nine-line MEDEVAC request is the standard method to request MEDEVAC. The supported unit uses CASEVAC only when the number of casualties exceeds the MEDEVAC assets or when the urgency of evacuation exceeds the risk of waiting for MEDEVAC assets to arrive. Typically, air assaults plan for both air and ground evacuations. See FM 3-04 and ATP 4-02.2 for more information.

MEDICAL EVACUATION PLANNING

3-260. The combat aviation brigade normally allocates AE assets to the supported brigade and/or air assault task force (AATF) while it is conducting air assault operations. However, the size and distance of the planned air assault dictates the duration of MEDEVAC support to the AATF. As a rule, the supporting commander should provide MEDEVAC assets to the supported commander until ground lines of communications are established.

3-261. Typically, the evacuation platoon leader from the BSMC and the forward support MEDEVAC platoon (FSMP) platoon leader from the medical company, air ambulance conduct the MEDEVAC planning for the air assault. They do so in coordination with the AATF personnel staff, AATF logistics staff, brigade aviation element, AATF operations staff, supported unit operations staff, BCT surgeon section, and BSMC company commander. The FSMP platoon leader should brief the MEDEVAC plan at the air mission coordination meeting, the air mission brief, and during the aviation and sustainment rehearsals.

3-262. Planning for MEDEVAC during an air assault should—

- Integrate ground evacuation measures into the overall MEDEVAC plan.
- Plan MEDEVAC routes to Roles 1 through 3. Ensure all aircrews participating in the air assault know these routes.
- Plan for medical platoon personnel to fly on CASEVAC aircraft if time and situation permit.
- Ensure MEDEVAC crews are available for air assault orders, rehearsals, and preparations.
- Brief CCP locations and markings during the air assault rehearsal.
- Plan to maintain a forward arming and refueling point after the air assault is completed so that MEDEVAC aircraft have a staging place for follow-on ground tactical operations.

3-263. Medical evacuation aircraft are limited assets and should be scheduled and used accordingly. The brigade and/or AATF's casualty estimate provides planning guidance for the number of MEDEVAC aircraft needed to support the air assault. To maximize the number of hours they can support the mission, personnel should stage MEDEVAC aircraft to support an air assault at the latest possible time. Medical evacuation aircraft should support short distance air assaults from the pickup zone (PZ) or BSA. Aircraft may stage at a forward arming and refueling point or use a restricted operations zone to expedite pick up of casualties in long distance air assaults.

MEDICAL AND CASUALTY EVACUATION

3-264. Medical evacuation and CASEVAC aircraft normally are under operational control to the AATF during air assault operations. The air mission commander (AMC) controls the MEDEVAC flights to facilitate quick deconfliction of airspace. The AMC clears all MEDEVAC and CASEVAC aircraft movements, to include launch and landings. The AATF commander may retain launch authority, but the AMC is responsible for MEDEVAC.

3-265. Typically, requests for medical or CASEVAC is over the combat aviation network for the duration of the air assault operation until an evacuation network, if necessary, is established. This ensures good coordination for deconfliction of fires and airspace. When planning MEDEVAC operations—

- Send MEDEVAC aircraft into secure LZs if possible.
- Integrate attack reconnaissance aviation units to provide escort and LZ overwatch as required.
- Ensure terminal guidance into the LZ.
- Ensure redundant means of communication with the supporting MEDEVAC assets throughout the air assault.
- Designate a MEDEVAC officer in charge, typically a medical officer from the BSMC, to ride on command and control aircraft to receive and prioritize evacuation mission requests and forward this information to the AMC for launch.

CASUALTY BACKHAUL

3-266. The AATF staff and aviation unit staff plan the combined use of aerial and ground medical and CASEVAC assets during air assault planning. While assaulting aircraft may backhaul wounded from the LZ, the time required to load and unload casualties could desynchronize the air movement table.

3-267. Casualty evacuation may cause delays in air assault missions unless spare aircraft are committed to replace aircraft designated to backhaul casualties. Designating separate CASEVASC aircraft may prevent delays of follow-on lifts. Procedures for casualty backhaul during an air assault are:

- Medical evacuation request goes to command and control aircraft. The medical officer onboard relays the request to the AMC. If approved, the AMC directs the next serial's last two aircraft (dependent on METT-TC) to move to the LZ CCP to pick up casualties after dropping off personnel.
- All backhauled casualties are taken back to the PZ CCP.
- Backhaul aircraft with casualties notify PZ control they are inbound with casualties.
- Last serial of the final lift makes the final pick up of casualties before the conclusion of the air assault, if necessary.

MEDICAL EVACUATION LANDING ZONE

3-268. During air assault planning, the AATF staff and AMC plan the combined use of air MEDEVAC and aerial CASEVAC LZs. The AATF plans a means of marking the CCP for air medical or assault aircrew identification. Preferred LZ signaling methods include smoke or panel markers (VS17 panel marker) during the day and strobe or chemical lights (not blue or green which are not visible under night vision goggles) at night. If air assault crews evacuate casualties, they must know where to take them and how to rejoin remaining lift aircraft for subsequent lifts. Using a backhaul LZ within the normal assault PZ, forward arming and refueling point, or both can minimize disruption of the loading plan while helping maintain serial integrity.

3-269. Medical evacuation LZ selection and procedures include:

- A dedicated MEDEVAC LZ may be used for both air medical and aerial CASEVAC.
- Select LZs that are level and clear of debris within a 50-meter radius.
- Light sources must be kept away from the LZ unless instructed otherwise by aircrew.
- Inbound MEDEVAC aircraft must have an estimated time-of-arrival call.
- Personnel communicating with the aircraft at the pickup site have visual on the LZ to confirm the signal or to assist the crew as required.
- When MEDEVAC aircraft has landed, if manned with medical personnel to provide en route care, and keep all other personnel away from the aircraft while the medical personnel come to the patient.
- The unit should provide personnel to assist in loading the patient on the aircraft, and if present, under direction of medical personnel.

SECTION XII – ARMY HEALTH SYSTEM SUPPORT TO AIRBORNE OPERATIONS

3-270. Airborne (forced entry) operations are similar to air assault. If any significant resistance is expected, a third treatment team will probably be required to support the third rifle company if assault objective proximity will not support manual collection of casualties to the nearest treatment team (500m is realistic). Units cannot depend on heavy drop vehicles or air lands to be available to provide timely support for those injured during the initial assault. Maximize use of nonstandard vehicles to assist in casualty collection. For more information on airborne operation refer to FM 3-99.

THE AIRBORNE DIVISION

3-271. The airborne division can rapidly deploy anywhere in the world to seize, retain, exploit, and secure vital objectives. The airborne division must be able to conduct forced entry operations. It conducts parachute assaults to capture initial lodgments, execute large-scale tactical raids, secure intermediate staging bases or forward operating bases for ground and air operations, or rescue United States nationals besieged overseas. It also can serve as a strategic or theater reserve as well as reinforcement for forward

presence forces. The airborne division can assault deep into the enemy's support areas to secure terrain or interdict enemy supply and withdrawal routes. It can seize and repair airfields to provide a forward operating base and airheads for follow-on air-landed forces. It is capable of all other missions assigned to light infantry divisions. The airborne division uses its strategic and operational mobility to achieve surprise on the battlefield. The United States Air Force can accurately deliver the airborne division into virtually any objective area under almost any weather condition. All equipment is air transportable; most are air-droppable. All personnel are trained for parachute assaults and airborne operations. Engagements with enemy armored or motorized formations require special consideration. The division does not have sufficient armored protection to defeat heavier armored formations at close range. Antitank weapons in the division compensate for, but do not completely offset, this deficit. For division organizational structure, see FM 3-94 and ATP 3-91.

3-272. Since there are generally not enough aircraft available to insert an airborne division in a single wave or assault, the division is not able to deploy its entire strength of paratroopers and support elements during the initial phases of the operation. Consequently, the division will deploy assault forces in echelons in order to continually reinforce/expand the objective area. This places an added burden upon medical support planners in determining how to support the operation with only a portion of their personnel and equipment during the early phases of the operation.

3-273. Airborne forces are special assets used at a time and place where they have a calculated advantage. They are not primarily intended to be used as "extra infantry," nor are they intentionally used in situations or on terrain where enemy capability reduces the shock or surprise of a strategic or tactical airborne assault.

3-274. The airborne division is organized with three airborne maneuver brigades. It contains the necessary combat support and sustainment organizations. It is the only division with the immediate capability to conduct parachute assaults. However, the airborne division does have some limitations. It—

- Relies on United States Air Force tactical or strategic airlift for initial entry and resupply.
- Requires more close air support than that normally provided to other type divisions because it is organized with only light field artillery.
- Limits ground and air mobility once delivered into the objective area.
- Reveals its vulnerabilities to attack by enemy armor or motorized formations.
- Depends on AE of casualties when units are isolated.

DEPLOYMENT AND EMPLOYMENT OF THE AIRBORNE MEDICAL PLATOON

3-275. Personnel protective measures, which may be adopted for protection against certain endemic diseases, will be taken prior to deployment of the force. All paratroopers will be trained on personnel protective measures and casualty response skills will be reconfirmed.

PREDEPLOYMENT

3-276. Prior to the insertion of the airborne medical platoon into an AO, the division brigade, and battalion personnel staffs will make an initial casualty estimate. This estimate will include a consideration of endemic disease hazards as well as the nature of the threat posed by the enemy forces.

3-277. A casualty estimate of the likely battle casualty rate and the major combat stress and disease threats will dictate the extent of initial and subsequent medical support required by the medical platoon.

3-278. Medical platoon personnel are loaded onto several aircraft so that the loss of one aircraft will not restrict unit level HSS. Combat medics and their basic load ride in the aircraft with the supported unit to which they are attached. When feasible, an ambulance team should be included in assault loads of each airborne rifle and weapons company. The treatment squad should not be loaded on one aircraft. Ideally, the two teams should be loaded on separate aircraft, along with their basic load. This facilitates their reconstitution or replacement in the event they are lost, and does not degrade medical support capabilities. Once the objective is secured, medical platoon personnel should pack their airborne load out with medically appropriate equipment and supplies in order to treat casualties. The medical platoon should plan for cross loading medical equipment and supplies within the platoon and designate multiple teams for aid.

3-279. Medical support in the marshalling areas is provided by division and/or EAB medical units. Medical platoon personnel are not used since all supplies and equipment have been packed and prepared for the assault.

INITIAL DEPLOYMENT

3-280. During the initial phases of the attack, there will be a heavy dependence on unit level medical resources, and medical care must be provided promptly and efficiently. In addition to casualties caused by enemy fire, jump injuries, and crash victims will require care in the drop/LZ. When it is anticipated that the numbers of battle casualties may exceed the capability of the medical platoon, augmentation will be provided by the Role 2 BSMC. Treatment or ambulance squads from the BSMC may be attached to maneuver battalions likely to sustain heavy casualties. Surgical support to the brigade in the form of an attached FRSD may be attached to the Role 2 BSMC.

3-281. Initially, the FRSD will be task-organized to augment the Role 2 BSMC in the BSA where their services are most required. With the FRSD's capability to split into two surgical sections, a battalion serving as the main effort may be assigned a 10 person forward resuscitative and surgical section, METT-TC dependent.

3-282. Initial life-saving casualty response measures will be in the form of self-aid/buddy aid and those tasks performed by the CLS. Combat medics will provide TCCC and move with the unit. The casualty may be moved to the BAS, treatment team, or to CCPs to await evacuation. Casualty collection points should be well marked and located near suitable landing sites to facilitate evacuation by air, if possible.

3-283. Ambulances may not be available until air-land operations begin due to lack of air-droppable platforms; as such, a robust CASEVAC plan should be planned for. When available, ambulances from the medical platoon's ambulance section will transport patients from the POI or CCPs to the BAS. Nonmedical personnel may act as litter bearers and the use of nonmedical vehicles and aircraft for evacuation (CASEVAC) may be necessary. Patients requiring further treatment will be moved by ground and/or air ambulances to the BSMC in the BSA. All patients who can be treated and RTD in their unit will be managed in this way; no unnecessary evacuation will occur.

3-284. The BAS will be located in the battalion assembly area, and it will move with the battalion in accordance with the tactical situation.

3-285. During this phase, casualties requiring evacuation from the airhead are assembled near landing strips and airlifted directly to the Role 3 hospital center of field hospital in general support of the brigade and/or division. Normally, this activity will be coordinated between the brigade and division surgeons; however, the brigade surgeon may arrange such evacuation, if required.

3-286. The arrival of vehicles and additional equipment by air delivery, air landing, or ground linkup, medical support to the battalion resembles that of any ground operation. As the remainder of the airborne division's combat units deploy, sustainment units will also move into the AO. At this time the BSMC will consolidate its resources into the BSA, METT-TC depend.

MEDICAL EVACUATION IN AIRBORNE OPERATIONS

3-287. When necessary, evacuation may be provided by any one or a combination of methods between the Role 2 BSMC and the supported Role 1 BAS. The choice is affected by several factors all relating to the tactical situation—

- Availability of routes.
- Traffic density on available routes.
- Time and distance factors.
- Proximity of routes to terrain features or installations that may draw enemy fire.
- Protection from enemy observation and fire.
- Cover and concealment for moving and stationary ambulances.
- Areas contaminated with CBRN agents.

3-288. An ambulance team from the medical platoon is normally employed in direct support of a committed airborne rifle company (METT-TC dependent) and are responsible for evacuating patients from the CCP to the BAS. Ambulance exchange points are normally established between the Role 2 BSMC and the Role 1 BAS and used by ambulance teams of the BSMC. Casualties are moved to the AXP by augmented BSMC ambulance teams located at the BAS. They are then transferred to waiting BSMC ambulances and transported to the BSMC.

3-289. Ambulance infiltration is the dispatch of ambulances singly or in small groups. The ambulances travel over predetermined routes between the Role 1 BAS and the

supporting Role 2 BSMC, making round trips to move patients. This method provides for maximum dispersion of brigade ambulance assets.

3-290. An ambulance shuttle consists of one or more forward ambulance relay posts, a base relay post, and control points as may be required. Empty ambulances positioned at the various relay posts are from the ambulance platoon of the supporting BSMC. The base relay post is normally the BSMC ambulance platoon headquarters where unemployed ambulances are stationed, ready to move forward as required. As an ambulance from a relay post moves forward to the BAS to pick up casualties and transport them to the BSA, ambulances from the base relay post are moved forward to replace them at the forward relay posts. This method requires close coordination between all ambulances and control points to ensure that ambulances will be moving forward as others move rearward. When a shuttle system is not used, ambulances are dispatched from the base point on request of the BAS. This method is sometimes referred to as an “on call” system.

3-291. Because the disposition of brigade MEDEVAC elements may reveal/indicate the disposition of combat units, appropriate security measures must be employed to prevent divulging tactical information to enemy forces. Medical platoons should consider the following:

- Movements should be made at night, using black-out lights, daytime movement is not practical.
- Full use should be made of available defilade.
- Maximum dispersion of vehicles and personnel, in keeping security and control, should be exercised at all times.

MEDICAL SUPPLIES (CLASS VIII INCLUDING MEDICAL REPAIR PARTS) IN AIRBORNE OPERATIONS

3-292. Delivery of all supplies to the objective area is by air. Care must be taken that no critical items of medical supply are omitted, for resupply may be delayed. Losses of supplies and equipment must be anticipated; therefore, critical items must be duplicated and loaded on separate aircraft. Aircraft requirements and availability must be considered in medical supply planning for airborne operations. Follow-up supplies should be on a “push” system until firm coordination is regained with BMSO and/or MEDLOG officer assigned to the BSB SPO medical section or division surgeon section. See ATP 4-90, ATP 4-02.1, and TC 8-270.

3-293. Since HSS is provided initially by dispersed units supported by unreliable lines of communication, accompanying medical supplies are widely disseminated to Role 1 BAS and to Role 2 BSMC. During the early assault period, medical resupply to individual brigades is direct from departure airfields. When the airhead is consolidated, the brigade and/or division medical supply point resumes its normal functions. Brigade and/or division medical supply liaison personnel may remain at a departure airfield to coordinate dispatch of follow-up medical supply to the airhead.

Chapter 4

Sustainment

Sustainment is the provision of logistics, financial management, personnel services, and HSS necessary to maintain operations until successful mission completion (ADP 4-0). Sustainment for the medical platoon is a potentially challenging task due to the wide-ranging, low profile, and at times, decentralized nature of its mission. The medical platoon often operates disjoined with elements of the BAS separated from the ambulance squad and combat medic section. Distance and the need to keep sustainment tasks undetected by the threat hinder resupply operations for the medical platoon. Chapter 4 provides an overview of sustainment operations and support to the medical platoon.

Contents		
		Page
SECTION I	Basics of Sustainment	4-1
SECTION II	Sustainment Planning	4-6
SECTION III	Medical Supply Operations	4-25
SECTION IV	Maintenance	4-37
SECTION V	Disposition of Human Remains	4-47
SECTION VI	AHS Support to Detainees	4-48

SECTION I – BASICS OF SUSTAINMENT

4-1. Every member of the medical platoon participates in sustainment activities. These elements arm, fuel, fix, feed, supply, and provide transportation and personnel services for the medical platoon. Sustainment creates unique planning and operational challenges, with most of the responsibility falling to the PSG. For more information on sustainment refer to ADP 4-0 and FM 4-0.

4-2. The medical platoon leader is responsible for planning and supervising sustainment operations in the platoon. The medical PSG is the sustainment operator for the platoon. The PSG advises the platoon leader of logistical requirements during preparation for combat operations. The PSG also keeps the platoon leader informed of the platoon's status. During combat operations, the PSG coordinates directly with the HHC XO and 1SG, informing them of the medical platoon's supply, maintenance, and personnel requirements. The other medical platoon NCOs assist the PSG.

LEADER RESPONSIBILITIES

4-3. The medical platoon must plan, prepare, and execute its portion of the battalion's sustainment plan. The platoon leader develops the platoon's sustainment plan during the MDMP and refines it in the sustainment rehearsals. Rehearsals normally are conducted to ensure the smooth, continuous flow of materiel and services.

4-4. Sustainment responsibilities for the medical platoon include anticipating, reporting, and requesting support through the HHC and ensuring that they properly execute sustainment operations when support elements arrive in the platoon's location. The PSG is normally in charge of these functions with guidance and oversight provided by the platoon leader. Because the platoon leader cannot delegate responsibility, they maintain an active role in all sustainment functions.

PLATOON LEADER

4-5. The medical platoon leader is ultimately responsible for the platoon's execution of the platoon's sustainment plan. The platoon leader delegates and receives assistance from the NCOs of the platoon, but ultimately, they are responsible for the maintenance, supply, and medical plans and requisite training. Operator qualifications, maintenance, and transportation training, which all fall under sustainment is something that the platoon leader needs to address as soon as they are given the responsibilities of leading a platoon. Proper and adequate training are necessary for the platoon members to operate assigned equipment and to hold designated duties, such as vehicle recovery specialists and drivers and it is the responsibility of both the platoon leader and subordinate leaders to ensure that the unit members meet all training requirements for the positions in which they fill. The platoon leader cannot delegate responsibility so the platoon leader maintains an active role in all sustainment functions.

4-6. Maintenance is vital to the platoon, and the medical platoon leader ensures that all the platoon's assigned vehicles, weapons, personnel, and equipment such as radio's, night vision devices, optics, and medical equipment remain fully mission capable. The platoon leader tracks and manages equipment submitted for repair through all levels of maintenance. The platoon leader and platoon's NCOs are present, provide leadership, supervise, and assist maintenance operations during dedicated maintenance times. The platoon leader ensures the platoon conducts preventive maintenance on all equipment in accordance with the equipment's technical manual. The platoon leader gathers all the platoon's DA Form 5988-E (*Equipment Maintenance and Inspection Worksheet*) or DA Form 2404 (*Equipment Inspection and Maintenance Worksheet*) to track and address all deficiencies.

4-7. The medical platoon leader tracks and reports the current status of the current platoon maintenance activities. The platoon leader keeps the commander and XO informed of the medical platoon's maintenance status. The PSG is responsible for maintaining a record of all personnel with active operator's licenses that can operate platoon equipment. Sustainment is vitally important for the platoon as the medical platoon operates throughout the battalion's AO, and relies on internal supplies for sustainment.

4-8. The medical platoon leader knows the current logistic status of the platoon and quickly it consumes or expends each resource (water, fuel, ammunition, subsistence, and medical supplies). The platoon leader receives the logistics status report from the PSG, and provides it to the HHC XO or commander when necessary. The platoon leader conducts the platoon sustainment rehearsal with the assistance of the PSG.

4-9. The medical platoon leader can reach out to the BSMC commander. As the senior brigade medical service corps officer, the BSMC commander can assist in conducting medical logistics and maintenance training for the medical platoon and receive mentorship and direction.

PLATOON SERGEANT

4-10. The PSG is the medical platoon's primary sustainment planner, coordinator, and operator, and they report directly to the medical platoon leader. The PSG executes the medical platoon's logistical plan, relying heavily on the HHC and platoon SOPs. The PSG directly supervises and controls the platoon's assets. During preparations for the mission, the PSG works closely with the platoon leader, SQDLDRs, and section leaders to determine specific sustainment requirements to support the tactical plan. The PSG advises the platoon leader as they develop the sustainment requirements for paragraph 4 of the HHC OPORD and the HSS for the battalion OPORD Annex F, Appendix 3. The PSG validates the feasibility of the sustainment plan during platoon rehearsals. The PSG advises the platoon leader and assists with the conduct of the mission and planning of all aspects of each operation and assists in establishing a feasible and sustainable HSS, FHP, and MEDEVAC/CASEVAC/TACEVAC plan that includes:

- Planning
 - Coordinates with the HHC XO or supply sergeant to push resupply during combat operations.
 - Maintains the medical platoon's manning roster and crew rosters.
- Maintenance
 - Informs the medical platoon leader of the platoon's maintenance and logistics status.
 - Directs and supervises maintenance of the platoon's equipment, vehicles, weapons, and medical equipment.
 - Collects reports of the medical platoon's maintenance status in the field and sends the appropriate consolidated reports to maintenance personnel.
- Medical
 - Directs and supervises treatment and evacuation of casualties.
 - Assists in identifying and establishing the battalion CCPs during MDMP and as METT-TC requires.
 - Maintains accountability of the platoon's supplies and requirements during mission execution.
 - Gathers reports from teams, squads, and section leaders, and coordinates sustainment requirements directly with the HHC XO and 1SG.

4-11. The PSG supervises the platoon during PMCS on weapons, equipment, medical equipment, and vehicles, and shares the maintenance status with maintenance personnel, and other unit leadership. The PSG is the person with the most experience in platoon operations in regards to maintenance and is the platoon's subject matter expert on all maintenance related subjects. The PSG coordinates with the BMSO and appropriate maintenance support personnel for all medical maintenance beyond skill level one. If there is a communications equipment issue, the PSG works with battalion or brigade signal staff for repairs, if there is a medical resupply issue, the PSG contacts the BMSO. If there is an issue with ordered parts being taken off the DA Form 5988-E then they coordinate with the XO, 1SG, and maintenance personnel. The PSG has the experience and knowledge to improve the operational readiness of the platoon.

4-12. Before, during, and after missions, the PSG tracks rate of consumption of the classes of supplies for the platoon and reports those changes to the XO or 1SG. The PSG's meets the HHC LOGPAC at the designated LRP and then guides the platoon level sustainment operation. The PSG oversees and directs crews to cross-level supplies and equipment throughout the platoon and also performs these logistical functions:

- Plans for the basic load and total carrying capacity of Class I water in gallons, Class III bulk fuel in gallons, Class III (petroleum) in quarts for each critical type, Class IV fortification/barrier materials, and Class V by type of ammunition in the platoon.
- Tracks changes in consumption of Class I (subsistence), Class III (fuel), expenditure rates of Class V ammunition consumption of Class VIII medical, and Class IX repair parts; reports the logistical status to the HHC XO or 1SG.
- Rehearses (to include under CBRN conditions) and directs the battalion's medical treatment and evacuation. Casualty evacuation is the maneuver leadership's responsibility but the medical platoon can assist in planning and synchronizing CASEVAC with MEDEVAC.
- Monitors actions during resupply operations and ensures each squad or section leader understands actions at the resupply point.
- Collects reports of the platoon's maintenance status in the field and sends the appropriate consolidated reports to maintenance personnel.
- Ensures that repair parts are used or properly stored.
- Ensures vehicles readiness.
- Ensures the medical platoon executes HHC sustainment operations according to the sustainment plan.
- Assists the platoon leader in executing the platoon-level sustainment rehearsal with squad and section leadership present.
- Monitors actions on-site, guides platoon level sustainment operations, and ensure each vehicle commander is tracking actions at the resupply point where the PSG meets the LOGPAC at the designated LRP.
- Cross-levels supplies and equipment throughout the platoon.

SQUAD AND SECTION LEADERS

4-13. Medical squad and section leaders are responsible for supporting the PSG in executing the sustainment plan and overseeing that all members of their squad or section understand the medical platoon's sustainment plan. Squad and section leaders provide the direct guidance and supervision down to the lowest level and play an integral Role in all assigned tasks.

4-14. Squad and section leaders provide the required oversight needed when operators are conducting PMCS, and ensure that dispatch records are accurate and turned in on time. For sustainment, squad and section leaders compile personnel and logistic reports from the squad or section and submit them to the PSG. Squad and section leaders make sure everything is accurate and turned in according to the platoon tactical SOP. The squad or section leaders obtain supplies, equipment, and mail from the PSG and ensure proper distribution within the squad and section. They transfer and cross-level equipment and supplies when required and provide direct guidance during platoon resupply operations. Additionally, squad and section leaders correct hygiene deficiencies and monitor the health and welfare of the members of their squad and section.

4-15. Combat medics submit resupply request to the senior line medic who pushes to the BAS or utilizes the companies supply channels.

SUSTAINMENT FUNCTIONS

4-16. Sustainment involves the interrelated functions of conducting logistics, providing personnel services, providing financial management, and providing HSS (see table 4-1). Logistics determines the depth and duration of unit operations and is essential to retaining and exploiting the initiative.

Table 4-1. Sustainment functions

<i>Sustainment Functions</i>			
<i>Logistic services</i>	<i>Financial services</i>	<i>Personnel services</i>	<i>Health service support</i>
<ul style="list-style-type: none"> • Maintenance. • Transportation. • Supply. • Field services. • Distribution. • Operational contract support. • General engineering support. 	<ul style="list-style-type: none"> • Finance operations. • Resource management. 	<ul style="list-style-type: none"> • Human resources support. • Legal support. • Religious support. • Army band operations. 	<ul style="list-style-type: none"> • Casualty care, including <ul style="list-style-type: none"> - Medical treatment (Organic and area medical support). - Treatment of chemical, biological, radiological and nuclear patients. • Hospitalization. • Medical evacuation (including medical regulating). • Medical logistics (including blood management).

CLASSES OF SUPPLY

4-17. There are ten classes of supply. Each class has a major impact on the medical platoon's ability to accomplish its mission. The PSG obtains supplies and delivers them to the medical platoon based upon the established priorities for delivery set by the platoon leader. Combat offensive operations demand Class I, III, V, and IX supplies and equipment take priority because they are the most critical. Defensive operations also increase the rate of Class IV and lessen the rate of Class VIII. To accomplish its primary mission of treating and evacuating the battalion's wounded the medical platoon must add Class VIII to this list (see table 4-2 for the classes of supply). For more information on Army MEDLOG and Class VIII refer to ATP 4-02.1. See TC-8-270 for the structure and operation of the BSMO assigned to the Role 2 BSMC.

Table 4-2. Classes of supply

Class I	Subsistence, including health and welfare items.
Class II	Clothing, individual equipment, tentage, tool sets and tool kits, hand tools, administrative, and housekeeping supplies and equipment (including maps). This includes items of equipment, other than major items, prescribed in authorization/allowance tables and items of supply (not including repair parts).
Class III	Petroleum, oils, and lubricants: petroleum and solid fuels, including bulk and packaged fuels, lubricating oils and lubricants, petroleum specialty products; solid fuels, coal, and related products.
Class IV	Construction materials, including installed equipment and all fortification/barrier materials.
Class V	Ammunition of all types (including chemical, radiological, and special weapons), bombs, explosives, mines, fuses, detonators, pyrotechnics, missiles, rockets, propellants, and other associated items.
Class VI	Personal-demand items, which include candy, soaps, and cameras.
Class VII	Major end items; a final combination of end products which is ready for its intended use: (principal item) for example, launchers, tanks, mobile machine ships, and vehicles.
Class VIII	Medical materiel, including medical-peculiar repair parts.
Class IX	Repair parts and components, including kits, assemblies, and subassemblies, reparable and non-reparable, required for maintenance support of all equipment.
Class X	Material to support nonmilitary programs, such as agricultural and economic development, not included in Classes I through IX.

SECTION II – SUSTAINMENT PLANNING

4-18. The medical platoon leader fully integrates sustainment planning into all operational planning. The HHC SOP should be the basis for sustainment operations, with planning conducted to determine specific requirements and to prepare for contingencies. The medical platoon leadership should address deviations from the

sustainment SOP early in the planning process. In some situations, sustainment planning begins before receipt of the mission as part of the ongoing process of refining the sustainment plan.

SUSTAINMENT PLANNING FACTORS

4-19. Planning for sustainment is primarily a HHC and battalion-level task. While the company commander, XO, and ISG plan the task, the medical platoon leader and PSG are responsible for the execution of the plan. Concurrent with higher level planning, the medical platoon must plan, prepare, and execute its portion of the sustainment plan. The platoon leadership develops and refines their sustainment plan during TLP process.

4-20. Maneuver battalion medical platoons coordinate directly with the battalion logistics staff, HHC commander, and forward support company. Battalion staffs tend to have a hands on approach in the battalion's medical plan. They anticipate and coordinate directly with the medical platoon leader and PSG.

4-21. The medical platoon leader develops the sustainment plan by verifying exactly what they have on hand to accurately estimate their support requirements. This is an implied task for the HHC XO and ISG. This process confirms the validity and feasibility of the medical platoon's sustainment plan. The platoon leader submits changes to the medical platoon's sustainment plan to the HHC XO and battalion logistics staff.

4-22. The sustainment plan provides answers to the operational questions that are identified during platoon mission analysis. Leaders should develop questions in relation to mission requirements, the threat, terrain and weather, time and location, and other considerations. The sustainment plan should provide answers to operational questions such as the following:

- Types of support. Based on the nature of the operation and specific tactical factors, what types of support will the medical platoon need?
- Quantities. In what quantities will this support be required?
 - Will emergency resupply (Classes I, III, V, or VIII) be required during the battle?
 - Does this operation require prestocked supplies?
- Threat. What are the composition, disposition, and capabilities of the expected enemy threat? How will these affect sustainment plan during execution?
 - Where and when will the expected contact occur?
 - What are the platoon's and battalion's expected casualties and vehicle losses based on the nature and location of expected contact?
 - What impact will the enemy's special weapons capabilities (such as CBRN) have on the battle and on expected sustainment requirements?
 - Are health threats present in the OE, and have mitigation strategies been identified?
 - How many detainees are expected, and where?

- Terrain and weather. How will terrain and weather affect sustainment plan during the battle?
 - What ground will provide the best security for maintenance and CCPs?
 - What are the platoon's vehicle and CASEVAC routes?
 - What are the company's dirty routes for evacuating contaminated personnel, vehicles, and equipment?
- Time and location. When and where will the platoon need sustainment?
 - Based on the nature and location of expected contact, what are the best sites for the CCP?
 - Where will the detainee collection points be located?
- Requirements. What are the support requirements, by element and type of support?
 - Which section has priority for emergency Class I resupply?
 - Which section has priority for emergency Class III resupply?
 - Which section or squad has priority for emergency Class V resupply?
 - Which section has priority for emergency Class VIII resupply?
- Risk. Will lulls in the battle permit support elements to conduct resupply and MEDEVAC/CASEVAC operations in relative safety?
- Resupply techniques. Based on information developed during the sustainment planning process, which resupply technique should the platoon use?

MISSION REQUIREMENTS

4-23. When conducting sustainment planning, the platoon leader and subordinate leaders need to address mission requirements. Medical requirements may vary, so leaders address additional classes of supply they require outside of the basic load. Platoon leadership should forecast their status on the classes of supply and figure out if an emergency resupply of Class III and V may be necessary during the mission. While planning for mission requirements, the platoon leadership identifies locations to possibly place pre-stocked supplies. The platoon analyzes attachments, such as medical/evacuation elements from the Role 2 BSMC or an FRSD and their requirements, and whether they may need additional supplies for the attachments. Finally, the platoon will have to determine if the developed sustainment plan is nested with and will support the tactical plan. Adequate tracking and especially reporting to higher headquarters is essential in staff planning and forecasting.

THREAT

4-24. While conducting sustainment planning, the platoon leader determines the current enemy situation and future enemy activity, enemy capabilities, and how threat contact affects resupply during the mission. The platoon leader determines expected enemy contact, and assists in the planning and support of CASEVAC/MEDEVAC and sustainment that addresses the enemy (see chapter 1 and chapter 4).

TERRAIN AND WEATHER

4-25. Terrain and weather can have a significant impact on sustainment planning for the medical platoon. When conducting sustainment planning the platoon leader assesses the terrain to determine locations that provide the best security and feasibility for the trains, maintenance and CCPs. The platoon leader identifies MEDEVAC routes and routes for the evacuation of contaminated patients and equipment. Platoon leaders consider weather effects on operations during sustainment planning. Weather may increase or decrease sustainment requirements. For example, heat will increase water consumption, but cold can increase calorie intake.

TIME AND LOCATION

4-26. When conducting sustainment planning, one important factor of the plan is time and location. The platoon leadership determines when and where resupply will be required. They have to ensure that their methods and techniques nest with the battalion resupply plans. Leadership estimates to determine if their vehicles and personnel have the required resources available to accomplish the mission, and receive sustainment at the dates prescribed. The platoon leadership addresses resupply of mounted and dismounted medical assets, using the best techniques.

OTHER PLANNING CONSIDERATIONS

4-27. During protection planning, the platoon needs to develop a plan for detainees. Detainee planning is later in this chapter (see section VI), but the platoon needs to know how to support the battalion medically in regards to detainees.

PRIORITY OF SUPPORT

4-28. Sometimes the medical platoon leadership designates what unit has priority to receive sustainment. One supported maneuver company may require a higher medical support priority over others. This will be determined by which element is the main effort during actions on the objective, but a second main effort or a unit in reserve that may have a critical follow on mission can be designated as the priority as well.

FORECASTING LOGISTICS

4-29. Accurately forecasting logistic requirements for the medical platoon is crucial to the success or failure of a mission. Medics operating in a hot and humid environment need extra water. Vehicles that operate in a dry desert climate, for instance, will burn through oils and other Class III products. Weapons need cleaning and maintaining at an increased rate.

4-30. Forecasting required logistic items is a simple task, as long as the platoon leadership remains active, and aware of historical platoon usage, and needs. While performing mission analysis the platoon leadership consider what supplies they have on hand, what are they going to be doing, and what supplies are needed. Leaders then have to go out and acquire the resources. The following classes of supply highlights only the most common for the medical platoon.

CLASS I (SUBSISTENCE)

4-31. Class I is one of the most important supplies in regards to sustainment planning for a medical platoon. The medical platoon should forecast Class I based on the amount of medical platoon personnel and attachments operating within the medical platoon. Meals and water consumption will provide the medical platoon the nutrients and hydration needed while conducting AHS support operations.

4-32. Plan meals while understanding the unit feeding cycle. Individual operational rations are available to the medical platoon when there are no heat and serve meal options available. Water is a resource that all leaders carefully watch and maintain in abundance, during all missions. Mission requirements and environmental factors always alter water consumption within a platoon. Table 4-3 and table 4-4 are estimates for Class I (water consumption) that the medical platoon can use to provide forecasting assistance in planning AHS support for the battalion.

Table 4-3. Requirements for universal unit level gallons per person per day

<i>Function</i>		<i>Tropical</i>		<i>Arid</i>		<i>Temperate</i>		<i>Cold</i>	
		<i>STNG</i>	<i>MIN</i>	<i>STNG</i>	<i>MIN</i>	<i>STNG</i>	<i>MIN</i>	<i>STNG</i>	<i>MIN</i>
Drinking		3.30	3.30	3.30	3.30	1.65	1.65	2.20	2.20
Personal hygiene	Brushing teeth 3 times/day	0.22	NA	0.22	NA	0.22	NA	0.22	NA
	Brushing teeth 1 times/day	NA	0.08	NA	0.08	NA	0.08	NA	0.08
	Shaving	0.23	0.23	0.23	0.23	0.23	0.23	0.23	0.23
	Washing hands 6 times/day	0.83	NA	0.83	NA	0.83	NA	0.83	NA
	Washing hands 3 Times/day	NA	0.42	NA	0.42	NA	0.42	NA	0.42
	Sponge Bath 5 times/week	0.40	0.40	0.40	0.40	0.40	0.40	0.40	0.40
Food preparation	Individual operational meal	0.43	0.14	0.43	0.14	0.43	0.14	0.43	0.14
	UGR – A of H&S	1.78	NA	1.78	NA	1.78	NA	1.78	NA
Heat injury treatment		0.01	0.01	0.01	0.01	0.01	0.01	0.01	0.01
Vehicle maintenance		0.36	0.36	0.36	0.36	0.19	0.19	0.19	0.19
Non-potable water total		0.36	0.36	NA	NA	0.19	0.19	0.19	0.19
Potable water total		7.2	4.58	7.2	4.58	5.55	2.93	6.1	3.48
Gallons per day per Soldier total		7.92	5.3	7.92	5.3	5.93	3.31	6.48	3.86
Legend:									
A a-ration		NA not applicable							
H&S heat and serve		STNG sustaining							
MIN minimum		UGR unitized group ration							

Table 4-4. Daily environmental water consumption chart in gallons per person

<i>Use</i>	<i>Temperature</i>	<i>Tropical</i>	<i>Arid</i>	<i>Arctic</i>
Drinking water	1.5	3.0	3.0	2.0
Personal hygiene	1.7	1.7	1.7	1.7
Field feeding	2.8	2.8	2.8	2.8
Heat injury treatment	0.1	0.2	0.2	0.1
Vehicle maintenance			0.2	
Standard planning factor	6.1	7.7	7.9	6.6

CLASS III (PETROLEUM, OILS, AND LUBRICANTS)

4-33. The medical platoon relies heavily on their vehicle platforms to retain freedom of maneuver in order to medically support the maneuver battalion through treatment and evacuation. Although vehicles are great to use, they require substantial amounts of Class III to operate. Medical platoon leaders have the added responsibility to plan and forecast required Class III to meet their objectives. Table 4-5 can assist the medical platoon leadership in understanding their vehicles burn rates in order to calculate the Class III requirements when planning sustainment operations during the mission.

Table 4-5. Medical platoon vehicle burn rates

<i>Vehicle</i>	<i>Fuel capacity (gallons)</i>	<i>Idle (gal/hr)</i>	<i>Cross country (gal/hr)</i>	<i>Road primary/secondary (gal/hr)</i>
AMPV	1.5	3.0	3.0	2.0
STRYKER	1.7	1.7	1.7	1.7
HMMWV	2.8	2.8	2.8	2.8
LMTV	0.1	0.2	0.2	0.1
Legend:				
AMPV	armored multi-purpose vehicle			
Gal	gallon			
HMMWV	high mobility multipurpose wheeled vehicle			
Hr	hour			
LMTV	light medium tactical vehicle			

4-34. Although table 4-6 on page 4-12 is only an estimate that assists in planning, the medical platoon can use an equation to figure out their fuel consumption prior the start of a mission. If a medical platoon leader is operating six M1113 Stryker MEDEVAC vehicles for evacuating patients followed by a movement, they would use the following formula to calculate for a 24-hour period.

Table 4-6. Medical platoon vehicle burn rate equation

Medical Platoon Vehicle Burn Equation	
MEDEVAC followed by battalion movement (24 hr period)	
MEDEVAC (8 hrs): $6 \text{ M1113} \times 7.66 \text{ (cross country)} \times 8 \text{ (hrs)} = 367.68 \text{ gals}$	
Movement (16hrs): $6 \text{ M1113} \times 4.60 \text{ (Secondary roads)} \times 16 \text{ (hrs)} = 441.60 \text{ gals}$	
24hr period = $367.68 + 441.60 = 809.28 \text{ gals of fuel (estimated to be used)}$	
Each vehicle will use $809.28 / 6 \text{ M1113} = 134.88 \text{ gals per vehicle}$	
The M1113 has a fuel capacity of 56 gallons.	
This equation results in three COAs:	
1. If the platoon carries an additional 80 gals of fuel per vehicle, they could go 24 hrs without a Class III resupply.	
2. If the platoon carries an additional 15 gals of fuel per vehicle they would require one (1) Class III resupply.	
3. If the platoon carries no additional fuel per vehicle, it would require two (2) Class III resupplies.	
Legend:	
COA	course of action
hr	hour
gal	gallons
hrs	hours

CLASS V (AMMUNITION)

4-35. The medical platoon receives their Class V from the battalion and requests additional Class V throughout the mission. There is no one size fits all unit basic load issued for combat operations. Each mission receives a unit basic load determined by battalion and brigade planners, and requested through the Total Ammunition Management Information System, which is approved by the logistics staff.

CLASS VIII (MEDICAL)

4-36. The maneuver battalion medical platoons/sections of a BCT operating Role 1 BAS request their Class VIII supplies from the BMSO via the approved Theater Enterprise Wide Logistics System (TEWLS). The medical platoons/sections have limited capability for internal MEDLOG management; they are primarily customers of the BMSO. Class VIII requests are filled out electronically in DCAMS or DA Form 3161 (*Request for Issue or Turn-in*) (see unit TACSOP). If unable to fill a high priority request, the BMSO sends it to the MLC or next higher MEDLOG supply support activity (SSA) that can fill it. Emergency requisitions of Class VIII supplies for the BCT are completed per the theater and unit TACSOP. The BASs are responsible for managing Class VIII supplies in their battalions down to the individual Soldier level, in the form of the individual first aid kit and Common Table of Allowances 8-100 authorizations.

4-37. The medical PSG is the key to sustaining medical support through the timely and accurate Class VIII supply/resupply of the medical elements of the maneuver battalion. The PSG must understand what assets the platoon has available and determine what the organization will need for future operations and for all elements of the medical platoon above the baseline MES, and they coordinate for the push/pull of medical resupply sets.

4-38. Accurate Class VIII asset inventory is the essential baseline to ensure the medical platoon's ability to function in any given scenario. From that baseline, Class VIII resupply estimates are established for current and future operations. Class VIII materiel is packed and configured for distribution to the requesting unit through available distribution channels. The primary method of Class VIII resupply is to backhaul ambulance returning to the Role 1 BAS within the brigade's AO. The alternate method is utilizing LOGPACs.

4-39. The medical platoons/sections of the Role 1 BAS operations request their Class VIII supplies from the BMSO established by the Role 2 BSMC. The medical platoons have limited capacity and capability for internal MEDLOG management and are primarily customers of the BMSO. Routine requisitions are sent by the Role 1 BAS via DCAM over the MC4 system. Emergency requisitions of Class VIII supplies for the BCT are completed according to the unit tactical SOPs.

4-40. Medical platoons request medical chemical defense materiel to the BMSO through the logistics staff. Refer to Supply Bulletin (SB) 8-75-S7.

Class VIII Supply Procedures in a Deployed Setting

4-41. In the field, the medical platoon maintains a three-day (72-hour) stockage of Class VIII supplies within its MES. Several national stock numbers (NSNs) may be associated with a line item number (LIN). To ease searches this publication will use LINs. The following MES are authorized for the IBCT medical platoon:

- Chemical Agent Patient Protective Wrap, LIN M23673 (1).
- Patient Decontamination and Chemical Treatment, LIN M25865 (1).
- Tactical Combat Medical Care, LIN M30499 *(2).
- Ground Ambulance, LIN M26413 (8).
- Combat Medic, LIN 6545-01-228-1886 (23).

Note. * Indicates that one (1) of each MES will accompany a treatment team when the medical treatment squad is conducting split-based operations. Other types of medical platoons should check their TOE for authorized MESs.

Authorized Stockage and Controls

4-42. Medical supply items authorized for use by the medical platoon are normally those items that are identified as part of the MES. Items that are not in the MES must be approved for stockage by the division surgeon. This includes both expendable items and pharmaceuticals. For perishable and dated items that are found in the MES, a DA Form 4998-R (*Quality Control and Surveillance Record for TOE Medical Assemblage*), is initiated for all expendable and durable items in the medical assemblage. For a medical item, that has a shelf life and demands are expected, a DA Form 4996-R, (*Quality Control Card*) will be prepared and maintained in accordance with SB 8-75-11. These items are referred to as potency and dated items. Controlled pharmaceutical such as R and Q items (see note below) are stored in a secured container. A record of

controlled medical items will be kept on DA Form 3862 (*Controlled Substances Stock Record*).

Note. Controlled substances are drugs so designated by the Drug Enforcement Administration. A list of these drugs and changes are published in the Federal Register and in the SB 8-75 series. Note R and Q identify standard controlled substances in the notes column of the Federal Supply Catalog, DOD Section, Medical Materiel and by controlled inventory items codes R and Q in the Army Master Data File.

Class VIII Requisitioning Procedures in a Deployed Environment

4-43. In a deployed setting, the BAS requisitions its medical supplies from the BMSO. A TTP is for the BMSO to collocate with the distribution company SSA to leverage currently established lines of communication. For an example of a MEDLOG distribution overlay (see figure 4-1).

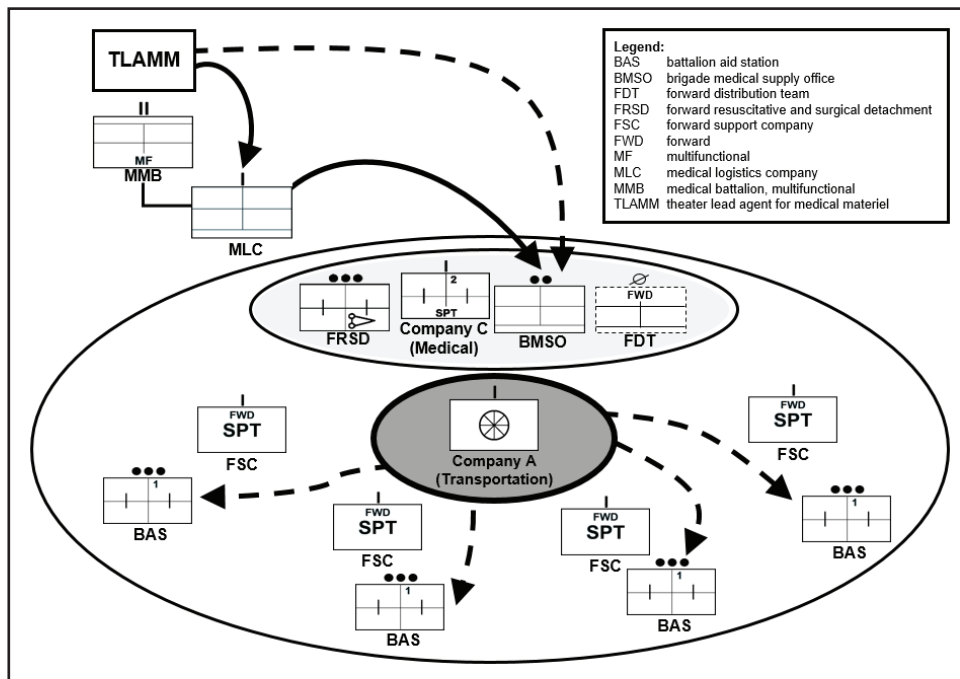

Figure 4-1. Medical logistics distribution overlay

4-44. Routine requisitions for Class VIII supplies are submitted to the BSMC using a DA Form 3161 (*Request for Issue or Turn-in*), for each item in accordance with Department of the Army Pamphlet (DA Pam) 710-2-1. The BSMC may fill these requests from its MESSs or forward them to the BMSO. The BMSO will fill the requests and send items forward to the supporting BSMC via ambulance backhaul (Primary) and LOGPAC (Alternate). The BSMC coordinates the delivery of Class VIII supplies to the

requesting unit through the BSB SPO medical section. Requisitions may also be sent via radio. Prior to deployment, individuals should know the Class VIII resupply requirement and procedures.

4-45. Emergency requisitions for Class VIII supplies are sent to the BSMC via radio or telephone. Any item not filled is immediately forwarded to the BMSO. Delivery of emergency requests will be by the most expedient mode of transportation, based on METT-TC factors. Normally, a requisition with a 03 or higher priority will require the approval of the commander.

Class VIII Supply Procedures at Home Station

4-46. When not in a deployed environment, the BMSO resupplies the medical platoon using supply point distribution. The BMSO usually works out of a warehouse or supply room for conducting medical logistics operations. Supported units should be provided a layout (see figure 4-2 for an example of a BMSO layout) that shows key locations in the office.

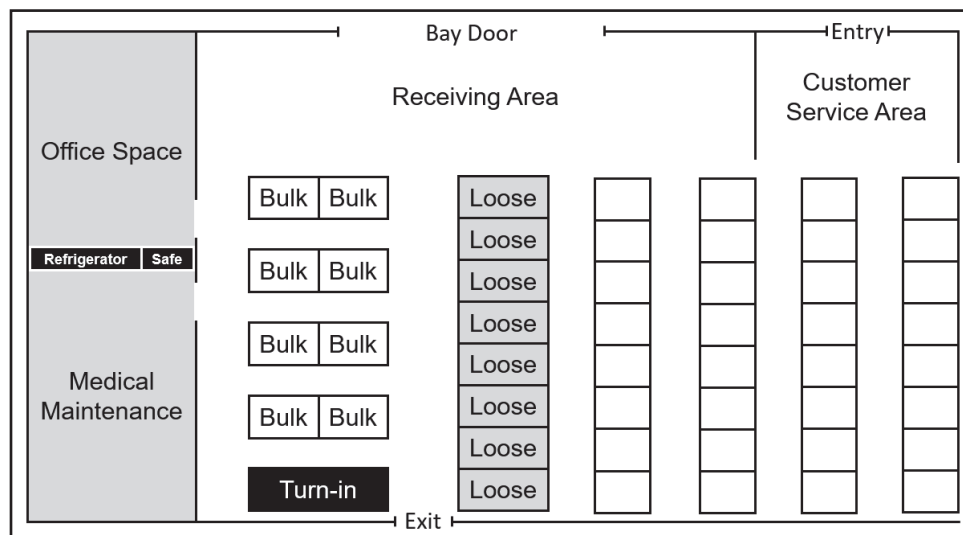

Figure 4-2. Example, brigade medical supply warehouse layout

4-47. Operations of the Role 1 BAS at home station are normally under the control of the installation MTF commander. For Role 1 BAS (home station) operations, Class VIII items may be requisitioned directly from the installation MTF. Under other situations, the BAS orders from the BMSO or supporting MMB MLC. The installation medical supply activity is operated by either the installation MTF or MMB.

4-48. The installation MTF commander establishes requirements for Role 1 BAS operations in garrison. A list of Class VIII items required and authorized at the BAS is identified by hospital SOP or regulation. Medications are identified in the hospital formulary. When operating a Role 1 BAS in a garrison environment, medical platoons are subject to the same standard of care wherever they operate.

4-49. Requisitioning information includes:

- Department of Defense activity address code. Example: YNAMTF
- Serial numbers. The document register maintainer issues the serial number, and this number is preceded by the Julian date on each request for issue or turn-in. Serial number example: W35MW2.
- Account processing code. This code is issued by the supporting MEDLOG element and identifies the unit. Example: AWHA.
- A DA Form 1687 (*Notice of Delegation of Authority – Receipt of Supplies*) will be on file with the installation MTF and a copy maintained by the PSG or their designated person for supply actions.
- The PSG or their designated person for supply activities maintains the document register.

4-50. A supply matrix will be posted in the supply 3-ring binder with the following information:

- Quantity maintained.
- Quantity needed to be ordered.
- Date medication was ordered.
- Expiration dates of pharmaceuticals (checked each month).

4-51. Expired medications issued from the installation MTF are turned in to the installation MTF. Expired medications issued from the TOE MES are turned in to the BMSO.

4-52. When multidose vials are opened, they are dated and initialed by the user.

4-53. The medication refrigerator should be cleaned and defrosted monthly.

4-54. Medication lockers are unlocked during sick call but are locked if the provider leaves the room. The safe with code R and Q items is secured except for removal of medication to fill a prescription. The field surgeon, PA, or PSG will maintain keys. Only the field surgeon, PA, or PSG will have the combination to the safe.

4-55. A 100 percent inventory of all assets belonging to the medical platoon is performed on an annual basis according to DA Pam 710-2-1 and DA Pam 710-2-2.

DEFENSE MEDICAL LOGISTICS STANDARD SUPPORT DEFENSE CUSTOMER ASSISTANCE MODULE LEVEL 1

4-56. Users and administrators can receive the DCAM field guides and user manuals from the Joint Medical Logistics Functional Development Center. To establish a DCAM Level 1 account, download the DCAM application from the Army Medicine Portal. When using this DCAM page link, select the appropriate CAC email certificate.

Note. If using an MC4 imaged laptop, the DCAM application and user manuals will already be installed on the laptop.

4-57. After DCAM is installed, establish an administrator profile to manage DCAM and any additional users.

4-58. Section 2, Getting Started, of the DCAM User Manual depicts and discusses how to get started in DCAM. It discusses configuring the environment, creating users and setting up connections for sending and receiving orders. It also walks users through the steps for creating and sending orders.

- Configuring the environment. Enter the unit's information on the Add/Update Environment screen. This includes:
 - DOD Activity Address Code.
 - Unit description.
 - Yearly budget.
 - Serial number range.
 - Fund codes/account processing codes.
 - Supplementary addresses.
- Set up DCAM communication service (DCS). Consult the System Administrator Guide to set up DCS configuration prior to continuing the "Getting Started" section. Different actions are required based on your connectivity to a DCAM Level II system versus Defense Medical Logistics Standard Support.
- Set up network accounts. This section describes how to establish the DCAM to DCAM or Global Combat Support System-Army (GCSS-A) connection via hypertext transfer protocol secure (https). Your supply activity will provide most of the information required to complete this section.
- Set up users. The BMSO DCAM administrator assigns and manages individual user logins and passwords.
- Set up picture location. The digital catalog is a disc containing pictures of items the supplier stocks or can obtain. If you have the digital catalog and wish to use it in DCAM, refer to Picture Location in the DCAM User Manual.
- Download a supplier catalog. To download a supplier catalog, click the Transfers icon; the Network Transfer Manager screen will appear. At this screen, highlight the Host Account you configured for the supplier and click connect. Click Get Supplier Files and watch for a yellow triangle to appear on the status bar at the bottom of the DCAM window. The triangle indicates that you have downloaded supplier files that are ready to be imported into DCAM. Click Close to exit the Network Transfer Manager; then double-click on the yellow triangle to Process Incoming Files. Hold the Shift key down and click on the last file listed to select all files, click Process. After all files are completed successfully, click Close. This returns you to the Process Incoming Files screen. You may choose to remove the downloaded files, now that they have been imported into DCAM, by clicking Delete. Click Close. It is extremely important to maintain the most updated supplier catalog. The supplier catalog should be downloaded daily.

TACTICAL CONNECTIVITY

4-59. The BMSO's tactical connectivity between DCAM and its supported TEWLS or Defense Medical Logistics Standard Support supply activity is dependent on non-secure internet protocol router availability. Coordination must be made with the Sustainment Automated Support Management Office for access to the combat service support very small aperture terminal network and satellite connectivity.

4-60. Defense medical logistics standard support's customer assistance module allows the medical platoon to perform functions off-line and exchange files with the supporting SSA when non-secure internet protocol router communications are available. This exchange includes the download of selected catalog files from the SSA's DCAM or GCSS-A application. This makes it possible for customers to research the catalog for prime and substitute items. When non-secure internet protocol router capability is not available, customer files can be exported to compact disc or printed for delivery to the supporting SSA. Although DCAM connectivity may not be available, users may still have access to email in which they can send order files. When experiencing latency issues with the combat service support very small aperture terminal, the user can break-up the demands on the system by setting times for transmitting and downloading data.

MEDICAL PUSH-PACKAGES

4-61. Push-packages are a predetermined amount of supplies designed and managed by the BMSO in coordination with the supporting SSA. Ideally, these packages are coordinated by the BMSO prior to deployment. They are issued during early-entry operations on a scheduled basis or upon request. The BMSO develops them to support Combat Training Center rotations as a training platform. Medical resupply sets and preconfigured push-packages are the primary means of resupply in the BCT prior to establishing line item requisitioning. Push-packages are also used to simplify large orders or prepare a unit for a specific mission for which they will need immediate resupply at a moment's notice. One of the more common push-packages that units build is MASCAL sets. They place them at CCPs on their forward operating base in a deployed setting. The BMSO builds and stores these push-packages for their BCT. They release them on an as needed basis or predetermined condition/amount of time. Two common push-packages are unit and mission configured loads. The unit develops unit-configured loads to facilitate ordering of common items that are often used together. This might be a CLS bag push-package containing all items for 10 CLS bags. The mission configured loads are developed specifically for a named operation or mission where resupply cannot be conducted through line item requisitioning because large quantities of items will be needed for immediate delivery. Regardless if it is a mission configured load or unit configured load being developed, the BMSO follows the same process. This process is very similar to the authorized stockage list review board, but has more stakeholders involved. The BMSO should ensure the medical platoon has the ability to store pre-positioned packages as LSCO may require constant movement with limited Class VIII storage.

4-62. Key personnel involved in the push-package working group and development process include:

- Brigade surgeon.
- Brigade support medical company commander.
- Brigade support battalion's support operations MEDLOG officer.
- Medical platoon leaders from each battalion.
- S3 representative (to provide mission specific information).

4-63. Once the group is established is must define the operation. The operations staff representative provides information on the OE and the situation/mission for which the group is planning. This assists in identifying area and mission unique considerations that affect the development of push-packages. In the event that the medical platoon is replacing another unit, the operations staff can provide contact information. Contacting the outgoing unit gives more finite information on the environment, what push-packages they used and the availability of Class VIII in theater.

4-64. In addition to providing the unit's most commonly used items, the members of the push-package working group can provide the standard rate of consumption of Class VIII items. This helps to determine the amount of an item in a push-package and how often the BMSO should schedule delivery.

4-65. Once the group has determined what push-packages will be needed, what they will contain, and how often that they will be needed, the BMSO and SPO MEDLOG officer determine what delivery method they will utilize. Common methods of delivery are the ambulance backhaul system (primary method), the BSB tactical convoy delivery (alternate method), and aerial resupply (METT-TC). The operational area and the urgency of the request will dictate the methods available and how the BMSO ships the push-package.

4-66. The United States Army Medical Materiel Agency (USAMMA) website has several automated tools that provide unit assemblage (UA), catalog search capability, functional descriptions, and detailed component listing reports. These component listings provide Roles 1 through 3 UA reports. To research a particular set, the UA database provides listings for multiple years under the same line item number. To research specific medical devices, the Medical Materiel Information Portal (MMIP) has replaced the functionality of the Medical Services Information Logistics System and Unit Assemblage web applications. All data and search capability from those applications is now found in the MMIP as catalog search and unit assemblage search. The MMIP also provides a library of USAMMA and United States Army Medical Materiel Development Activity publications including medical equipment literature, UA handbooks, and equipment start-ups. The UA Search feature provides a database that cross-references key UA component materiel data. For additional information, access the USAMMA website.

4-67. The Defense Health Agency Medical Logistics Division under the Business Support Directorate offers multiple tools that assist in planning for operations. Among these are the Joint Deployment Formulary and Medical Contingency Requirements Workflow (MCRW). The MCRW is a web-based, enterprise-wide clinical/medical logistical data repository for—

- Medical materiel and personnel planners.

- Medical combat and requirements developers.
- Clinicians and trainers.
- Medical logisticians and force structure planners.

4-68. The MCRW provides a data set of clinical and MEDLOG data. The Joint Deployment Formulary and the MCRW are used by various Joint and Service-level applications to predict materiel and personnel requirements. The MCRW can be accessed through the Defense Logistics Agency website and used to assist BMSOs and SPO MEDLOG officers in developing a package.

4-69. The Medical Product Data Bank is an authoritative, accurate and synchronized source of product information. It serves as a “data backbone” for the BMSO. The Medical Product Data Bank is a powerful research tool that can assist in developing push-packages and provide units item identification numbers for theater stocks.

Note. The MCRW and Medical Product Data Bank applications can be found at the Defense Logistics Agency website.

BASIC AND COMBAT LOADS

4-70. Prior to any mission, medical platoon members ensure they have all appropriate supplies. The medical platoon accomplishes these tasks at the lowest level and is verified by PSG and platoon leader during PCIs. Throughout the mission, the PSG ensures basic loads are replenished. (See ATP 4-02.1, ATP 4-35, ATP 4-43, and ATP 4-44 for more information).

4-71. The basic load is the quantity of supplies required on hand and which a unit or formation can move. It is expressed according to the wartime organization of the unit or formation and maintained at the prescribed levels.

4-72. The combat load is the minimum mission-essential equipment and supplies, as determined by the platoon leader responsible for carrying out the mission, required for medics to fight, treat, and evacuate casualties and to survive immediate combat operations. The platoon leaders should base the medical platoon’s combat load on mission requirements.

LOAD PLANNING CONSIDERATIONS

4-73. Vehicle load plans should be standardized for every vehicle type in the platoon. Not every vehicle is going to have the same equipment, but each vehicle load plan needs to match or be as similar to each other as possible. Standardized load plans are done so in the event of an emergency all crewmembers will know where all the platoon equipment is stored and located in each vehicle. At a long halt, tailgate medicine support may need to be performed. If platoon members need to secure medical chests and/or equipment out of a vehicle, they should be able to run to any vehicle to grab the equipment and know its location. The medical platoon should pack items in reverse order of use. The most essential items should be the last thing loaded. Standardized load plans are put into platoon tactical SOPs, and verified during PCC and PCI.

4-74. Preparing a military vehicle for combat operations is one of the most tedious, tiresome, and laboring tasks for the medical platoon. Each piece of vehicle and platoon equipment has to be stored appropriately. Ammunition and medical supplies need to be placed within reach of vehicle crewmembers and medical platoon personnel, maintenance equipment and tools have to be available for the driver, recovery equipment will be required during missions, and all this equipment will have to be readily available. Water and fuel cans are placed outside of the vehicle but are separated from each other. Medical equipment and supplies will have to be stored in an accessible location. These are all examples of why load-planning considerations are so important for medical treatment and evacuation mission preparation.

SUSTAINMENT OVERLAY

4-75. After the brigade commander selects a COA, the staff communicates this decision through an OPLAN/OPORD. The SPO, with input from the other BSB logistic staff elements (personnel staff, battalion and brigade surgeons, BSMC commander, and the BMSO) prepares the brigade concept of sustainment, paragraph four in the OPORD (see figure 4-3 on page 4-22 for an example of a sustainment overlay). At the maneuver battalion level, the key to understanding the medical platoon's sustainment plan should be the development and distribution of the sustainment overlay. The sustainment overlay should include current and proposed train's locations with LRPs, CCP including the marking methods, maintenance control points (MCP), HLZs, AXP, and any friendly sustainment locations such as forward operating bases or combat outposts. See FM 1-02.2 for control measures necessary for the overlay. When developing paragraph 4 of the OPORD, the platoon leader should include the following areas (this list is not all inclusive):

- Orientation. Orient all medical platoon personnel to the sustainment overlay.
- Supply. Include all LRPs. List specifics of who is carrying what by class of supply. For example, each Soldier will have a three-day supply of Class I and the medical platoon will maintain a three-day supply of Class VIII.
- Transportation. What is the current transportation plan, order of march with timeline to line up and be ready condition 1 (known as REDCON), bump plans, and recovery assets/plan?
- Maintenance. Include all equipment, MCPs, and procedures such as utilizing and exchange of the DA Form 5988-E and DA Form 2404.
- Personnel services. Include who is responsible for detainee processing and locations for detainee collection areas. This includes medical care.
- Army Health System support. Include locations of established treatment facilities, operational public health, evacuation procedures, and responsibilities.

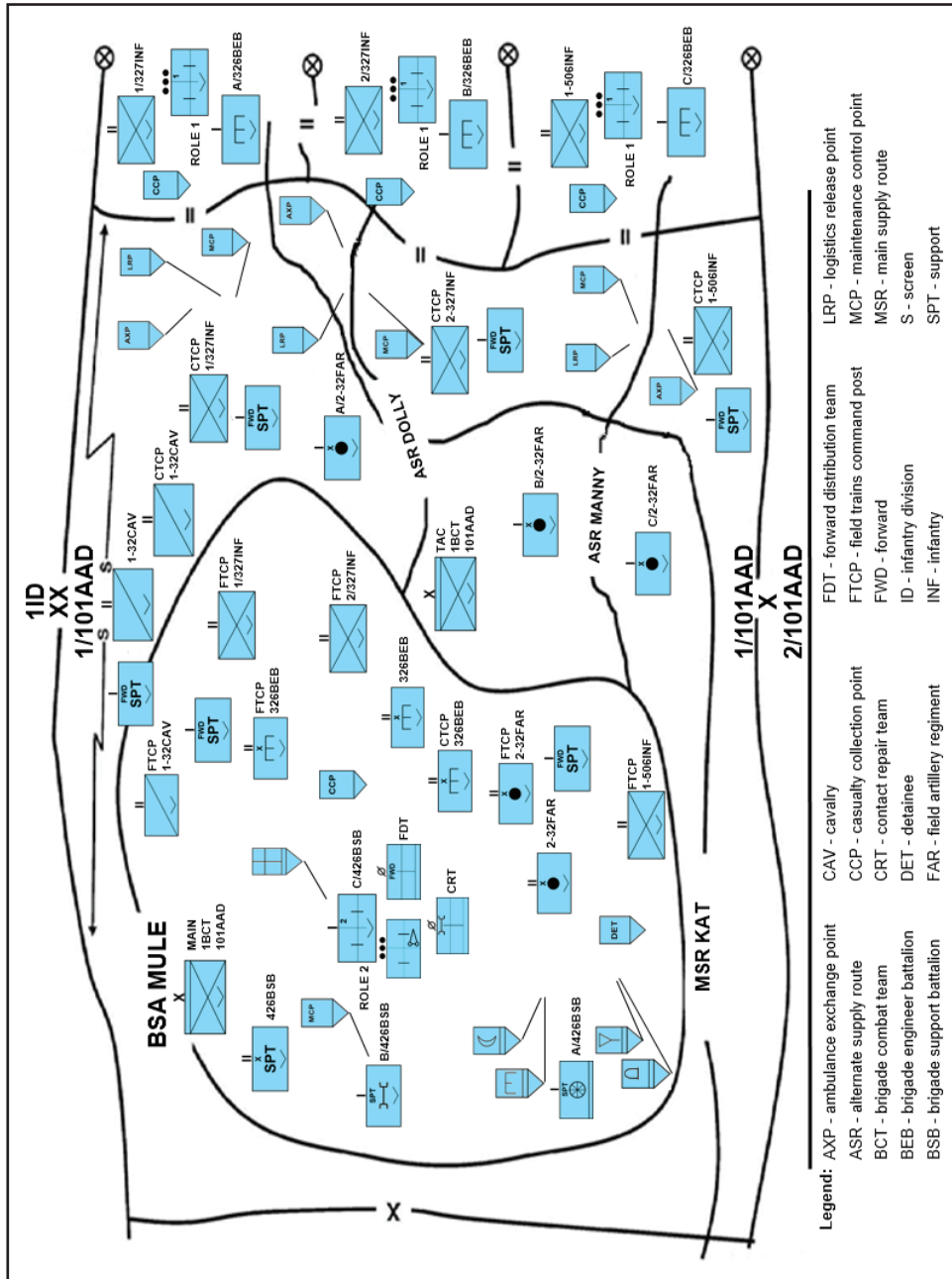

Figure 4-3. Sustainment overlay

4-76. In conjunction with the overall sustainment overlay is the AHS support plan. This is concise and comprehensive. The AHS support plan interfaces with logistics, financial

management, and personnel elements to coordinate AHS support across the warfighting functions. The explanation follows the same phasing as used in the overall plan or frames the actions around a before, during, and after battle timeline. Remember, the AHS support plan is written for commanders, not for logisticians. The details required by logistics planners and executors are provided in appropriate annexes. Additional subparagraphs provide more detailed sustainment information by functional area, as needed. These subparagraphs are usually omitted; this detailed information is published as part of the service support annex to the plan.

4-77. The MEDLOG concept of sustainment is one way to depict the flow of Class VIII from vendor to end user. This concept is a graphic representation of the tactical array of support areas and units. Ideally, it accompanies copies of the OPLAN and/or OPORD distributed to subordinate headquarters. It is used as a graphic backdrop to OPORD, paragraph 4, concept of sustainment (see figure 4-4 on page 4-24 for an example of a MEDLOG concept of sustainment).

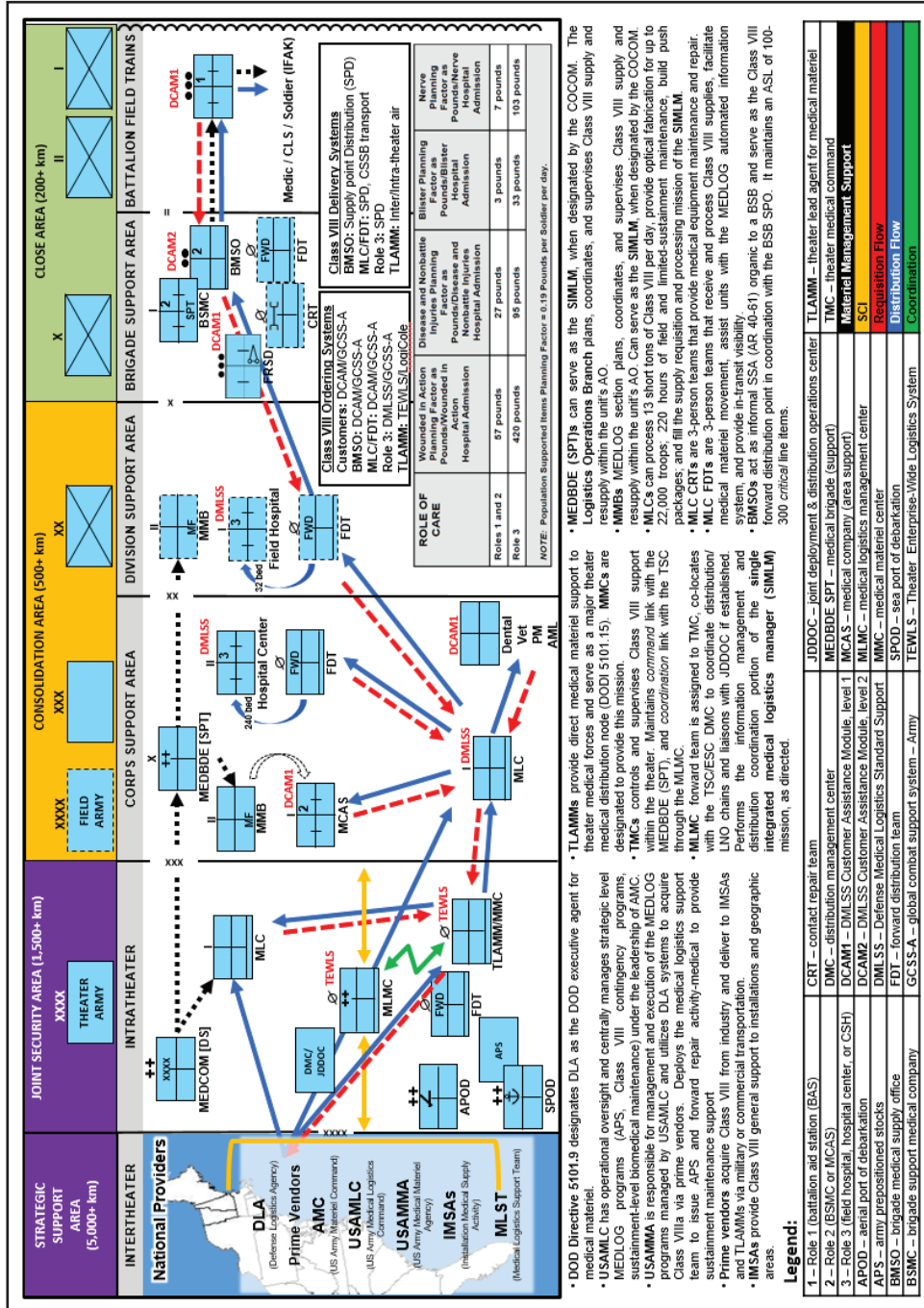

Figure 4-4. Medical logistics concept of sustainment

SUSTAINMENT REPORTING

4-78. The resupply of the medical platoon and the reporting of their status should be in accordance with the unit SOP; however, this should not limit the medical platoon from reporting or requesting supplies, as needed. The medical platoon may request supply needs through the appropriate yellow or red reports by voice or digital means. The PSG submits these reports by voice or digital communications based on the timeline in the unit SOP or immediately following enemy contact or a major loss/consumption of supplies. See appendix A for all standardized report formats.

SECTION III – MEDICAL PLATOON SUPPLY OPERATIONS

4-79. Medical platoons use a large amount of equipment and supplies, operate across the battalion's entire AO, and require frequent and substantial amounts of supplies to accomplish their assigned missions. Leaders at all levels report their classes of supplies that allow the logistics staff to anticipate expenditures and plan for resupply operations throughout an expected mission. There are planned and emergency resupply methods that the battalion uses to bring in LOGPACs and supplies. The HHC 1SG uses a technique (service station, tailgate, or combination of both) to get supplies to the medical platoon (see figure 4-4 on page 4-24).

RESUPPLY METHODS

4-80. Resupply operations fall into one of two methods of resupply: planned or emergency. Examples of planned resupply include scheduled LOGPACs, caches, modular system exchange (like flat-rack exchange), or pre-positioned supplies. Emergency resupply is not a planned method of resupply, but it is made available when there is a breakdown in coordination and collaboration between sustainment and maneuver forces or unit uses more supplies than expected. The HHC and medical platoon SOPs should specify cues and procedures for each method. The platoon rehearses resupply operations during platoon training exercises. The actual method selected for resupply in the field depends on the mission variables of METT-TC.

ROUTINE RESUPPLY

4-81. Routine resupply operations cover items in Classes I, III, V, VIII, and IX as well as mail and other items the medical platoon requests. Whenever possible, the HHC should conduct routine resupply daily, ideally during limited visibility. In some medical platoon variants, AMPV and Stryker medical vehicles use large amounts of fuel, so the platoon must resupply Class III at every opportunity.

Logistics Package

4-82. The LOGPAC technique is a simple, efficient way to accomplish routine resupply operations. The key feature is a centrally organized resupply convoy originating at the unit trains. It carries all items needed to sustain the medical platoon for a specific period, usually 24 hours or until the next scheduled LOGPAC. The HHC and battalion TACSOP should specify the exact composition and march order of the LOGPAC. Many

units operate on a 72-hour planning and execution time horizon for LOGPAC and convoy operations.

4-83. In LSCO the Role 1 BAS may only have windows of opportunity to evacuate patients. As a planning factor the medical platoon should consider using the LOGPAC as a means to evacuate routine patients who do not require movement by MEDEVAC platforms.

Preparation

4-84. The medical platoon must provide supply requests to the HHC in order to receive supplies. Based on the requests, the HHC then assembles the LOGPAC under the supervision of the forward support company (FSC) or the HHC commander. They obtain the following:

- Class I, Class III (bulk and packaged products), and Class V supplies from the forward support company. This usually entails employment of one or two fuel heavy expanded mobility tactical trucks and one or two cargo heavy expanded mobility tactical trucks.
- Class II, Class IV (basic load resupply only), Class VI, and Class VII supplies from battalion logistics staff personnel in the field trains.
- Class VIII medical supplies for the medical platoon, CLSs, and individual first aid kits.
- Routine Class IX supplies and maintenance documents (as required) from the prescribed load list section in the field trains.
- Replacement personnel and Soldiers returning from a role of care.
- Vehicles returning to the HHC area from maintenance.
- Mail and personnel action documents (including awards, finance, and legal documents) from the battalion personnel staff section.

4-85. When LOGPAC preparations are completed, the supply sergeant initiates tactical movement to the LRP under the supervision of the FSC support platoon leader. The supply sergeant and LOGPAC linkup with the HHC element (company XO, 1SG or security element from a platoon) at the LRP.

Actions at the Logistics Release Point

4-86. When the HHC representative arrives at the LRP to pick up the battalion LOGPAC, they update all personnel and logistical reports and are briefed by the field trains officer in charge on changes to the tactical or support situation. They then escort the convoy to the resupply point, providing security during movement from the LRP.

PLANNED RESUPPLY

4-87. The LOGPAC is a simple and efficient method to accomplish routine resupply operations. These operations include regular resupply of items in Classes I, III, V, VIII, and IX and any other items requested by the HHC and medical platoon. The battalion staff plans LOGPAC at their level and conducts sustainment operations at every opportunity. The LOGPAC comprises company and battalion assets that transport supplies to the unit, and the HHC distribute supplies to the medical platoon.

4-88. The tactical situation dictates which technique of resupply the HHC and medical platoon uses. The situation also determines when to conduct resupply. Generally, the medical platoon should avoid resupply during the execution of movement and plan to resupply during mission transitions.

EMERGENCY RESUPPLY

4-89. Emergency resupply is the least preferred method of supply. It is commonly referred to as immediate resupply and normally involves fuel and ammunition, and it is executed when the medical platoon has an urgent need for resupply and cannot wait for routine LOGPAC. It is conducted at the section and platoon level by redistributing ammunition between vehicles/squads to cross-level loads.

4-90. The PSG reports the need for emergency resupply to the HHC 1SG who relays the request to the battalion logistics staff. The unit's combat trains maintain a small load of Classes III and V for these situations. The logistics staff coordinates a linkup between the combat trains and the 1SG. The 1SG designates a LOGPAC site and provides guidance on what technique (tailgate, service station, or combination of the two) the medical platoon will use.

Note. Emergency resupply should only be used when the medical platoon expended more Class III and Class V than planned, and it should not become a routine substitute due to poor planning skills.

RESUPPLY PROCEDURES

4-91. Medical platoons must conduct resupply as quickly and efficiently as possible to ensure operational effectiveness and to allow the battalion LOGPAC to return to the logistics release point on time. In most cases, the HHC 1SG will only have about two hours to conduct sustainment operations, so efficiency at the resupply point is important. Once the medical platoon completes resupply operations, the 1SG prepares the LOGPAC vehicles for the return trip.

Note. Medical platoon leadership and senior medics should take full advantage of ambulances as they rotate from their supported unit to the Role 1 BAS and the Role 2 BSMC, also known as ambulance backhaul. This is a great opportunity to replenish expended Class VIII for medical and CLS aid bags and individual first aid kits and is considered the primary means of resupplying Class VIII.

RESUPPLY SITE SELECTION

4-92. The HHC 1SG chooses the logistics release point site to provide responsive support for the unit, to support the movement of wheeled resupply vehicles, and to limit exposure to enemy fires. The 1SG may task the medical platoon to conduct the on ground reconnaissance of the resupply site. The 1SG or medical platoon ensures the LOGPAC site meets the following criteria:

- Provides excellent cover and concealment.

- Reduces the platoon's thermal signature.
- Offers adequate dispersion for vehicles.
- Provides level terrain to allow refueling.
- Allows proximity to the medical platoon positions (3 to 8 kilometers [1.8 to 4.9 miles) behind the FLOT and the center of the AO).
- Offers a road or trail network to support the wheeled resupply vehicles and heaviest unit vehicles.

RESUPPLY TECHNIQUES

4-93. Resupply techniques are how the HHC gets supplies to its maneuver companies and the medical platoon to maintain their combat power. There are five techniques medical platoons utilize to conduct resupply operations: tailgate, service station, in-position, pre-positioned, and aerial. Certain situations may call for a portion of the medical platoon to receive resupply by one technique, and another portion to receive resupply by a different technique. Resupply operations are done in conjunction with the task and the mission variables of METT-TC.

TAILGATE TECHNIQUE

4-94. Medical platoons may use the tailgate technique while they are in static positions, such as a screen or an assembly area. The HHC ISG may use unit or support personnel and vehicles to go to the medical platoon's location to conduct resupply. The medical platoon can remain in position when using this technique and requires little or no movement. The PSG ensures each vehicle conducts resupply. If supply vehicles are unable to move near the medical platoon due to enemy fire or observation, the PSG may have to assist the resupply personnel in moving the supplies and equipment forward. Tailgate resupply technique is very time-consuming and requires an adequate road network for the wheeled supply vehicles to reach each medical platoon and its vehicles (see figure 4-5).

- 4-95. The following procedures will take place during the tailgate resupply technique:
- Medical vehicles remain in place. Petroleum, oils, and lubricants, ammunition, and supply trucks travel around the assembly area, or in the most feasible order, to each vehicle position and conduct resupply.
 - Crewmembers rotate quickly through the feeding area and pick up supplies, water, and mail. The medical platoon maintains security throughout the resupply process.
 - The PSG coordinates with the HHC ISG to pick-up Soldiers killed in action and their personal effects.
 - PSG ensures killed in action casualties are brought to a mortuary affairs collection point.
 - Ambulances pick up, treat, and evacuate seriously wounded in action Soldiers. All casualties are transported to the company medical assets to receive EMT and disposition. Soldiers are either returned to duty or evacuated to the next role of care for further treatment.

- Battalion/company trains will consolidate and secure detainees and transport them on returning supply vehicles according to the unit TACSOP.
- The unit armorer, communications technician, and supporting maintenance personnel repairs known problems and spot check other equipment.
- Medical platoon personnel dispatch vehicles according to the unit TACSOP.
- Mechanics can repair vehicles on site or evacuate vehicles to the MCP.
- The PSG monitors the resupply of the platoon.

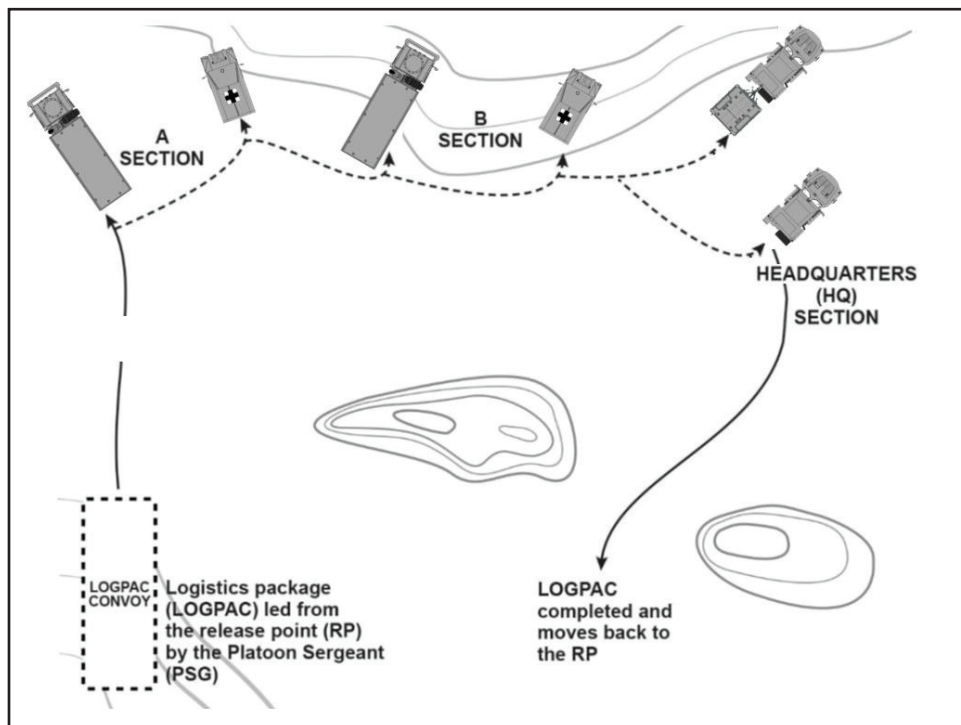

Figure 4-5. Tailgate resupply technique

SERVICE STATION TECHNIQUE

4-96. The service station resupply technique is inherently faster than the tailgate technique but can create security problems due to movement and concentration. During screening missions, the medical platoon must be careful not to compromise the location of the observation posts. Units typically use this technique during mission transition.

4-97. With the service station method, vehicles move individually or in small groups to a centrally located resupply point. This technique allows units to move individually to a centrally located resupply point (see figure 4-6 on page 4-30). Depending on the tactical situation, a unit moves out of its fighting position, conducts resupply operations, and moves back into position. This process continues until the entire platoon has

received its supplies. The technique is used when contact is unlikely and for resupply of one or several classes of supplies.

4-98. When using this technique, vehicles enter the resupply point following a one-way traffic flow; only vehicles requiring immediate maintenance stop at the maintenance holding area. Vehicles move through each supply location, with crews rotating individually to eat, pick up mail and sundries, and refill or exchange water cans. When all platoon vehicles and crews have completed resupply, they move to a holding area, where, time permitting, the platoon leader and PSG conduct a PCI. The HHC command group (company commander, XO, and ISG) also can take this opportunity to conduct PCIs of each platoon/section as it passes through the resupply point.

4-99. Resupply for an individual medical platoon's squads, sections, or teams happen at the LOGPAC while the remainder of the battalion's headquarters elements stays in position. The HHC ISG sets up the LOGPAC as shown in figure 4-6. Platoon vehicles complete with resupply and Soldiers from the trains not assisting in resupply operations provide LOGPAC security.

4-100. The following procedures take place during the service station resupply:

- The PSGs supervise the operation and coordinate with the HHC ISG for any special requirements.
- The platoon leader or PSG assigns certain vehicles to rotate through the LOGPAC at a designated location and follow the one-way traffic flow.
- Soldiers that need medical attention are transported to combat medics for treatment, or are prepared for further evacuation to the next level of care.
- The vehicle transporting killed in action moves to the mortuary affairs holding area, out of the view of the medical platoon, and transfers the human remains and personal effects.
- Vehicle commanders and section leaders make contact with the medical platoon leader for orders, logistic status, and situation report.
- Vehicles requiring maintenance support move to the maintenance area.
- The company armorer, communications technician, and supporting maintenance personnel repairs known problems and spot check other vehicles.
- When the platoon, squad, or section resupplies completely they move back to their designated position.

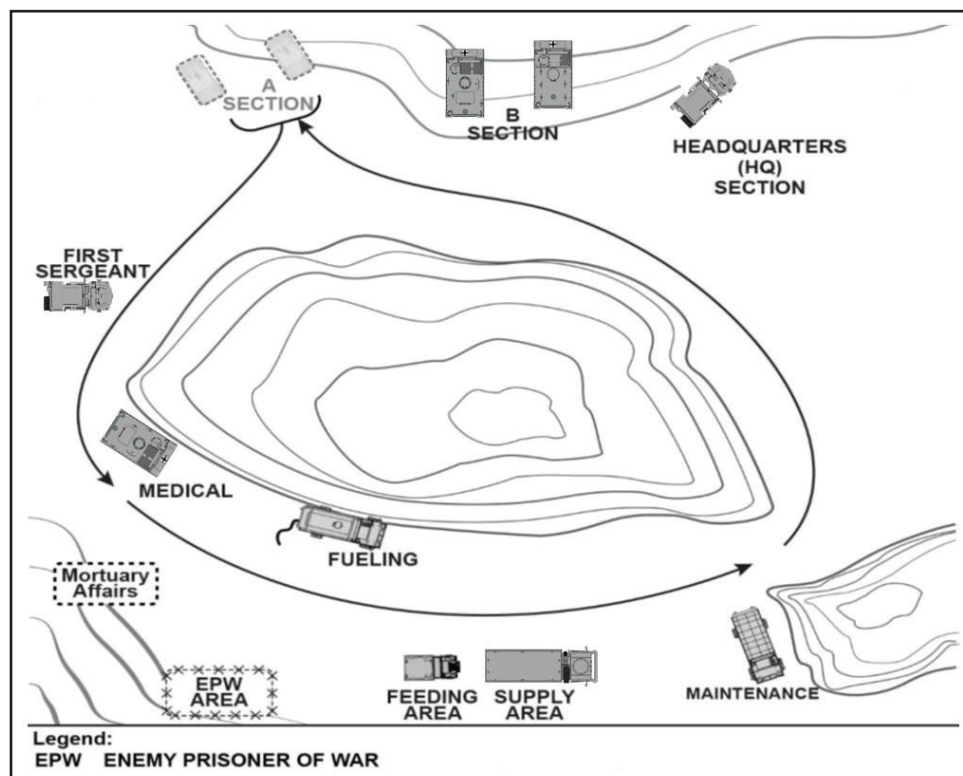

Figure 4-6. Service station resupply technique

Note. The platoon order should state the sequence for moving squads, sections, teams, or Soldiers from positions. Units may vary the technique by establishing a resupply point for each medical platoon or squad and moving the supplies to that point.

COMBINATION OF SERVICE STATION AND TAILGATE TECHNIQUES

4-101. The medical platoon leader can vary the specifics of the two basic techniques or use them in combination. For example, the platoon could use the tailgate technique when the aid station is set-up and use the service station technique for when the aid station is split or in transition (see figure 4-7 on page 4-32).

4-102. The medical squads rotate individually to eat, pick up mail and sundries, and refill or exchange water cans. When all platoon vehicles and squads complete resupply, they move to a holding area and establish security.

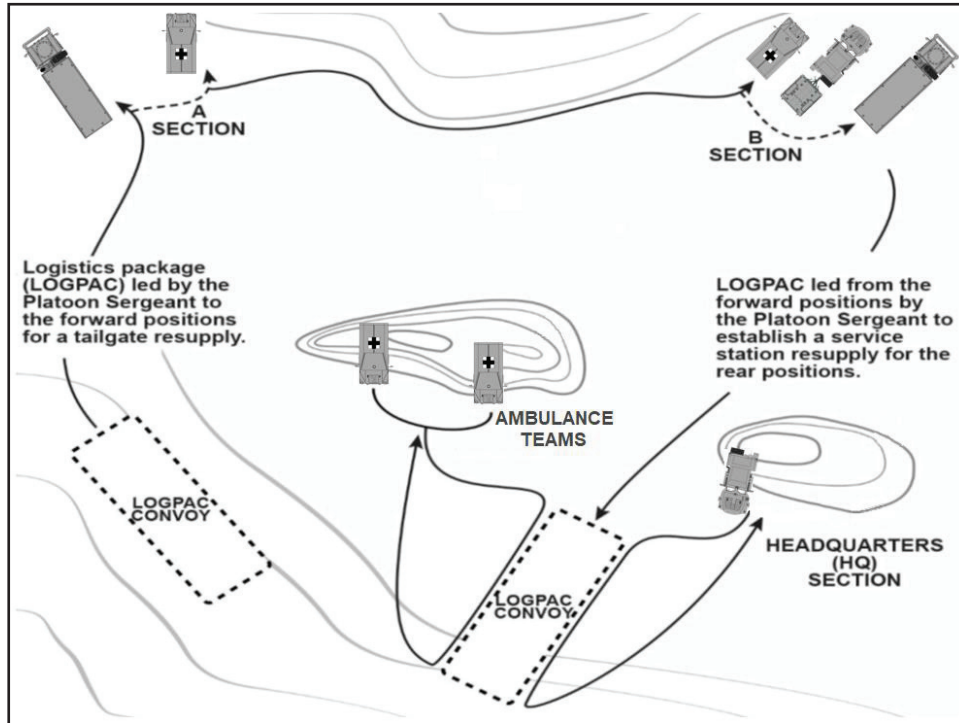

Figure 4-7. Combination of tailgate and service station resupply

IN-POSITION TECHNIQUE

4-103. In-position resupply is used during operations when contact with the enemy is imminent; the in-position resupply method (see figure 4-8) may be required to ensure adequate supplies are available to the squads. This method requires the HHC to bring forward supplies, equipment, or both to individual fighting positions. The platoon normally provides a guide to ensure the supplies are distributed to the most critical position first. This method—

- Is used when an immediate need exists.
- Is used to resupply single classes of supply.
- Enables leaders to keep squad members in their fighting positions.

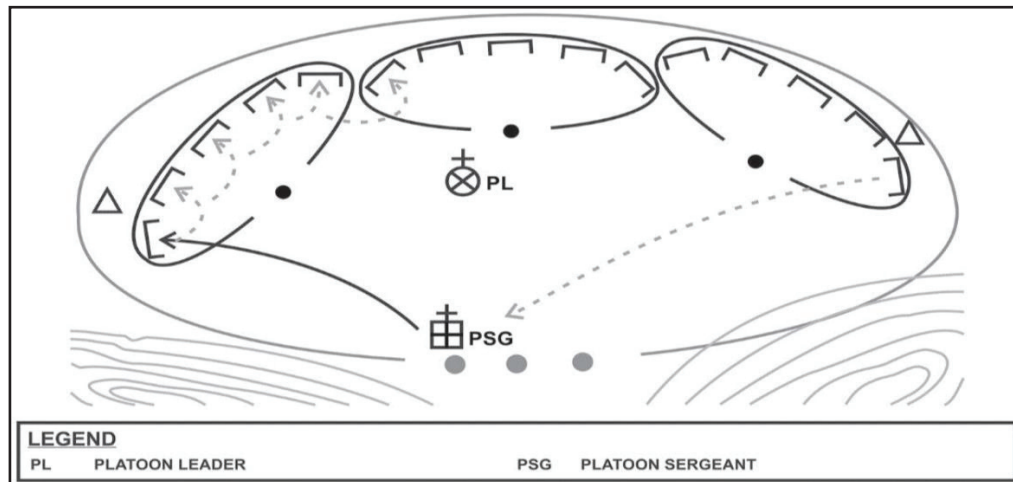

Figure 4-8. In-position resupply method

Note. If resupply vehicles cannot move near platoon positions, platoon Soldiers may need to help resupply personnel, move supplies and equipment forward.

PRE-POSITIONED RESUPPLY OR CACHE

4-104. At times, the medical platoon may need pre-positioned stock. These are also known as pre-positioned or “cached” resupply. Normally, the platoon only pre-positions Class IV and Class V items, but can also pre-position Class III and Class VIII supplies. During this type of resupply the platoon leader directs the PSG to rotate vehicles or squads or sections through prestock positions based on shortages within the platoon and the enemy situation. Security requires planning to prevent enemy dismounts from destroying or sabotaging prestocked supplies.

4-105. The medical platoon must carefully plan and execute pre-stock requirements and every medic must know the exact locations of prestock sites. During rehearsals, platoons verify cached locations and ensure the survivability of the prestocked supplies. These measures include selecting covered and concealed positions and digging in the prestock positions. The plan should include a grid to the location of the sites and have a removal and destruction plan to prevent the enemy from capturing pre-positioned supplies.

AERIAL RESUPPLY

4-106. Rotary- and fixed-wing assets can be a vital lifeline when medical platoon personnel are operating in the entire battalion AO for extended periods. Aerial assets are useful in resupplying dismounted medics in restricted terrain. This option is not always available due to availability of aircraft or degraded weather conditions. Careful choice of resupply routes, LZs, and drop zones (DZ) help minimize the risk of signature to the resupply aircraft.

4-107. Aerial resupply consists of moving personnel, equipment, materiel, and supplies by utility, cargo, and fixed-wing assets for use in operations. Overland resupply might not work due to terrain, distance, or the existing enemy threat. The medical platoon must initiate a request for resupply and must push it through HHC to the battalion. The platoon must prepare to receive the supplies at the specified time and location.

4-108. An aerial sustainment with speed balls is a technique with preconfigured loads to resupply in urban areas. Sustainment personnel prepackage supplies in aviation kit bags, duffle bags, or other suitable containers. Aircraft fly as close to the drop point as possible, reduce speed, drop supplies, and leave the area quickly. Supplies should be packaged in bubble wrap or other shock-absorbing material to minimize damage.

4-109. When employing aerial delivery, the following should be considered:

- The use of aerial delivery requires the coordination of the battalion staff, BCT operations staff, logistics staff, and air defense airspace management/brigade aviation element sections. Special focus should be considered when dealing with enemy air defense capabilities.
- The FSC must be prepared to both receive and package bulk supplies by sling-load operations or joint precision airdrop system. To conduct these operations, sling-load trained personnel are required in the FSC distribution platoon.
- The receiving unit must know how to select LZ/DZ zone to receive aerial resupply. The delivered supplies immediately are transported away from the LZ/DZ.
- Units should return the sling or air delivery equipment to its owning unit.

4-110. Planning for aerial resupply requires close coordination by the logistics staff, with elements reviewing the entire mission and resolving all limitations and problem areas. If a resupply item poses a problem that cannot be resolved, leaders should consider another mode of transport. Planning factors include the following:

- Priorities of cargo/unit resupply.
- Integration of the resupply operation into the tactical plan.
- Selection, identification, and marking of the PZ or LZ.
- Type/amount of cargo.
- Rotary wing assets available.
- Requirements for slings, cargo nets, and cargo containers.
- Ground crew training requirements, such as those for ground guides and hookup personnel.
- Pickup zone and LZ security.
- Flight routes.

4-111. The selection of a usable PZ or LZ is extremely important. The platoon leader or HHC commander analyzes logistical and tactical considerations taking into account if PZ or LZ positioning is at the right place to support the ground unit. The area also must be accessible to the aircraft involved in the resupply operation. The air mission

commander, the pilot in command, an aviation liaison officer, or a pathfinder-qualified NCO or officer will make the final decision on PZ or LZ selection and acceptance.

4-112. The medical platoon receiving the supplies is responsible for preparing the PZ or LZ. In addition to the general PZ and LZ responsibilities, Soldiers in the platoon perform the following specific tasks. For aerial resupply—

- Recover and assemble equipment and supplies.
- Train available ground crews in guiding the aircraft during approach, landing, unloading/loading, departure, and derigging the load.
- Train hookup personnel.
- Coordinate with the sending unit for control and return of the unit's transport equipment, such as slings and A-22 bags.
- Prepare, coordinate, and inspect backloads (such as slings and A-22 bags) and have them ready for hookup or loading when the aircraft arrives.

MEDICAL PLATOON RESPONSIBILITIES TO MEDICAL EQUIPMENT SET MANAGEMENT

4-113. Medical equipment sets and medical resupply sets apply to TOE units only and are designed and updated based on historical precedents (patient numbers, mission types, and injury types from past major combat operations), operational experience, and emerging medical technologies. Periodic review of these sets by medical subject matter experts ensure that the contents continue to meet the needs of medical professionals supporting the deployed force. Medical assemblage is also a term used to describe these medical sets as well as dental equipment sets, medical materiel sets (MMS), optical equipment sets, and others.

4-114. To support the command, the medical platoon leadership must become familiar with the commander's responsibilities as it pertains to MES management. The commander's responsibilities for accounting for and managing medical assemblage components are:

- Establish and maintain property accounting records for each authorized nonexpendable item using manual property accounting procedures or an approved DA-automated property accounting system (see DA Pam 710-2-1. The GCSS-A is the approved system for tracking nonexpendable items in a BCT.
- Establish a viable quality control program for all dated items.
- Manage ARC X or D MES components on-hand-receipts (under the inventory provisions of AR 710-2 and DA PAM 710-2-1), SC 6545-8 series of medical supply catalogs, or as part of the unit assemblage listing (UAL). These components are listed in the supply catalog or UAL to identify authorized quantities. Units are responsible for maintaining the assemblages they were fielded; however, commanders wishing to upgrade their sets may use the most recent UAL document.
- Ensure medical items classified as durable are not expended in the first use. Unless there is evidence of theft, the loss of these items is treated as if they

were expendable. Commanders are not required to account for durable losses from MESs and MMSs per AR 735-5.

- Inventory MES components against the fielded UAL at least every six months, 12 months in the reserve component (RC), to measure readiness. Units may perform this inventory in conjunction with other required inventories as long as it meets the requirements stated above.
- Dedicate items listed in the fielded UAL and SC 6545-8 series of medical supply catalogs that are associated support items of equipment end items; to the operation and maintenance of the medical assemblage. These associated support items of equipment NSNs are identified in the SC series. They have a special statement in the item description window designating “associated support items of equipment”. The information is for guidance only, and it does not constitute an additional authorization. The unit’s TOE reflect total authorizations.
- Record and account for inventories. The approved system for managing medical devices/materiel set inventory is the Medical Materiel Mobilization Planning Tool (M3PT). The M3PT is located on the Medical Operational Data System (MODS) website. The medical devices/materiel set management requirements are as follows:
 - Commanders designate those who will have write access to M3PT through MODS. Write access allows users to input/edit the unit’s inventory.
 - Unit personnel conduct an inventory of their fielded MES/MMS using component listings available in M3PT. They select the version of MES/MMS that they were fielded. If the fielded version is not available, it can be built in the set tool module of M3PT and downloaded into the Unit Assemblage Management Tool module.
 - Unit authorized personnel input the inventory results for each MES/MMS into the Unit Assemblage Management Tool. Inventory results include quality assurance/control information and medical maintenance for items as required by M3PT in the special handling codes column.
- Ensure all maintenance significant medical devices, as listed in the Maintenance Master Data File, are in compliance with the Army maintenance standard per AR 750-1.

4-115. Upon completion of inventory input, the unit uses the percentage of fill calculation in AR 220-1. It is generated by M3PT to determine the on hand status of each MES. Refer to AR 220-1 for component part availability.

4-116. The commander’s responsibilities for medical assemblage updates are as follows:

- Maintain the assemblages in the UAL configuration based on the set NSN fielded.
- Execute an NSN change to property-accountability records for sets fully upgraded to the new UAL configuration according to DA Pam 710-2-1.

SECTION IV – MAINTENANCE

4-117. The Army maintenance system generates/regenerates combat power and preserves the equipment to enable mission accomplishment. Maintenance of the medical platoon equipment, which includes medical equipment, is continuous. Every member of the medical platoon needs to know how to properly conduct unit-level maintenance according to the technical manual for all platoon equipment.

4-118. The maintenance of weapons and equipment (to include medical equipment) is continuous. Every Soldier must know how to operate and maintain their weapon and equipment according to the related technical manual. The platoon leader, PSG, and SQDLDRs must understand the maintenance requirements for every piece of equipment in the platoon.

4-119. Maintenance includes inspecting, testing, servicing, repairing, requisitioning, recovering, and evacuating vehicles and equipment (including medical equipment). Maintenance at the medical platoon level comprises thorough preventive maintenance checks, and services and the accurate reporting of maintenance problems to the HHC.

4-120. Maintenance is the early identification of problems that prevent equipment downtime and the reduction of combat effectiveness. The result of good PMCS is properly completed equipment inspection and maintenance forms (DA Form 2404 or DA Form 5988-E). The DA Form 2404 or DA Form 5988-E follow a pathway from crew level to the BAS and back. Per unit SOP, the HHC XO or 1SG supervises the flow of these critical maintenance documents and parts. The flow of reporting and repairing equipment includes the following:

- The SQDLDRs or vehicle commanders collect the DA Form 2404 or DA Form 5988-E and send them via Joint Battle Command - Platform (JBC-P) or give them to the PSG, who consolidates the forms for the platoon.
- The PSG forwards a DA Form 5988-E or gives a DA Form 2404 to the HHC XO or 1SG, who reviews and verifies problems and deficiencies and requests parts needed for maintenance and repairs.
- The DA Form 5988-E is consolidated at company level and then transmitted to the battalion and its supporting CRT/forward maintenance team (FMT).
- During the next LOGPAC operation, the completed DA Form 2404 is returned to the CRT/FMT to document completion of the repair.
- In the BSA, required repair parts are packaged for delivery during the next scheduled resupply or through emergency resupply means.
- The operator conducts initial 10-level maintenance, repair, and recovery actions on-site. Once it is determined that the crew cannot repair or recover the vehicle or equipment, the platoon contacts the XO or 1SG. If additional assistance is needed, the CRT/FMT may be dispatched to assess the damaged or broken equipment and makes necessary repairs to return the piece of equipment to fully mission-capable or mission-capable status, if appropriate.

4-121. The unit SOP should detail when maintenance is performed, to what standards, and who inspects it. The SQDLDR is most often the one who inspects maintenance

work, with the PSG and platoon leader conducting spot checks. Besides operator maintenance, selected Soldiers are trained to perform limited maintenance on damaged weapons and battle damage assessment and repair.

4-122. Inoperative equipment is fixed as far forward as possible. When a piece of equipment is damaged, it should be inspected to see if it could be repaired on the spot. If equipment cannot be repaired forward, it is evacuated immediately or returned with a LOGPAC. Even if the item cannot be evacuated at once, the maintenance system is alerted to prepare for repair or replacement. If a replacement is available (from an evacuated Soldier or inoperative equipment), the equipment is sent forward. If not, the leader must work around it by prioritizing remaining equipment. For example, using a squad radio for the company command net if the platoon radio is broken.

4-123. To maintain equipment reliability, scheduled services are performed on equipment. Equipment services are specified maintenance actions performed when required where equipment, components, and systems are routinely checked, adjusted, lubed, according to the technical manual (TM) or manufacturer specifications. Maintenance personnel use scheduled services to replace faulty items and avoid projected component failures based on analysis and engineering documentation.

MAINTENANCE CATEGORIES

4-124. There are two categories of Army maintenance—sustainment maintenance and field maintenance. Field maintenance primarily replaces parts on the user's system, and sustainment maintenance repairs components off the user's platform. Refer to Chapter 5 of ATP 4-02.1 for a more detailed description of Army medical equipment maintenance and repair support.

SUSTAINMENT MAINTENANCE

4-125. Sustainment maintenance consists of off-system component repair or end item repair and return to the support system or by exception to the owning unit, performed by national level maintenance providers. The MLC provides limited sustainment maintenance and is supported by a USAMMA Forward Repair Activity-Medical collocated with the medical materiel center or theater lead agent for medical materiel. Sustainment maintenance of nonmedical equipment is performed by national level maintenance providers, to include Army Materiel Command, to return items to a national standard and to execute maintenance actions that cannot be performed at field level of maintenance.

VEHICLE/EQUIPMENT PREVENTIVE MAINTENANCE CHECKS AND SERVICES

4-126. The maintenance of equipment and weapons is continuous. All platoon members must know how to maintain their equipment and weapons according to the related TM and/or operator's manual. The medical platoon leader, PSG, and SQDLDRs must understand how to conduct maintenance for every piece of equipment in the platoon.

4-127. Maintenance includes inspecting, testing, servicing, repairing, requisitioning, recovering, and evacuating vehicles and equipment. Maintenance at the medical platoon level comprises thorough PMCS and accurate reporting of maintenance problems to the HHC.

4-128. Maintenance and the early identification of problems prevent equipment downtime and the reduction of combat effectiveness. The result of good PMCS is a properly completed equipment inspection and maintenance forms. These forms (DA Form 2404 or DA Form 5988-E) are the primary means through which the platoon obtain maintenance support or repair parts. The forms are entered into GCSS-A and follow a pathway from crew level to the BAS and back. Per unit SOP, the HHC XO or 1SG supervises the flow of these critical maintenance documents and parts. The flow of reporting and repairing equipment includes the following:

- Operator conducts PMCS on the vehicle or equipment and records faults on a DA Form 5988-E or DA Form 2404.
- SQDLDRS, TLs, and vehicle commanders collect the maintenance forms and send them digitally or give them to the PSG, who consolidates the forms for the platoon.
- The PSG forwards an electronic version or gives a hard copy of the forms to the XO or 1SG, who reviews and gives the forms to the mechanics to verify problems and deficiencies and requests parts needed for maintenance and repairs.
- The electronic versions of the forms are consolidated at company level and then transmitted to the battalion and its supporting FMT.
- During the next LOGPAC operation, the completed hard copy forms are returned to the FMT to document completion of the repair.
- In the BSA, required repair parts are packaged for delivery during the next scheduled resupply or through emergency resupply means.
- If the repair or installation of the part requires higher skills and equipment than the operator, a CRT/FMT is dispatched to assess the problem and to repair or install the part on-site.

4-129. The unit SOP should detail when maintenance is performed, to what standards, and who inspects it. The SQDLDR/TL is most often the one who inspects maintenance work, with the PSG and platoon leader/platoon commander conducting spot checks. Besides operator maintenance, selected Soldiers are trained to perform limited maintenance on damaged weapons, battle damage assessment and repair, and medical maintenance. Inoperative equipment is fixed as far forward as possible if METT-TC allows. When a piece of equipment is damaged, it should be inspected to see if it could be repaired on the spot. If equipment cannot be repaired forward, it is evacuated immediately.

FIELD MAINTENANCE

4-130. Field maintenance consists of on-system maintenance, repair, and return to the user including maintenance actions performed by operators. Field maintenance is often performed on or near the unserviceable piece of equipment or weapon system utilizing line replaceable units or modules and component replacement or repair (ATP 4-33). The greatest enabler of field maintenance is operator/crew PMCS. The operator/crew PMCS provides the most rapid identification of equipment faults and engagement of the maintenance repair system.

4-131. The medical platoon requests medical equipment maintenance support from the supporting BCT BMSO. Medical equipment maintenance and repair support will be possible on a limited basis while the treatment squad is forward deployed in the area of operations. However, during stand-down periods, a CRT from the MLC can be requested to provide field and limited sustainment maintenance at the unit's location. Normally, minimal equipment contained in these sets requires sustainment maintenance. User/operator maintenance tasks and field maintenance repair parts will be identified in the technical manual or operator manuals and applicable materiel fielding plans.

4-132. Medical squad and section leaders are the platoon's first-line maintenance supervisors. The medical platoon's maintenance status and combat readiness depends on their commitment to proper maintenance procedures. The squad and section leader duties in this area include:

- Ensuring operators fill out and update DA Form 5988-E and DA Form 2408-18 (*Equipment Inspection List*) according to DA Pam 750-8.
- Training the squad and section in proper PMCS procedures for both assigned vehicles and medical equipment.
- Ensuring the training and licensing for all crewmembers as drivers in preparing for continuous operations. At a minimum, ensuring the assigned vehicle driver or equipment operator is licensed.
- Ensuring the training and licensing for all platoon members on all organic medical equipment assigned to the platoon in preparing for continuous operations.
- Installing repair parts upon receipt or store in authorized locations.
- Ensuring all tools and basic issue items are properly marked, stored, maintained, and accounted for.
- Ensuring the operator always fills their vehicles fuel tank and/or receives as much fuel as possible, and at every opportunity.
- Updating the PSG on the maintenance and logistics status of the vehicles and medical equipment.

4-133. Operator maintenance includes the proper care, use, and maintenance of assigned vehicles and crew equipment, such as weapons, optics, CBRN equipment, night vision devices, and medical equipment. The driver and other crewmembers perform daily PMCS, such as inspecting, servicing, tightening, lubricating, cleaning, preserving, and adjusting vehicles and equipment. The driver and vehicle commander are required to use a DA Form 5988-E to record these checks and services as well as all

equipment faults that cannot be immediately corrected. These reports are the primary means for reporting equipment faults through the vehicle commander/section leader to the PSG, platoon leader, and ultimately to organizational maintenance personnel. Checks and services prescribed for the automotive system, weapon systems, and turret are divided into three groups—before mission, during mission, and after mission.

Weapons Maintenance

4-134. Platoon leadership provides time for platoon members to conduct weapons maintenance. Environmental conditions will have serious effects on weapons, and platoon leadership will counter those effects by providing time to conduct maintenance on weapons. Proper weapons maintenance includes disassembling, cleaning, lubricating, reassembling, and function checking the individual weapons according to the weapons technical manual. Leadership has to also schedule time to reconfirm zeros on sights and to conduct weapon test fires prior to missions. Weapons cleaning, lubrication, and zeroing are high on the priority of work lists established from the PSG and issued to subordinate leaders. Maintenance of weapons will ensure proper and accurate firing of weapons systems:

- Before mission.
- During mission.
- After mission.

Equipment (Vehicle/Communication) Maintenance

4-135. Equipment maintenance platoon leadership provides time for platoon members to conduct equipment and vehicle maintenance. Environmental conditions will have serious effects on vehicles and equipment, and platoon leadership will counter those effects by providing time to conduct maintenance on vehicles and equipment:

- Before mission.
- During mission.
- After mission.

Medical Equipment Maintenance

4-136. All AHS members are responsible for ensuring that medical maintenance is conducted so that all medical devices are safe and reliable. It is the responsibility of the medical platoon leadership to develop and expand their knowledge and skills required for the lifecycle management, sustainment and accountability of medical devices and medical device systems that enable medical treatment and evacuation. Army commanders ensure that maintenance supports readiness per AR 750-1 and AR 220-1. Commanders are accountable for the conduct of maintenance operations, including medical maintenance, and emphasize it at all echelons.

4-137. At the Role 1 BAS, the platoon leader, with the support of the PSG is responsible for ensuring operator maintenance is performed on assigned equipment and that a medical maintenance support plan is in place and coordinated with the Role 2 BSMC, BMSO, and supporting organizations. The keys to Class VIII medical maintenance are user/operator preventive maintenance checks and services with

coordination between supporting organizations for the required system maintenance, calibration, and repairs. A CRT from the MLC may be available for medical equipment repair and maintenance when conditions and commitments allow the CRT to travel to the unit's location; otherwise, retrograde of the medical equipment is required. The BMSO must provide medical equipment support services for the medical platoon when support from a MLC is not available. Ambulance backhaul is the primary method of transporting medical equipment in need of maintenance from the Role 1 BAS to the BMSO, the LOGPAC is the alternate method. Once repaired the item is returned via ambulance backhaul (primary) or LOGPAC (alternate) from the BMSO to the Role 1 BAS.

4-138. Operational medical maintenance conducted while deployed will consist of operator-/user-level maintenance. See ATP 4-02.1 for additional information. Medical platoon personnel will exercise their responsibilities by performing operator PMCS. This includes maintaining equipment by performing routine services like cleaning, dusting, washing, and checking for frayed cables, loose hardware, and cracked or rotting seals.

4-139. Platoon leadership provides time for platoon members to conduct medical maintenance. Environmental conditions will have serious effects on medical equipment and platoon leadership will counter those effects by providing time to conduct medical maintenance. Medical maintenance is the periodic inspections conducted according to the piece of medical equipment's technical manual and/or manufacturer's instructions. For the medical platoon, medical maintenance is high on the priority of work lists established from the PSG and issued to subordinate leaders. Maintenance of medical equipment is considered a combat multiplier for the medical platoon. The medical platoon leadership responsibilities include the following:

- Place an emphasis on the command's medical maintenance program.
- Read, understand, and apply the brigade's maintenance directive for medical devices. An example of a maintenance directive can be found in TB MED 750-2.
- Provide the battalion the resources required to maintain an effective medical maintenance operation per AR 750-1. These include:
 - Manpower.
 - Tools.
 - Test, measurement, and diagnosis equipment.
 - Funding.
 - Training.
 - Space.
- Inventory MES and MMSs by serial number and annotated in the M3PT (see SB 8-75-11).
 - For M3PT access, go to the MODS webpage and select the M3PT application. Follow the instructions to submit a systems access request.
 - Report MES and MMS equipment readiness to higher headquarters in—
 - AR 220-1.

- AR 700-138.
- DA Pam 220-1.
- Use the TEWLS to—
 - Manage and track personnel utilization.
 - Manage and track scheduled and unscheduled work orders.
 - Report Army Materiel Status System data.

Medical Devices Hand Receipt Holder's and Supervisor's Responsibilities

4-140. Section NCOs, staff, and equipment operators are the most important part of the maintenance process. Operator maintenance is the keystone to an effective medical maintenance program. It is essential for keeping medical devices in peak operating condition. The hand receipt holder and supervisors:

- Account for, maintain, and properly inventory medical devices.
- Ensure that equipment is reported to the assigned maintenance officer for inclusion into the medical maintenance program. The battalion commander designates an assigned maintenance officer for equipment belonging to a BAS. The BSMC reports equipment to the BMSO.
- Establishes an account with the supporting biomedical equipment maintenance activity.
- Ensure that operator-level PMCS is conducted each week and annotates it on the training schedule. PMCS is conducted and annotated on DA Form 5988-E per —
 - TB MED 750-2.
 - Unit Maintenance SOP(s).
- Follow the manufacturer's operator literature. Medical devices literature can be found on the USAMMA website. If repair is required, opens a work order through the ground TEWLS system:
 - If equipment belongs to a BAS, ensures that the open work order is evacuated to the BSMC's TEWLS.
 - Takes broken devices to the BMSO biomedical devices maintenance shop for repair.
 - If required, requests maintenance regeneration enabler through the BMSO.

Note. The issuing of field rations is a supply transaction. The chain of command is notified if a change to the property book is needed.

- Ensure that medical equipment operators are trained on the use and care of medical devices.
- Ensure the availability of medical devices literature for reference (see the USAMMA website).

- Ensure that operators are familiar with and trained to use their medical devices. Upon request, the BSMC biomedical equipment NCO is available to assist with operator-level maintenance. The medical platoon can request support through the appropriate channels, such as the battalion operations staff, for tasking or coordination.
- Ensure medical devices operator and maintainer training is available for standardized TOE medical devices on Joint Knowledge Online.

Note. Medical devices operator and maintainer training is available for standardized TOE medical devices on Joint Knowledge Online.

- Ensure the proper storage and use of equipment:
 - To maintain the life of the equipment and its components proper storage is important. The guidance for proper storage temperature is in the medical devices literature and medical equipment handbooks, which are available on the USAMMA website.
 - It is essential that all required components, accessories and consumables be readily available for the equipment to be at 10/20 standards. Equipment without authorized consumables is considered non mission capable for supply.
 - It is recommended that areas with different makes or models of equipment keep their accessories separated and labeled. Using the wrong parts or accessories can result in patient safety issues or cause equipment damage.
 - It is the section's responsibility to ensure the correct types and quantities of supplies are readily available. They consult with the company/medical supply NCO for initial supply and resupply procedures.

Global Combat Support System-Army

4-141. All BCT activities owning medical devices use the GCSS-A for medical maintenance operations and management. The following procedures ensure that equipment and equipment maintenance services are loaded into the GCSS-A. They ensure that all scheduled and unscheduled maintenance transactions are captured accurately. They are routed through the administrative controls channels to Logistics Data Analysis Center/Army Enterprise Systems Integration Program: Army Enterprise Portal. It allows units to roll up medical devices information with other equipment commodities' information for unit status reporting. Discussed below are tasks to be completed:

- Coordinate with the supporting Sustainment Automation Support Management Office to configure the medical maintenance Standard Army Maintenance System in a Host/Client relationship according to specific guidance from the Medical Maintenance Policies and Analysis on the Army Medical Logistics Command website.
- Describe host/client configuration for units with medical maintenance support.

- Establish unit client/host relationship, maintenance significant medical devices are loaded into the nonmedical equipment Standard Army Maintenance System. It is accessed by the medical maintenance Standard Army Maintenance System. Maintenance of significant medical devices are identified and verified through coordination with the unit property book owner and component hand receipt.
- Create and use the following predefined tasks:
 - Scheduled parts replacement.
 - Calibration.
 - Preventive maintenance.
 - Inspection.
- Work with the Information System Operator-Analyst (MOS 25B) to identify all supported users and coordinate Standard Army Maintenance System communication contact information between the supporting and supported unit's computers.
- Coordinate maintenance support schedules with supported customers. When in garrison, conduct medical maintenance in conjunction with motor stables.
- Provide routine equipment status updates through the daily interface to supported customers.

VEHICLE RECOVERY

4-142. Recovery is the process of freeing or retrieving immobile, inoperative, or abandoned equipment from its current position and returning it to service or to a maintenance site for repairs. These actions typically involve extracting, towing, lifting, or winching. Platoon member should limit towing to only to a field maintenance site or the nearest MCP.

4-143. Damaged and inoperable equipment on the battlefield can strain dedicated recovery resources. The platoon should know the locations of dedicated recovery assets in the AO to effectively support battlefield recovery operations. Platoon leadership must emphasize the use of self- and like-vehicle recovery methods to the greatest extent possible. These practices will minimize the use of dedicated recovery assets for routine recovery missions.

WARNING

Recovery operations on the battlefield and in general can be extremely hazardous. Conduct a risk assessment, and safety must remain a top priority for each recovery mission. Proper maintenance of recovery vehicles and serviceability of authorized rigging and other equipment is essential to ensure safe recovery missions. Consider operational variables prior to and during all recovery operations.

4-144. Prior to missions, the medical platoon leader and PSG should know what the plan of action for repair and recovery of disabled equipment. This information is put out during the OPORD and through subsequent rehearsals. It is critical that PCCs include inspection of tow bars and extraction straps to ensure they are complete and are rated for the types of vehicles operating in and attached to the medical platoon. The platoon leadership needs to know the location of the closest MCP. Depending on the level or the severity of battle damage, recovery is usually by the following methods: self-recovery, like-vehicle recovery, dedicated-recovery, and expedients.

SELF-RECOVERY

4-145. Self-recovery starts at the location where the equipment becomes mired, disabled, or damaged. The operator and crew use the basic issue items and additional authorized list or on-vehicle equipment items to perform self-recovery. When the equipment has a mechanical failure, the operator and crew will use the equipment's technical manual to perform troubleshooting procedures with the tools available in the basic issue items and additional authorized list or on-vehicle equipment. When self-recovery fails, the operator and crew can request assistance from available like vehicles.

LIKE-RECOVERY

4-146. Use like-vehicle recovery when self-recovery fails. The principle is to use another piece of equipment "of the same weight class or heavier" to extract the mired, disabled, or damaged equipment by using tow bars, chains, tow cables, and/or allied kinetic energy recovery rope. When self-recovery and like-recovery are not practical or are unavailable, put in a request to use dedicated-recovery assets.

4-147. The most common form of self-recovery is recovery of like vehicle with a tow bar. Before using a tow bar (or any piece of recovery equipment), medical platoon personnel ensure the following:

- Ensure the tow bar safe to use.
- Has all the required safety pins and clips.
- The tow bar is approved and has the capacity to tow the disabled vehicle.
- The towing vehicle weight must be equal to or greater than the weight of the vehicle being towed.

DEDICATED-RECOVERY

4-148. Dedicated recovery uses vehicles specifically designed and equipped for towing other vehicles. Wheeled wreckers and tracked recovery vehicles are examples. These are used when self-recovery or like-vehicle recovery is not possible because of the severity of the situation, safety considerations, or the inability to use like-vehicle assets employed in their primary mission. In general, wheel recovery systems recover wheeled vehicles, and track recovery systems recover tracked vehicles. Requests from the PSG or platoon leader for dedicated recovery systems located with the forward support company go to the XO.

Note. Check the vehicle technical manual prior to recovery and towing operations. Crewmembers need to check towing requirements such as disabling of the transfer case, disengaging of final drives, and hooking up air lines.

SECTION V – DISPOSITION OF HUMAN REMAINS

4-149. Mortuary affairs provides for the search for and recovery, identification, preparation, and disposition of human remains of persons for whom the Services are responsible by status and executive order. The tempo and lethal nature of LSCO increases the propensity for mass casualties, requirements for mortuary affairs, increased requirements for a robust medical architecture, and large-scale personnel and equipment replacements. The availability of transportation platforms and the tactical and operational situation determine if and when the evacuation of fatalities occurs during LSCO. If casualty estimates indicate the capacity for human remains processing by mortuary affairs companies will be exceeded during LSCO, and the establishment of an in-theater mortuary may be required. For more information on mortuary affairs, see DODD 1300.22C1 and JP 4-0.

BATTALION AID STATION RESPONSIBILITIES

4-150. There will be casualties who have died before reaching the BAS (dead on arrival) or who die of wounds before they can be stabilized and further evacuated. A temporary morgue area should be established away from and out of sight of the triage and treatment areas. This area could be established behind a natural barrier, such as a stand of trees, or it can be set off by using tentage or tarpaulins. This area is not an actual morgue, as it neither has the required equipment nor is it staffed and is for use only by the BAS for those patients who have died. It is not a temporary collecting point for deceased personnel from other units. It is only a holding area that should have at least one nonmedical guard for site security. The DD Form 1380 must be completed for each deceased personnel and a physician must sign it. Human remains should be placed in a human remains pouch or cover with a blanket, tarp, or other material to honor and protect the dignity of the fatality and decrease the physiological impact to the living assisting with the mortuary affairs mission. Their remains are held until mortuary affairs support can be obtained.

BATTALION AID STATION RELOCATION

4-151. If the BAS relocates, an eight-digit grid coordinate should be obtained along with a list of names (if known) and how many bodies. This information is sent to the logistics staff for tracking and submission to a casualty liaison team and subsequently to the mortuary affairs operations division. If METT-TC allows, the unit should ensure the following:

- Friendly and enemy human remains are separated.
- One identification tag for friendly human remains stays with the body.

SECTION VI – ARMY HEALTH SYSTEM SUPPORT TO DETAINEES

4-152. It is DOD policy that members of the DOD components comply with the law of war during all armed conflicts, however such conflicts are characterized and in all other military operations. Consequently, captured or detained personnel shall be treated humanely and in accordance with United States law, the law of war, and applicable United States policy. Personnel in United States custody shall receive health care consistent with the standard of health care that applies for members of the United States Military Services in the same geographic area. For additional information refer to DODD 2310.01E and DODD 2311.01E; AR 40-400 and AR 190-8; FM 3-63, FM 4-02, and FM 6-27/MCTP 11-10C; and ATP 4-02.46.

PRINCIPLES OF DETAINEE HEALTH CARE

4-153. Department of Defense Instruction 2310.08 establishes basic principles for health care personnel engaged in the provision of detainee medical care. According to DODI 2310.08E, health care personnel—

- Have a duty to support the DOD’s responsibility to ensure that no individual in DOD custody or physical control, regardless of nationality or physical location, will be subject to cruel, inhuman, or degrading treatment or punishment, in accordance with Section 2000dd of Title 42, United States Code.
- Will provide health care services for detainees and have a duty to provide appropriate medical care and attention required by the detainee’s condition. To the extent practicable, treatment of detainees should be guided by professional judgments and standards similar to those applied to all operating forces and consistent with DODI 6025.27, including:
 - Consistent quality care.
 - Respectful treatment.
 - Security and safe environments.
- Will make and determine the scope of health care services provided after consideration of the procedures and standards set forth in Bureau of Prisons Program Statement 6031.04.
- Will exclusively maintain a professional provider-patient treatment relationship with detainees for the purpose of evaluating, protecting, or improving their physical and BH.
- Will apply their knowledge and skills in a manner that is in accordance with applicable law or the standards in DODD 2310.01E and DODI 2310.09.
- Will not certify, or participate in the certification of, the fitness of detainees for any form of treatment or punishment that is not in accordance with applicable law or participate in any way in the administration of any such treatment or punishment. Certifications in accordance with applicable law include, but are not limited to, clearance for a work detail, transportation,

questioning, or interrogation. All detainee medical care and examinations must be documented in their medical record.

- Must safeguard medical information in accordance with the procedures in DODI 2310.08E.
- Will not participate in any procedure applying physical restraints to a detainee, unless such a procedure is determined to be necessary by a licensed provider, for the physical or mental protection or safety of the detainee, other detainees, or those treating, guarding, or otherwise interacting with them. Such restraints, if used, will be applied in a safe and professional manner.
- Must be licensed in accordance with Section 1094 of Title 10, United States Code, or provide assistance to a licensed provider within their scope of duties and competencies. When performing health care functions in support of detainee operations, these actions are limited to providing direct support for—
 - Providing health care services in a professional provider-patient treatment relationship in approved settings.
 - Conducting disease prevention and other approved public health activities.
 - Advising authorized command authorities regarding the health of detainees.

CATEGORIES OF DETAINEE HEALTH CARE

4-154. The detainee health care system defines five major categories of care that may potentially be provided to detainees. These categories are:

- Medically Necessary—Acute or Emergent. Medical conditions that are of an immediate, acute, or emergent nature that without care would result in the rapid deterioration of the detainee's health, significant irreversible loss of function, or may be life threatening. Conditions in this category are included in the scope of services provided to detainees.
- Medically Necessary—Non-emergent. Medical conditions that are not immediately life threatening but without care the detainee could not be maintained without significant risk of serious deterioration leading to premature death; significant reduction in the possibility of repair later without present treatment; or significant pain or discomfort which impairs the detainee's participation in activities of daily living. Conditions in this category are included in the scope of services provided to detainees.
- Medically Acceptable—Not Always Necessary. Medical conditions that are considered elective procedures, when treatment may improve the detainee's quality of life. Conditions in this category are usually excluded from the scope of services provided to detainees.
- Limited Medical Value. Medical conditions in which treatment provides little or no medical value, are not likely to provide substantial long-term gain, or are expressly for the detainee's convenience. Conditions in this category are usually excluded from the scope of services provided to detainees.

- Extraordinary. Medical interventions are deemed extraordinary if they affect the life of another individual, such as organ transplantation, or are considered investigational in nature. This category will not be provided unless directed by the appropriate authority.

RESPONSIBILITIES OF HEALTH CARE PERSONNEL

4-155. Health care personnel are well trained in and guided by the ethics of their professional calling. This training and ethical principles, coupled with the requirements of international law as it pertains to the treatment of enemy prisoners of war, detainees, and civilians during conflict, will ensure the ethical treatment of all sick and wounded personnel.

4-156. Health care personnel perform their duties consistent with the following principles:

- Will perform duties in all matters affecting the physical and BH of detainees to perform, encourage, and support, directly and indirectly, actions to uphold the humane treatment of detainees. See ATP 4-02.46, Appendix B for additional information on detainee BH care.
- Will provide the medical care of detainees to protect detainees' physical and BH and provide appropriate treatment for disease. To the extent practicable, treatment of detainees should be guided by professional judgments and standards similar to those applied to personnel of the United States Military Services.
- Will not be involved in any professional provider-patient treatment relationship with detainees the purpose of which is not solely to evaluate, protect, or improve their physical and BH.
- Will not apply their knowledge and skills, whether or not in a professional provider-patient treatment relationship, in a manner that is not in consonance with applicable law or the standards set forth in DODD 2310.01E.
- Will not certify or participate in the certification of the fitness of detainees for any form of treatment or punishment that is not in consonance with applicable law or participate in any way in the administration of any such treatment or punishment.
- Will not participate in any procedure for applying physical restraints to the person of a detainee unless such a procedure is determined to be necessary for the protection of the physical or BH or the safety of the detainee or necessary for the protection of other detainees or those treating, guarding, or otherwise interacting with them. Such restraints, if used, shall be applied in a safe and professional manner.

4-157. Medical platoon personnel engaged in a professional provider-patient treatment relationship with detainees will not participate in detainee-related activities for purposes other than medical care. Such medical platoon personnel will not actively solicit information from detainees for other than medical purposes. Medical platoon personnel engaged in nontreatment activities (such as forensic psychology, behavioral science consultation, forensic pathology, or similar disciplines) will not engage in any

professional provider-patient treatment relationship with detainees (except in emergency circumstances in which no other medical providers can respond adequately to save life or prevent permanent impairment).

4-158. During the initial evaluation of detainees, any preexisting medical conditions, wounds, fractures, and bruises should be noted. Documentation of these injuries/conditions provides a baseline for each detainee that facilitates the identification of injuries which may have occurred in the theater detention facility.

4-159. Detainees, who report for routine sick call, should be visually examined to determine if any unusual or suspicious injuries are apparent. If present, the medical provider should determine from the detainee how the injuries occurred. Any injuries which cannot be explained or for which the detainee is providing evasive responses should be noted in the medical record and reported to the chain of command, technical medical channels, and United States Army Criminal Investigation Command.

4-160. Medical platoon personnel may enter the holding areas of the theater detention facility for a variety of reasons. These can include, but are not limited to, conducting sanitary inspections, providing EMT, and dispensing medications. When in the holding areas of the theater detention facility, medical care personnel must be observant. Should they observe anything suspicious which might indicate that detainees are being mistreated, they should report these suspicions immediately to the chain of command.

4-161. Should they observe a detainee being mistreated, they should take immediate action to stop the abuse and then report the incident.

4-162. Detained personnel must have access to the same standard of medical care as the United States and multinational forces to include respect for their dignity and privacy. In general, the security of detainees' medical records and confidentiality of medical information will be managed the same way as for the United States and multinational forces. During detainee operations, the patient administrator, the Criminal Investigation Division, the International Committee of the Red Cross, and medical chain of command can have access to detainee medical records besides the treating medical personnel. See figure 4-9 on page 4-52 for an example of how detainees are handled at the battalion level.

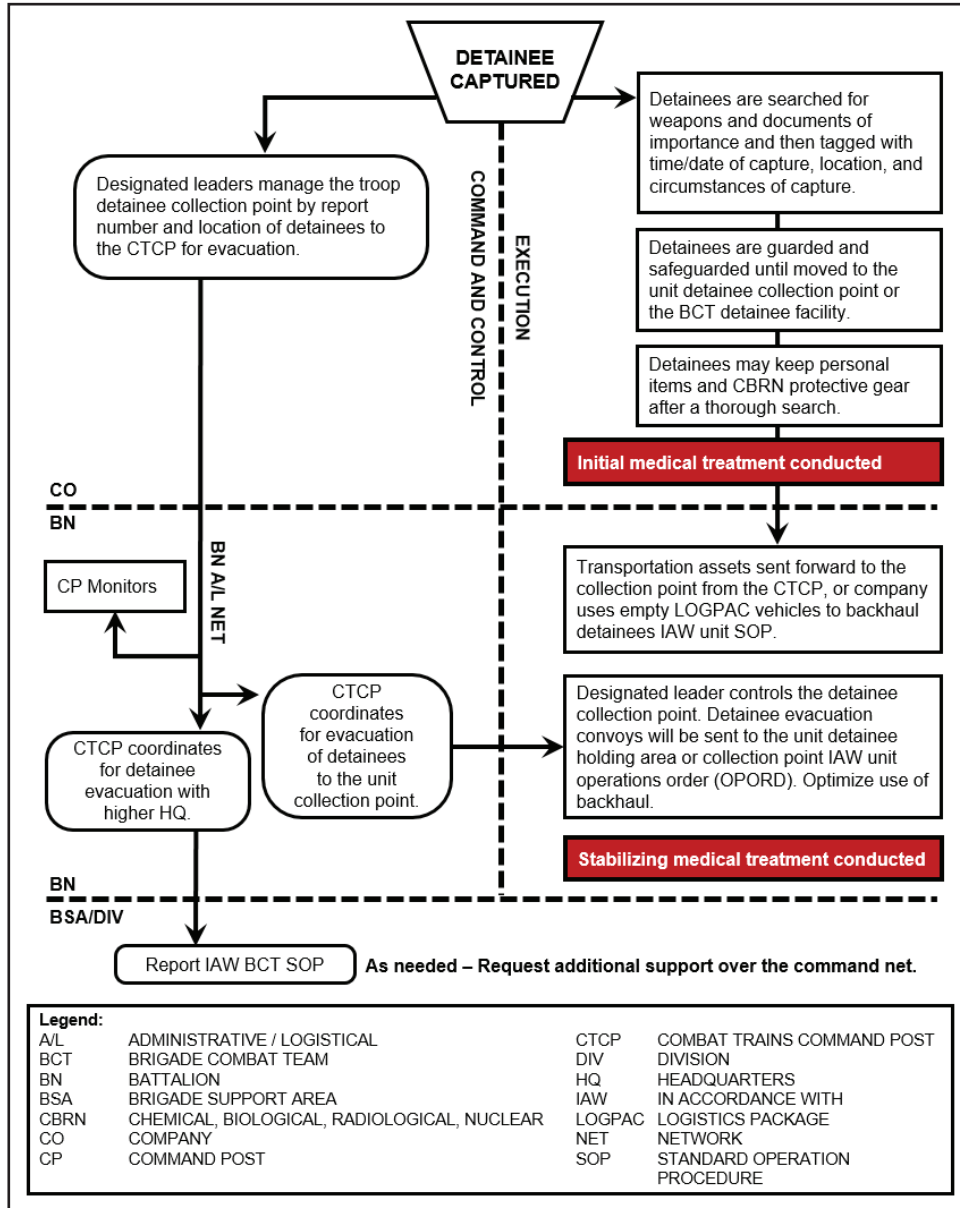

Figure 4-9. Detainee handling flow chart

Chapter 5

Chemical, Biological, Radiological, and Nuclear Operations

Chemical, Biological, Radiological, and Nuclear operations are the employment of capabilities that assess, protect against, and mitigate the entire range of CBRN incidents to enable freedom of action. Chemical, biological, radiological, and nuclear operations support operational and strategic objectives to counter weapons of mass destruction and operate safely in a CBRN environment. Many state and nonstate actors (including terrorists and criminals) possess or have the capability to possess, develop, or proliferate CBRN weapons. United States policy prohibits the use of chemical or biological weapons under any circumstances, but it reserves the right to employ nuclear weapons. Many potential enemies are under no such constraint. Refer to FM 3-11 and ATP 4-02.7/MCRP 3-40A.6/NTTP 4-02.7/AFTTP 3-42.3 for more information.

Contents		
SECTION I	Mission-Oriented Protective Posture	Page 5-1
SECTION II	Actions During and After an Attack	5-4
SECTION III	Unit Decontamination	5-9
SECTION IV	Role 1 HSS in a CBRN Environment	5-12
SECTION V	Role 1 Battalion Aid Station Decontamination	5-21
SECTION VI	Patient Decontamination	5-24
SECTION VII	Unmasking Procedures	5-73

SECTION I – MISSION-ORIENTED PROTECTIVE POSTURE

5-1. *Mission-oriented protective posture* is a flexible system of protection against CBRN contamination in which personnel are required to wear only that protective clothing and equipment appropriate to the threat level, work rate imposed by the mission, temperature, and humidity. Also called MOPP (JP 3-11).

MISSION-ORIENTED PROTECTIVE POSTURE

5-2. As MOPP levels increase, individual protective equipment (IPE) is added to the equipment worn at lower levels. Each increase in the MOPP level reduces the time personnel must take to attain MOPP 4 and full protection. When the threat of CBRN use is high, commanders may establish a standing MOPP level (other than MOPP-0) for personnel during military operations. In the event of a CBRN attack, this effectively reduces the time required to attain MOPP 4. In a CBRN incident medical platoon personnel will be required to don IPE. The medical platoon can use GTA 03-10-001 to see a list of CBRN IPE.

5-3. The protective suit and hood can cause body heat buildup, increasing the body's temperature by 15 degrees, which can lead to increased risk of heat injuries. The protective mask and hood degrade the ability to see, speak, and hear. The protective gloves restrict air circulation and limit the sense of touch and the ability to perform tasks requiring delicate manipulation. The wearing of full IPE or personal protective equipment can cause psychological stress (such as claustrophobia) in some people. All of these problems can reduce the effectiveness of HSS. Therefore, flexibility in adjusting the MOPP levels should be trained and exercised to meet mission requirements, environmental conditions, and the threat of CBRN exposure.

5-4. Medical platoon personnel will potentially be wearing IPE as they care for patients. Not all patients will be in MOPP gear. Without adequate IPE, patients may suffer greater exposure to CBRN threats and hazards. Medical platoon personnel should use available patient decontamination systems in conjunction with treatment to mitigate risk to providers. Additionally, medical platoon personnel can use tarps, plastic sheeting, wet weather gear, trash bags, and available sheltering to reduce the risk to patients, providers, and other personnel.

PROTECTIVE EQUIPMENT

5-5. Protecting Soldiers from the harmful hazards associated with CBRN attacks in an AO is essential to preserving combat power. Leaders determine the appropriate MOPP level based on higher-level guidance and the MOPP analysis provided by CBRN, intelligence, and medical platoon personnel. The CBRN MOPP analysis process takes into account METT-TC, estimating unit/personnel effectiveness (for example, mission degradation), estimating additional logistic requirements (for example, water resupply and IPE replenishment), and assessing and weighing the tradeoffs between agent exposures, degraded performance, and physical stress (for example, wearing of MOPP level 4).

5-6. Leader involvement is necessary to ensure safe and sustained operations under various climatic conditions. Leaders should develop standard responses and COAs for each projected mission, based upon the assessed CBRN threat. A sufficient response to a CBRN attack is incorporated into training to allow personnel to familiarize themselves with impacts to tasks and develop TTP to prevent degradation of medical care in MOPP conditions. Logistically, the first MOPP set should be worn or immediately available to medical platoon personnel. The second MOPP set should be managed by unit supply

sections and be available within six hours. The third set available at the SSA. It is vitally important that supply and CBRN personnel supporting medical platoon personnel ensure the correct sizes and amounts of IPE are available. A sufficient response to a CBRN attack is incorporated into training to allow personnel to familiarize themselves with impacts to tasks and develop TTPs to prevent degradation of medical care in MOPP conditions. The MOPP levels are described in table 5-1.

Table 5-1. Mission-oriented protective posture levels

<i>MOPP Level</i>	<i>Available for immediate donning</i>	<i>Available</i>
MOPP Ready	<ul style="list-style-type: none"> • Protective mask. 	<ul style="list-style-type: none"> • Carry protective mask with load-carrying equipment. • Store IPE at geographically close logistical site (< 2 hours).
MOPP Ready is used if the probability of CBRN threats exists; all Soldiers carry a protective mask and ensure that IPE is available within two hours.		
MOPP 0	<ul style="list-style-type: none"> • IPE. • Field gear. 	<ul style="list-style-type: none"> • IPE issued, serviceable, and within arms reach. • Protective mask filter/hood installed.
MOPP 0 is used during periods of increased alert when the adversary/enemy has CBRN employment capabilities, but there is no indication of use in the immediate area.		
<i>MOPP Level</i>	<i>Worn</i>	<i>Available</i>
MOPP 1	<ul style="list-style-type: none"> • Protective suit. • Field gear. 	<ul style="list-style-type: none"> • Protective boots. • Protective mask. • Protective gloves.
MOPP 1 is generally used when a CBRN attack in theater is possible. At this point, personnel should remove contact lenses, wear glasses, and make sure optical inserts are in their protective mask.		
MOPP 2	<ul style="list-style-type: none"> • Protective suit. • Field gear. • Protective boots. 	<ul style="list-style-type: none"> • Protective mask. • Protective gloves.
MOPP 2 is generally used when a CBRN attack in theater is likely.		
MOPP 3	<ul style="list-style-type: none"> • Protective suit. • Protective mask with hood secured. • Field gear. • Protective boots. 	<ul style="list-style-type: none"> • Protective gloves.
MOPP 3 is generally used in areas with a potential chemical agent threat where a chemical agent contact hazard does not exist.		

Table 5-1. Mission-oriented protective posture levels (continued)

<i>MOPP Level</i>	<i>Worn</i>	<i>Available</i>
MOPP 4	<ul style="list-style-type: none"> • Protective suit. • Protective mask with hood secured. • Field gear. • Protective boots. • Protective gloves. 	
MOPP 4 is used when the highest degree of CBRN protection is required or when CBRN agents are suspected or present but the actual hazard has not been determined.		
Legend:		
CBRN chemical, biological, radiological, nuclear		
IPE individual protective equipment		
MOPP mission-oriented protective posture		

5-7. Leaders know that they cannot expect the same work rates in MOPP Level 4 as they achieved in MOPP Level 0. They reevaluate the ability to meet mission requirements and communicate changes to the force. Mission-oriented protective posture reduction decisions are the most difficult to make because of the many considerations that affect the final decision. Commanders must evaluate the situation from the Soldier and mission perspectives. Factors include the criticality of the current mission, potential effects of personnel exposure, and the impact on the casualty care system. Army Techniques Publication 3-11.32/MCWP 10-10E.8/NTTP 3-11.37/AFTTP 3-2.46 provides work/rest cycles and water replacement guidelines for CBRN MOPP levels.

5-8. Leaders determine the appropriate MOPP level by assessing mission variables and weighing the impact of increased protection levels. Higher headquarters provide MOPP level directives to subordinate elements, and subordinate elements may increase but not decrease MOPP levels.

5-9. When a CBRN attack is recognized, everyone in the medical platoon must receive the warning and assume the appropriate MOPP level. Soldiers in immediate danger need warnings they can see or hear. The alarm or signal must be simple, unmistakable, and practiced if it is to produce a quick and correct reaction.

5-10. If a CBRN hazard is located, the platoon should mark the contaminated area. The CBRN warning and reporting system and standardized contamination markers contribute to orderly warning procedures. Warning methods include automatic alarms, vocal alarms (a shout of GAS is the most frequently used alarm), nonvocal alarms (horn blasts or banging of metal-to-metal objects), and visual alarms, most commonly used are the appropriate hand-and-arm signals. When possible, medical platoon personnel should protect potentially exposed Class VIII materials from CBRN contamination.

SECTION II – ACTIONS DURING AND AFTER AN ATTACK

5-11. If the platoon cannot avoid a CBRN hazard, it must be prepared to protect personal and equipment from the exposure. The key to effective protection in a CBRN

environment is the medical platoon's proficiency in automatically and correctly implementing CBRN defense and follow on decontamination and treatment SOPs. Suspected or known CBRN hazard exposures are documented in accordance with DODI 6490.03 and DODD 6490.02E in case acute, latent, and chronic term physical effects develop.

CHEMICAL DEFENSE

5-12. After the alarm is given have all unmasked Soldiers put on their protective masks and other MOPP gear. All personnel should move inside their vehicles or under cover; in most cases, they should close all doors and place their hatches in the closed position to protect against gross contamination. At this time, crews of vehicles that are equipped with CBRN over pressurization should turn the system on. Use unit level chemical agent detectors to determine the type of agent, and forward a CBRN-1 chemical report. Continue the mission.

5-13. Tactical and safety considerations (such as observation of the terrain, enemy disposition, and how much gross contamination that may be spread inside the vehicle) may outweigh the need to keep the vehicle doors or hatches closed. Depending on the tactical situation and unit SOP, platoon members may need to keep their doors and hatches in the open or open-protected position.

BIOLOGICAL DEFENSE

5-14. The medical platoon may be the first unit to recognize a biological attack has occurred due to an increase in patients presenting with similar signs and symptoms from a certain unit or supported AO or receiving reports of sick or dead animals in a certain area. Many biological warfare agents cause flu like or food poisoning signs and symptoms that the medical platoon should be aware of. This may also be an endemic or emerging disease in that AO. Determining if the disease is naturally occurring or from a biological attack may alter the treatment protocols and require evacuation to a higher role of care.

5-15. After a biological attack, platoon members must assume that all surfaces have been exposed to biological hazards and must be decontaminated appropriately. Do not eat food or drink water that may be contaminated. Eat or drink only food or water that has been stored in tightly sealed containers; consume it only after washing and cleaning the outside of the container as outlined in ATP 4-02.7/MCRP 3-40A.6/NTTP 4-02.7/AFTTP 3-42.3. All water must be boiled for at least 15 minutes.

NUCLEAR DEFENSE

5-16. This discussion focuses on defensive measures the platoon must be prepared to take to protect platoon members and patients, whether they are in their vehicle or have dismounted during a nuclear attack.

MOUNTED DEFENSIVE ACTIONS

5-17. If time permits, the platoon should take the following actions:

- Position each vehicle behind the best available cover with the front of the vehicle toward the blast.
- Lock the brakes.
- Secure loose equipment inside the vehicle to prevent injuries and equipment damage.
- Secure all exterior components that could be damaged by the blast (such as water cans, duffel bags, and antennas) inside the vehicle.
- Turn off all radios as well as master power.
- Close and lock all doors and hatches, including ballistic shields.
- Take actions to protect the head and eyes. As necessary, wear helmets and eye protection whenever possible.

DISMOUNTED DEFENSIVE ACTIONS

5-18. When faced with a nuclear blast Soldiers should tightly close their eyes and immediately drop flat on the ground (face down) or to the bottom of a fighting position, facing away from the fireball, never run for cover. They should cover as much exposed skin as possible and remain down until the blast wave has passed and debris has stopped falling. And finally they should stay calm, check for injury, check weapons and equipment for damage, and prepare to continue the mission.

DEFENSE AFTER A NUCLEAR ATTACK

5-19. Once the attack has ended, forward a CBRN-1 nuclear report, organize survivors, secure and organize equipment, repair and reinforce fighting positions and casualty trenches, treat patients, improve protection against possible fallout, and begin continuous monitoring. Leaders should ensure employment of dosimeters to track dose rates and total accumulated radiation dosage. Total dose should be recorded by the higher headquarters to determine risk to forces, tactical repositioning, or increased shielding requirements. Based on higher headquarters guidance, if the radiation dose rate reaches a hazardous level after fallout has ended be prepared to move, on order, to a less hazardous area.

5-20. When operating in or crossing radiologically contaminated areas, vehicles should be closed tightly. Crewmen wear their protective masks to prevent inhalation of radiological particles; cargoes should be covered by tarps or tenting. Mission permitting, vehicles should keep their speed down to prevent dust and should maintain adequate following distance to stay out of the dust raised by preceding vehicles. After the unit exits a contaminated area, personnel, equipment, and cargo should be checked for contamination and decontaminated, if necessary.

5-21. At a minimum, each crew should monitor their total accumulated dose using the unit's organic radiological detection equipment. Total dose and dose rates should be monitored closely as Soldiers operate and be reported to the company to maintain compliance with operational exposure guidance and provide medical tracking of Soldier radiation exposure. The medical platoon can utilize GTA 03-10-002 for a list of small-unit CBRN detection equipment.

MARKING CONTAMINATED AREAS

5-22. Contamination must be marked so unsuspecting personnel will not be exposed to it. When the medical platoon detects or suspects a CBRN hazard, they mark all likely entry points into the area and report the contamination to higher headquarters.

TYPES OF MARKERS

5-23. United States forces use North Atlantic Treaty Organization (NATO) standard markers to make it easier for allies to recognize the hazards. These markers are in the standard CBRN marking set. The colors and inscriptions on a marker indicate the type of hazard. Additional information is written on the front of the sign (see table 5-2).

MARKING PROCEDURES

5-24. Markers face away from the contamination. For example, if markers are placed on the edge of a contaminated area to mark a radiological hot spot, they face away from the point of the highest contamination reading. Markers are placed along roads and trails and at other likely points of entry. When time and mission permit, additional markers should be emplaced. The distance between signs varies. In open terrain, they can be placed 25 to 100 meters (80-325 feet) apart; in hilly or wooded areas, they should be placed more frequently. An observer should be able to stand in front of a marker and see the markers to the left and right of it.

5-25. Units discovering a marked contaminated area do not have to conduct elaborate, time-consuming surveys. They simply check the extent of contamination and use the information to adjust their plans, if necessary. If the size of the hazard has changed, they relocate the signs. If the hazard is gone, they remove the signs. Changes are reported to higher headquarters.

Table 5-2. Chemical, biological, radiological, and nuclear markers

<i>Symbol or sign</i>	<i>Definition</i>
<p>The diagram illustrates the components of a CBRN marker sign. It features a triangular sign with a 'C' and 'T' at the top and an 'N' in the center. The sign is annotated with various fields: 'Date-time group' (291000ZFEB08), 'Type' (B61), 'Unique designation' (BOMB), 'Quantity indicator' (1), 'Direction of movement indicator' (JK01041973), and 'Location' (ENY).</p>	<p>CBRN contaminated area or CBRN event. This symbol can be placed on the map in conjunction with a shape to mark the contaminated area. The "T" can be added to indicate toxic industrial material. The CBRN event is a graphic control measure for marking CBRN hazard areas. Other information may be added according to FM 1-02.2 or MIL-STD 2525D.</p> <ul style="list-style-type: none"> • C—chemical • B—biological • R—radiological • N—nuclear

Table 5-2. Chemical, biological, radiological, and nuclear markers (continued)

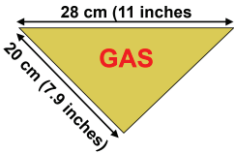
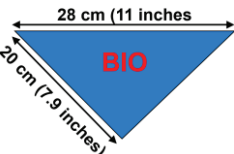
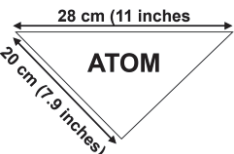
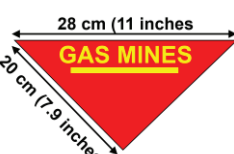
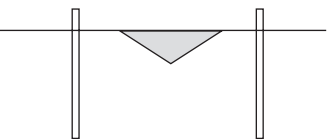
<i>Symbol or sign</i>	<i>Definition</i>
	Yellow background with red lettering <ul style="list-style-type: none"> • Name of agent (if known) • Date and time of detection • Date and time of detonation/release (if known) • Concentration (if known)
	Blue background with red lettering <ul style="list-style-type: none"> • Name of agent, if known • Date and time of detection • Date and time of detonation/release (if known) • Concentration (if known)
	White background with black lettering <ul style="list-style-type: none"> • Dose rate • Date and time of reading • Date and time of detonation/release (if known)
	Red background with yellow lettering and stripe <ul style="list-style-type: none"> • Chemical agent in mine • Date • Surface of marker facing away from minefield
	The perimeter of a contaminated area should be marked by a fence placed on all probable routes leading into the contaminated area at about 20 meters (66 feet) before the point where the presence of contamination was detected. Ten to 50 meters may be between signs based on the terrain. In the case of toxic industrial chemicals, mark the boundaries of the exclusion or isolation zones (see TM 3-11.91/MCRP 10-10E.5/NTRP 3-11.32/AFTTP 3-2.55). Warning signs may be attached waist high to a fence or using the M274 marking.
Legend: ADP Army Doctrine Publication CM centimeter MIL-STD military-standard	

SECTION III – UNIT DECONTAMINATION

5-26. *Decontamination* is the process of making any person, object, or area safe by absorbing, destroying, neutralizing, making harmless, or removing chemical or biological agents, or by removing radioactive material clinging to or around it. (JP 3-11). During continuous operations in areas of contamination, decontamination is essential in preventing casualties and severe combat degradation. The medical platoon gains maximum benefit from the available time and decontamination resources by observing these considerations:

- Decontamination should be as soon as possible and as far forward as possible.
- Decontamination should be conducted only to the extent necessary to ensure the platoon's safety and operational readiness.
- Decontamination priorities with regard to unit safety and mission accomplishment should be strictly observed.

5-27. These principles are consistent with doctrine that places the burden of decontamination at battalion or company level. For this reason, the medical platoon must develop a thorough SOP covering decontamination methods and priorities, using all available assets to the maximum extent possible. Refer to ATP 3-11.32/ MCWP 10-10E.8/NTTP 3-11.37/AFTTP 3-2.46 for a more detailed examination of CBRN decontamination procedures.

5-28. The levels of decontamination used for patients are similar to those levels used for the decontamination of personnel and equipment (See table 5-3 on page 5-11). There are three levels of decontamination used during decontamination operations for patients as follows:

- *Immediate decontamination*—decontamination carried out by individuals immediately upon becoming contaminated to save lives, minimize casualties, and limit the spread of contamination (JP 3-11).
- *Operational decontamination*—decontamination carried out by an individual and/or a unit, restricted to specific parts of operationally essential equipment, materiel and/or working areas, in order to minimize contact and transfer hazards and to sustain operations (JP 3-11).
- *Thorough decontamination*—decontamination carried out by a unit to reduce contamination on personnel, equipment, materiel and/or working areas equal to natural background or to the lowest possible levels, to permit the partial or total removal of IPE and to maintain operations with minimum degradation (JP 3-11).

IMMEDIATE DECONTAMINATION

5-29. Immediate decontamination minimizes casualties and limits the spread or transfer of contamination. This action is carried out by the contaminated individual and the purpose is to save lives and reduce penetration of agent into surfaces. This may include decontamination of personnel, clothing, and equipment. Immediate decontamination

should help prevent casualties and permit the use of individual equipment and key systems.

5-30. Patient decontamination begins at the time of exposure. To significantly reduce agent absorption and the damaging effects of an agent, decontamination should be performed before one minute after exposure, though later decontamination still has benefits. Decontamination also reduces the possibility of cross contamination from the exposed Soldier's garments to equipment or other persons. The contaminated Soldier performs immediate personal decontamination using the appropriate decontaminant. Contaminated areas on the protective ensemble and exposed intact skin are decontaminated. If the Soldiers are not able to decontaminate themselves due to injury or incapacitation then a buddy performs this function.

OPERATIONAL DECONTAMINATION

5-31. Operational decontamination allows a force to continue fighting and sustain momentum after being contaminated and eliminates or reduces the duration that MOPP equipment should be used. It limits the hazard of transferring contamination by removing most of the gross contamination on equipment and nearly all the contamination on individuals.

5-32. Operational decontamination is carried out by the contaminated unit (with possible assistance from an organic decontamination organization). Operational decontamination is restricted to the specific parts of contaminated, operationally essential equipment, material, and work areas to minimize contact and transfer hazards and to sustain operations.

5-33. Contamination will accumulate and be encapsulated in dirt on tires, rims, between sprockets, road wheels, and in between tracks. The air system of vehicles may also be contaminated and may require replacement parts to prevent restricted or blocked air flow into the engine.

5-34. Operational decontamination is performed at the unit level to reduce contamination on designated in-theater evacuation assets. It is done prior to loading the patient on a vehicle for evacuation within the tactical area. The patient remains in protective ensemble and mask. Any liquid or solid hazard on the ensemble and skin are decontaminated to minimize the spread of contamination within the evacuation vehicle.

THOROUGH DECONTAMINATION

5-35. Thorough decontamination is conducted by the unit to reduce contamination on personnel, equipment, materiel and/or working areas to the lowest possible levels, to maintain operations with minimum degradation

5-36. In regards to patient decontamination, this is the final level. It generally involves at least removal of all outer garments and removal of residual agents on skin or in hair. See ATP 4-02.7/MCRP 3-40A.6/NTTP 4-02.7/AFTTP 3-42.3. While it is critical to prevent exposure to medical staff, excessive decontamination procedures should be avoided to prevent delays to medical treatment. This process ensures that the patient

has been properly decontaminated and all necessary records regarding decontamination, monitoring results, type and duration of exposure and location of incident are properly recorded to facilitate future medical surveillance and ensure the safety of all personnel after the patient's release or transfer to a medical facility location outside the CBRN environment. Nonmedical augmentees who are closely supervised by medical platoon personnel perform this level of decontamination.

Table 5-3. Decontamination levels

Levels	Purpose	Tasks¹	Best start time	Performed by
Immediate	<ul style="list-style-type: none"> • Saves lives • Stops agent from penetrating • Limits agent spread 	Skin decontamination	Before 1 minute	Individual
		Personal wipe down	Within 15 minutes	Individual or buddy
		Operator wipe down	Within 15 minutes	Individual or crew
		Spot decontamination	Within 15 minutes	Individual or crew
Operational	<ul style="list-style-type: none"> • Continues operations in a contaminated environment • Limits agent spread 	MOPP gear exchange CCS and/or CCA	Within 6 hours ²	Contaminated unit
		Vehicle wash down	Within 6 hours	Battalion/company/platoon/crew/team/ or decontamination unit
Thorough	<ul style="list-style-type: none"> • Provides probability of long-term MOPP reduction 	DED/DAD and/or DTD	When mission allows reconstitution	Decontamination unit/personnel or contaminated unit, as applicable
<p>¹These tasks become less effective the longer they are delayed. ²Performance degradation, equipment limitation and a health risk assessment must be considered when exceeding six hours. (See TM 3-11.42/MCTP 10-10G/NTTP 3-11.36/AFTTP 3-2.82.)</p> <p>Legend: CCA contamination control area CCS contamination control station DAD detailed aircraft decontamination DED detailed equipment decontamination DTD detailed troop decontamination MOPP mission-oriented protective posture</p>				

SECTION IV – ROLE 1 HEALTH SERVICE SUPPORT IN A CHEMICAL, BIOLOGICAL, RADIOLOGICAL, AND NUCLEAR ENVIRONMENT

5-37. When operating under a CBRN threat or when a CBRN attack is imminent, the medical platoon must prepare for continuation of its mission. If an attack occurs, the platoon must seek out a contamination-free area to establish a clean treatment area or must be collectively protected. The Role 1 BAS (minus the CAB) have chemical-biological protective shelter (CBPS) systems. When available, these systems serve as the primary shelter for the BAS; they are operated in the full chemical-biological (CB) mode when attack is imminent or has occurred. See ATP 4-02.7/MCRP 3-40A.6/NTTP 4-02.7/AFTTP 3-42.3, chapter 12 for more information on establishing a BAS in a CBPS system. When operating in the CB mode, only patients requiring life- or limb-saving procedures are allowed entry into the BAS. Patients who have minor injuries that can be managed in the contaminated EMT area of the PDS will receive treatment in this area. Patients with injuries that require further treatment but can survive evacuation to the Role 2 BSMC will have their MOPP immediately decontaminated, their injuries managed, the integrity of their MOPP restored, and be directed to an evacuation point to await transport to the Role 2 BSMC. When patients or personnel are contaminated or are potentially contaminated, they must be decontaminated before admission into the clean treatment area (see ATP 3-11.32/MCWP 10-10E.8/NTTP 3-11.37/AFTTP 3-2.46 for individual and equipment decontamination procedures and ATP 4-02.7/MCRP 3-40A.6/NTTP 4-02.7/AFTTP 3-42.3, chapter 5 for patient decontamination procedures).

5-38. The medical platoon selects sites for the Role 1 BAS that are located away from likely adversary target areas. Cover and concealment are extremely important; they increase protection for operating the BAS. The site selected is uphill, upwind, and upstream of any CBRN contamination.

5-39. Operating a CBPS system in the CB mode at the BAS requires at least eight medical platoon personnel. The senior medical platoon personnel/NCO performs patient triage, limited EMT, and minor injury care in the PDS. One member of medical platoon supervises patient decontamination and manages patients during the decontamination process. Two medical platoon personnel work on the clean side of the hot line and manage the patients until they are placed in the clean treatment area or are sent into the CBPS for treatment. They also manage the patients that are awaiting evacuation to the Role 2 BSMC. The field surgeon, PA, and two combat medics provide advanced medical treatment in the clean treatment area or inside the CBPS. See ATP 4-02.7/MCRP 3-40A.6/NTTP 4-02.7/AFTTP 3-42.3, chapter 12 for CBPS entry/exit procedures.

5-40. When the BAS receives CBRN contaminated patients, they require at least eight nonmedical augmentees from supported units to perform patient decontamination procedures under medical supervision. The BAS is only staffed with medical platoon personnel to provide patient care under conventional operational conditions. Without the augmentation support, they can either provide patient decontamination or patient care, but not both.

OPERATION OF A ROLE 1 BATTALION AID STATION IN A CHEMICAL ENVIRONMENT

5-41. Initial triage, EMT, and decontamination are accomplished on the dirty side of the hot line of the PDS. Life-sustaining care is rendered, as required, without regard to contamination. Normally, the senior medical platoon personnel perform initial triage and EMT. Secondary triage, advanced medical treatment, and patient disposition are accomplished on the clean side of the hot line. When treatment must be provided in a contaminated environment outside the collectively protected shelter (CPS), the level of care may be greatly reduced because medical platoon personnel and patients are in MOPP Level 4. However, lifesaving procedures must be accomplished. See ATP 4-02.85/MCRP 3-40A.1/NTRP 4-02.22/AFTTP (I) 3-2.69 and the United States Army Medical Research Institute of Chemical Defense *Medical Management of Chemical Casualties Handbook* or the United States Army Medical Research Institute of Chemical Defenses website for specific guidance and understanding of the chemical threats faced by personnel in a CBRN environment, effective medical defenses against these threats, and patient treatment procedures.

5-42. Decontamination of most chemically contaminated equipment requires the use of materials that will remove and neutralize the agent. See ATP 3-11.32/MCWP 10-10E.8/NTTP 3-11.37/AFTTP 3-2.46 for military equipment decontamination procedures.

WARNING

Cross contamination of patients during decontamination can result in further injury to the patient. Personnel decontaminating patients must handle patients carefully to prevent themselves from becoming contaminated.

INDIVIDUAL PROTECTION

5-43. When CBPS systems are not available, using the correct MOPP level is essential in Role 1 BAS mission performance. The level of MOPP assumed depends upon the level of threat. An alternative approach for the BAS is the use of the mask-only posture. This posture is acceptable when the hazard is from vapor only (such as no persistent agents). Patients and personnel in tents and expandable shelters are protected for a limited time from solid or liquid contamination (transfer hazards). Personnel can work efficiently and for longer periods in mask-only posture instead of MOPP Level 4. However, platoon leadership must weigh these factors against the potential contamination transfer risk. This risk should be small, except in areas where patients or materiel are received from the outside. Individuals returning to or bringing materiel from the outside must be extremely careful not to bring contamination into the mask-only area. When considering this alternative, remember that except for those patients in

a chemical patient protective wrap (CPPW), the patients must also be at mask-only posture.

5-44. The BAS must ensure they have an adequate supply of new replacement filters on hand for patients as well as platoon members. Patients who have gone through decontamination will need to have their filters replaced immediately after decontamination. Decontamination team members will need to have their filters replaced periodically (for example, between each shift or when filters get wet) according to unit SOP. The BAS personnel should plan for the safe storage and disposal of patient and medical platoon member's contaminated respirator filters.

5-45. The BAS should utilize a warning system that alerts all personnel of impending or present hazards. This system must include visual and auditory signals; the signals must operate inside and outside the immediate area of the BAS. There are numerous problems associated with warning personnel; they include:

- The wide area covered by the BAS.
- Some shift personnel will be asleep at all times of the day or night.
- Noise from the power generation and environmental control equipment.
- Tentage and equipment, which interrupts the line of sight.

5-46. When the CBRN alarm is activated, all personnel (including off duty personnel) report to their duty stations as soon as they are in MOPP Level 4. This allows for 100 percent personnel accountability and provides additional personnel to secure casualties and materiel.

5-47. With all openings secured and the ventilation system turned off, the noncollectively protected BAS is at its best posture. For nonpersistent agents (vapor hazards), personnel and patients stay at the designated MOPP level until the all clear signal is given; then normal operations are resumed.

Note. Decontaminated patients with injuries that prevent them from assuming a protective posture equal to Role 1 BAS personnel should be evacuated immediately to a clean treatment facility.

PATIENT PROTECTION

5-48. Patient protection depends on ensuring patients have adequate individual protection. Each patient's protective mask must be available and serviceable. The Role 1 BAS personnel should check all patients' masks as soon as they arrive. If the patient came from a contaminated area, the mask must be decontaminated and the filter changed. The mask decontamination and filter change may have to be performed by medical platoon personnel. If patients' medical conditions permit, they may be able to perform this task. Medical platoon personnel should not wait until the warning has been received to begin checking the masks. Each area must have an established plan for operations (to include assisting patients assuming MOPP or other protective posture) in the CBRN environment.

5-49. Battalion aid station personnel always mask themselves first and then assist patients in masking. Most routine patients can put on their own masks. For those who cannot, other patients can assist them after putting on their own masks.

5-50. Many patients with head and neck wounds or who are on life-support devices will be unable to wear their individual protective masks; these patients must be placed in CPPWs with blowers. While the CPPWs have two ports for intravenous (IV) or blood infusion lines, the staff may have to adapt for other devices (for example, catheters or traction) by using tape and other means to seal the gaps created in the seal around the edge of the CPPW. Patients requiring assisted ventilation are at extreme risk, unless their air supply is protected.

MATERIEL PROTECTION

5-51. Protection of materiel, especially expendable medical supplies, requires covers and barriers. All materiel not required for immediate use is kept in shipping containers, medical chests, or under cover (such as tentage, plastic sheeting, or tarpaulin) for protection against particulate or liquid hazard. Protection against vapor hazards may require multiple barriers through which the vapor must penetrate. For example, a situation where IV solutions are in their individual plastic bags, in the cardboard shipping box, on a covered pallet, and in a vehicle's covered cargo compartment. This represents four barriers against the vapor hazard. These principles should be used to the maximum extent practical.

ENVIRONMENTAL PROTECTION

5-52. As noted previously, the Role 1 BAS offers some protection against liquid or fallout contamination but little protection against vapor hazards.

5-53. When MOPP Level 2 posture must be assumed, close and secure all tent flaps, vents, and doors to prevent the entrance of liquids or particles. All medical platoon personnel outside of shelters assume command-directed MOPP level. Cover or move all equipment and supplies into shelters if possible. Keep all equipment and supplies not immediately needed covered or in closed containers.

5-54. When MOPP Level 3 or mask-only posture is assumed, shutdown the BAS ventilation system if in a nonchemically protected facility to prevent drawing vapors into the BAS. This measure provides some protection of the internal environment during the time required for the vapor to penetrate the tentage. For chemically protected facilities, keep the ventilation on to maintain positive airflow.

OPERATION OF A ROLE 1 BATTALION AID STATION IN A BIOLOGICAL ENVIRONMENT

5-55. A biological agent attack (such as the adversary use of bomblets, rockets, spray or aerosol dispersal, release of arthropod vectors, and adversary or insurgent contamination of food and water) may be difficult to recognize. Airborne dissemination is a likely means of delivery of biological agents. While such biological agents may produce large numbers of casualties, initial patients may be seen at the Role 1 BAS in

small numbers. When a trend is identified, the use of a biological warfare agent may be suspected.

5-56. Frequently, biological warfare agent exposure does not have an immediate effect on exposed personnel. All HSS personnel must monitor for biological warfare agent indicators such as:

- Increases in disease incidence or fatality rates.
- Sudden presentation of an exotic disease.
- Other sequential epidemiological events such as large numbers of sick or dead animals in the area.

5-57. Biological agent attack protective measures are the same as the measures for chemical warfare agents when bombs, sprays, or aerosols are used. General protective measures are the same as for any infectious disease; specific protective measures are used once the method of transmission has been identified. The difficulty in rapidly identifying biological agents may force the use of higher levels of MOPP for longer periods of time. Faced with this situation, a careful evaluation of the mask-only posture is necessary before implementing any level of MOPP.

5-58. Passive defensive measures (such as immunizations, good personal hygiene, physical conditioning, using insect repellents, wearing the protective mask, and practicing good sanitation) will mitigate the effects of many biological warfare agent intrusions.

5-59. Designating a single role of care medical unit to care for these patients (from a casualty care or disease transmission standpoint) may not be necessary. However, if there are a limited number of cases, consolidating them all at one facility maximizes the use of limited diagnostic laboratory and personnel assets. Quarantine of exposed personnel or isolation of casualties may be warranted in some cases, particularly with infectious biological agent exposure. If these situations exist (although this only applies to a small number of biological threats), then quarantine and isolation procedures should be followed. Restriction of movement and social distance may also be used to prevent or slow down the spread of infectious diseases. A list of contagious diseases is listed in ATP 4-02.7/MCRP 3-40A.6/NTTP 4-02.7/AFTTP 3-42.3, chapter 4.

5-60. Medical commanders and leaders must enforce contamination control to prevent illness or injury to HSS personnel and to preserve the BAS. Incoming vehicles, personnel, and patients must be surveyed for contamination. Ventilation systems in an BAS without CPS must be turned off if biological warfare agent exposure is imminent.

5-61. Decontamination of most biological warfare agent patients and equipment can be accomplished with soap and water. Soap and water will not kill all biological agents; however, it will remove the agent from the skin or equipment surface. See ATP 4-02.7/MCRP 3-40A.6/NTTP 4-02.7/AFTTP 3-42.3, chapter 5 for specific patient decontamination procedures and ATP 3-11.32/MCWP 10-10E.8/NTTP 3-11.37/AFTTP 3-2.46 for specific equipment decontamination procedures.

5-62. Treatment of biological warfare agent patients may require observing and evaluating the individual to determine necessary medications, isolation requirements, or

medical management procedures. See ATP 4-02.84/MCRP 3-40A.3/NTRP 4-02.23/AFMAN 466 44-156 IP, and the *United States Army Medical Research Institute of Infectious Diseases, Medical Management of Biological Casualties Handbook* or United States Army Medical Research Institute of Infectious Diseases' website for specific guidance and understanding of the biological threats faced by personnel in a CBRN environment, effective medical defenses against these threats, and patient treatment procedures.

5-63. *Medical surveillance* is the ongoing, systematic collection, analysis, and interpretation of data derived from instances of medical care or medical evaluation, and the reporting of population-based information for characterizing and countering threats to a population's health, well-being, and performance. (JP 4-02). Medical surveillance is essential. Most biological agent patients initially present with common nonspecific symptoms such as low-grade fever, chills, headache, malaise, and coughing. A higher rate of patients than normal based on the number and location of personnel, known disease vectors, and endemic diseases may be the first, best, or only indication of biological agent attack. Daily medical treatment summaries, especially DNBI reports, need to be prepared and analyzed. A significant but unexplained or unpredictable increase in the rate of patients presenting with unusual or the same symptoms may indicate a disease outbreaks or the employment of biological agents. Since presenting symptoms can take days or more to manifest depending on the incubation period for a particular pathogen, daily analysis of medical summaries provide a delayed or lagging indicator of possible biological agent use. This means that the use of a biological agent may have happened several days before it is recognized and depending on operations, several hundreds of miles away. However, using medical, intelligence, and CBRN recommendations, commanders can initiate preventive, treatment, and mitigating measures and reduce the total numbers of personnel lost due to the illness and the impact of the mission. See DODD 6490.02E and DODI 6490.03 for information on health surveillance (medical surveillance and occupational and environmental health surveillance) procedures and required documentation of suspected or known CBRN hazard exposures.

OPERATION OF A ROLE 1 BATTALION AID STATION IN A NUCLEAR ENVIRONMENT

5-64. The HSS mission must continue in a nuclear environment. The CBPS is essential in continuing the support role. Well-constructed shelters with overhead cover and expedient shelters (reinforced concrete structures, basements, railroad tunnels, or trenches) provide good protection from nuclear attacks.

5-65. Most protective measures against nuclear attack require engineer and/or intensive logistics support. This support includes placing sandbag walls around tents, digging trenches for patient occupation, or constructing earthen berms. Occupying existing structures, depending upon their strength and potential flammability, may be the best protection against the effects of a nuclear strike. Leaving equipment packed and loaded until actually needed for operations will help protect materiel in a CBRN environment.

5-66. Personnel and patient protection requirements will depend upon the threat. If the threat is nuclear fallout, the Role 1 BAS tentage provides some protection; the fallout can be brushed or washed off. This allows protection while permitting patient care to continue virtually uninterrupted. A need to relocate the BAS will depend upon the degree of radiological contamination, the amount of decontamination possible, and the projected stay before a normal move in support of tactical operations. A nuclear attack can result in several types of injuries that medical platoon personnel must be aware of. Discusses below are several:

- Primary blast injury is caused by the blast wave itself.
- Secondary blast injury is caused by fragments of debris propelled by the explosion.
- Tertiary blast injury is due to the acceleration of the body or part of the body by the blast wave or blast wind.
- Thermal burns will be the most common injuries subsequent to both the thermal pulse and the fires it ignites. Flash (thermal pulse) burns, flame burns (from ignited clothing), and eye injuries (flash blindness and retinal burns) are possible as a result of a nuclear detonation.
- Nuclear attacks or radiological accidents can result in varying levels of injuries including acute radiation syndrome, acute local radiation injury, combined injuries (radiation, thermal, or blast injuries), psychological consequences, and may have chronic or latent health effects. Patients with combined injuries have a poorer prognosis than radiation only or trauma or burn only patients.

5-67. The BAS tentage alone offers little protection against blast and shrapnel effects. If the patients are to remain in the tents, they are placed on the floor. Place all equipment on the ground or as low as possible and secure all loose objects. In tents, sandbags can be piled around the base of the tent poles to add stability. The tent poles and casualties cots/beds should keep the canvas off the ground enough (if the tent collapses) to continue minimal casualty care.

5-68. See ATP 4-02.83/MCRP 3-40A.2/NTRP 4-02.21/AFMAN 44-161(I) for radiological/nuclear casualties and the *Armed Forces Radiobiology Research Institute (AFRRI) Medical Management of Radiological Casualties Handbook* <https://www.usuhs.edu/afri> for specific guidance and understanding of the radiological and nuclear threats faced by personnel in a CBRN environment, effective medical defenses against these threats, and patient treatment procedures.

5-69. Armored vehicles provide some protection against the blast and radiation effects of nuclear weapons. Patients generated in a nuclear attack will likely suffer multiple injuries (combination of blast, thermal, and radiation injuries) that will complicate medical care. Nuclear radiation patients fall into three categories:

- The irradiated patient is one who has been exposed to ionizing radiation but is not contaminated. They are not radioactive and pose no radiation threat to medical providers. Patients who have suffered exposure to initial nuclear radiation will fall into this category.

- The externally contaminated patient has radioactive dust and debris on their clothing, skin, or hair. This radioactive debris can cause burns if not removed quickly. This usually presents a problem to the aid station, similar to a lice-infested patient arriving at a peacetime BAS. However, an accumulation of radioactive debris from several patients admitted to the BAS may present a threat to other personnel. The externally contaminated patient is decontaminated at the earliest time consistent with required medical care. Lifesaving care is always rendered, when necessary, before decontamination.
- The internally contaminated patient is one that has ingested or inhaled radioactive material or radioactive material has entered the body through an open wound. The radioactive material continues to irradiate the patient internally until radioactive decay and/or biological elimination removes the radioactive isotope. Attending medical platoon personnel are shielded, to some degree, by the patient's body. Inhalation, ingestion, or injection of radioactive material sufficient to present a threat to medical providers is highly unlikely. Urine and feces from these patients may need to be collected, handled, and disposed of as radioactive hazardous material as the body eliminates the radioactive isotope.

5-70. The medical platoon operating in a radiation fallout environment will face three problems:

- The BAS may be immersed in fallout, requiring decontamination and relocation efforts.
- Patients may continue to be produced from continued radiation exposure.
- The contaminated environment hinders MEDEVAC operations.

5-71. Decontamination of most radiologically contaminated patients and equipment can be accomplished by removing the outer layer of clothing or with soap and water. Soap and water will not neutralize radioactive material however, it will remove the material from the skin, hair, or material surface. The waste can become a concentrated point of radiation and requires coordination with CBRN personnel and the supporting engineer unit for disposal. One way to mitigate waste is to coordinate with the CBRN officer and the supporting engineer unit to construct containment areas for the contaminated wastewater and other radioactive contaminated materials, such as clothing and biomedical waste.

MEDICAL EVACUATION IN A CHEMICAL, BIOLOGICAL, RADIOLOGICAL, AND NUCLEAR ENVIRONMENT

5-72. A CBRN environment forces unit leadership to consider to what extent they will commit MEDEVAC assets to the contaminated area. If the unit is operating in a contaminated area, most of or the entire number of organic MEDEVAC assets will operate there. However, efforts should be made to keep some ambulances free of contamination. For conventional patient movement operations see JP 4-02 and ATP 4-02.2.

5-73. Once the use of CBRN weapons has been confirmed and areas of contamination identified, subordinate commanders must decide the extent to which they will commit MEDEVAC assets not already contaminated during the attack. Depending on the situation, there may already be adequate numbers of vehicles, watercraft, and aircraft operating within the affected areas to transport the number of patients sustained. Full use of these assets should be made while keeping the safety and operational exposure of the personnel operating them in mind. These platforms (if not otherwise damaged) can respond relatively quickly to transport the wounded to designated areas where they can undergo patient decontamination and receive medical treatment.

5-74. In LSCO, land forces have three basic modes of evacuating patients: personnel (litter bearers), ground vehicles, and aircraft.

5-75. Using litter bearers to carry the patients involves a great deal of physical, mental, and emotional stress. Wearing cumbersome MOPP gear, combined with adverse climate conditions, harsh terrain, increased workload, and the fatigue of battle will greatly reduce personnel effectiveness. If personnel must enter a radiologically contaminated area, an operational exposure guide must be established. Once a unit or individual is exposed to radiation, exposure records are maintained by the battalion CBRN officer/NCO and made available to the commander, staff, and battalion surgeon. The exposure is also entered into the individual's medical and/or dosimetry record by medical platoon personnel. Based on the operational exposure guide, the commander and leaders will decide which MEDEVAC assets will be sent into the contaminated area.

5-76. Every effort is made to limit the number of ground evacuation assets that are contaminated. Patient movement considerations include:

- A number of ambulances will become contaminated in the course of battle. Optimize the use of resources; use those already contaminated (MEDEVAC or CASEVAC) before employing uncontaminated resources.
- Use ground ambulances instead of air ambulances in contaminated areas; they are more plentiful, are easier to decontaminate, and are easier to replace.
- Use ground vehicles to cross the line separating clean and contaminated areas.

5-77. The ground ambulance proceeds to a Role 1 BAS with a PDS; the patient is decontaminated and treated. If further evacuation is required, a clean ground or air ambulance is used. The routes used by ground vehicles to cross between contaminated and clean areas are considered dirty routes and should not be crossed by clean vehicles, if the mission permits. Consider the effects of wind, weather, and time upon the contaminants; some agents will remain in the area for extended periods of time.

5-78. The relative positions of the contaminated area, FLOT, and anti-access/area denial systems will determine where rotary- or fixed-wing aircraft may be used in the evacuation process. One or more rotary- or fixed-wing aircraft may be restricted to contaminated areas. Normally, contaminated vehicles (air and ground) will be confined to dirty environments.

5-79. Once a rotary- or fixed-wing aircraft has entered a contaminated area, it is highly unlikely that it can be spared long enough to undergo thorough decontamination or

detailed equipment decontamination. However, spot or operational decontamination should be performed to the greatest extent possible. This will depend upon the contaminant, the operating tempo, and the resources available. Immediate or spot decontamination of vehicles is accomplished to minimize crew exposure. The medical platoon must include decontamination procedures in their SOP. See ATP 3-11.32/MCWP 10-10E.8/NTTP 3-11.37/AFTTP 3-2.46 for details on decontamination procedures.

5-80. Keep the rotary-wing rotor wash in mind when evacuating patients, especially in a contaminated environment. The intense rotor wash will disturb the contaminants and further aggravate the condition. The rotary-wing aircraft must be allowed to land and reduce to flat pitch before patients are brought near it. Additionally, a rotary-wing aircraft must not land too close to a PDS (especially upwind) because any trace of contaminants in the rotor wash will compromise the decontamination procedure.

5-81. Evacuation of patients must continue even in a CBRN environment. The medical platoon leadership must recognize the constraints CBRN places on operations and then plan and train to overcome these deficiencies.

5-82. To minimize the spread of contamination inside the ground ambulance, plastic sheeting can be placed under the litter to catch any contaminant that comes off the patient or litter. The plastic sheeting can be removed with the patient, removing any contamination with it. When plastic sheeting is not available, placing a blanket under the litter will reduce the amount of agent that makes contact with the inside of the ground ambulance.

Note. The key to mission success is detailed preplanning. A HSS plan must be prepared for each support mission. Ensure that the HSS plan is in concert with the tactical plan. Use the plan as a starting point and improve on it while providing HSS in a CBRN environment.

5-83. Patient protection during evacuation must be maintained. The Role 1 BAS will not have replacement MOPP ensembles for the patients. These patients must be placed in a CPPW before they are removed from the clean treatment area for evacuation. The CPPW provides the same level of protection as the MOPP ensemble. The patient does not have to wear a protective mask when inside the CPPW. The patient is placed inside the CPPW that is on a litter. The CPPW has a battery-operated blower that can provide a reduction of the body heat load and reduce the carbon dioxide level within the CPPW. The CPPW will provide protection for the patient for up to six hours and is a onetime use item. The blower is reusable and is a decontaminable PMI. Refer to JP 4-02, DODI 6000.11, and ATP 4-02.1 for a discussion of PMIs.

SECTION V – ROLE 1 BATTALION AID STATION DECONTAMINATION

5-84. The decontamination of the Role 1 BAS and mission-essential surfaces and equipment requires a well thought-out process. Fixed-site decontamination capabilities

must be planned, coordinated, tested, and adapted for each role of care medical unit prior to a CBRN incident. Mobile decontamination equipment capabilities may be available at a fixed site to decontaminate buildings, equipment, roads, ramps, and helipads. Loading docks, entries and exits, and building exteriors can be decontaminated with more conventional methods, such as using calcium hypochlorite (in United States Army MES) and soap and water. Commanders should identify all systems capable of contributing to the decontamination effort (for example, water hydrants, fire hoses, fire trucks, steam cleaners, and water pumps). The commander should designate and train teams that can perform decontamination for fixed-site operations. For more detailed information on fixed facility decontamination procedures, types of contamination and how to decontaminate them, and decontamination of specific surfaces and materials, refer to ATP 3-11.32/MCWP 10-10E.8/NTTP 3-11.37/AFTTP 3-2.46. The decontamination of a Role 1 BAS consists of two parts: interior and exterior.

INTERIOR

5-85. When conducting decontamination of the interior of the BAS, the following activities must occur:

- Secure the area or facility.
- Sample to confirm and determine the extent of the contamination.
- Evaluate the sampling results.
- Isolate the areas to prevent the spread of the contamination.
- Remove critical objects for special decontamination procedures.
- Ensure that contamination is not spread or transferred during movement.
- Decontaminate localized areas of the contamination.
- Manage the contaminated waste from the decontamination process.
- Continue monitoring and protecting against low-level exposure risks.
- Document and record the decontamination operations.

MEDICAL EQUIPMENT

5-86. Moisture, dust, and corrosive decontamination materials can damage unsealed electronic equipment circuitry. Most field electronic equipment is watertight for environmental protection which provides good protection against CBRN contamination. Contamination will probably not penetrate gasket-equipped protective covers and sealed components on electronic equipment; but if exposed, the contaminants may be present on the outside of cases containing the electronic equipment. The outside portions of the equipment case must be wiped down with a designated decontaminant. After decontaminating the outside, the equipment must be wiped down with water or an approved solvent to remove traces of decontaminant solutions. If equipment seals appear damaged or the penetration of CBRN contamination into the inside of the equipment is suspected, then the unit should be treated as if it was unsealed. Under no circumstances should electronic equipment be immersed in a decontaminant solution or subjected to high-pressure application of decontaminant solutions.

OPTICS

5-87. Optical systems are extremely vulnerable to decontamination materials that might scratch or adversely affect the lenses. Wipe optical systems with a soft, nonabrasive material such as a lens-cleaning tissue, cotton wadding, or a soft cloth dipped in hot, soapy water. Wipe the optical system with decontaminants. Do not immerse it.

MEDICAL SUPPLIES

5-88. Some medical supplies tend to absorb chemical warfare agents and may not be decontaminated and reused. It may be necessary to burn or bury them if they are heavily contaminated with a chemical warfare agent. When attempting to decontaminate the medical supplies, either calcium hypochlorite dry mix (mixed with dry earth) or slurry (mixed with water to form the chlorine solution) may be used. In comparison, slurry is more effective. In many cases, weathering and cleaning with soap and water may be the preferred decontamination technique if the medical supplies are sealed. If the nonexpendable medical items (such as surgical instruments) must be decontaminated, boiling for one hour in soapy water is the preferred decontaminant for chemical and biological contamination. Radioactive contamination can be removed by brushing and then washing. It may also be vacuumed although a high-efficiency particulate air filter is preferred, and special care should be taken when removing and disposing of the collected radioactive debris from the vacuum system. If CBRN protective covers (tarps or poncho) were used to protect the medical supplies from contamination during a CBRN incident/attack, these covers should be decontaminated, buried, or destroyed after use.

EXTERIOR

5-89. Many materials may absorb contamination and may not be completely decontaminated. The removal or sealing (painting) of these surfaces may be required to reduce the hazard. The decontaminated surfaces should be continually monitored until the detector indicates there is not more off-gassing. As temperatures rise, off-gassing of previously contaminated surfaces may occur at detectable levels. A point detection device should be used to monitor contaminated surfaces.

STRUCTURES

5-90. Wood and concrete tend to absorb liquid agents, and they may give off toxic vapors for days or weeks. Building decontamination is very difficult and requires large quantities of decontaminants. Covering the contamination with plastic sheets, calcium hypochlorite slurry, sodium silicate, or other substances that cover or absorb the agent can reduce the hazard. Even though a particular part of a building is not intended for occupation, it may still need to be decontaminated to prevent the spreading contamination.

RAMPS, ROADS, AND HELIPADS

5-91. Ramps, roads and helipads absorb liquid agents and then give off toxic vapors when heated by the sun. These surfaces may need to be decontaminated several times to reduce hazards. Streets, sidewalks, or other porous surfaces are best decontaminated by weathering if time and the situation permit.

WEATHERING

5-92. Weathering can increase the evaporation of liquid contamination. In a hot, sunny environment, at least 99 percent of the contamination can evaporate within a few hours. Therefore, external building wash down may not be necessary. As a result, vapor concentrations will be high but should not last long. If liquid contamination soaks into soft, porous soil (such as loose sand), evaporation is not as quick. Strong winds also increase the evaporation rate. Low temperatures during the night have a reverse effect and tend to increase the persistency of chemical and biological contamination. The sandblasting effect of sandstorms may remove contamination from surfaces facing the storm. Sunlight and high temperatures will destroy many CB agents without additional decontamination measures if time permits. Rain can help the decontamination process by washing away contamination on exposed surfaces. Rain can also hydrolyze some agents. However, runoff may contaminate the soil.

SECTION VI – PATIENT DECONTAMINATION

5-93. *Patient decontamination* is the removal and/or the neutralization of hazardous levels of chemical, biological, radiological, and nuclear contamination from patients before admission into a Role 1 BAS under the supervision of medical personnel to prevent further injury to the patient during the decontamination process. (ATP 4-02.7/MCRP 3-40A.6/NTTP 4-02.7). This section describes patient decontamination from initial exposure on the battlefield to the patient's treatment in the BAS. This section addresses TTP associated with the performance of patient decontamination after a CBRN incident. Patient decontamination must be in place near the BAS.

5-94. Conducting a patient decontamination at the BAS is a time and resource intensive task that requires planning and detail. In order to accomplish this task, the medical platoon with its complement of nonmedical augmentation trains and rehearses patient decontamination. Rehearsals at the battalion level allow the medical platoon to articulate just how difficult this task is. Detailed unit level SOPs will greatly assist in executing this battle drill. The medical platoon will rely heavily on ATP 4-02.7/MCRP 3-40A.6/NTTP 4-02.7/AFTTP 3-42.3, chapter 5 for detailed instructions on patient decontamination. The medical platoon can utilize GTA 03-08-002 as a quick reference for contaminated casualty care.

CHEMICAL, BIOLOGICAL, RADIOLOGICAL, AND NUCLEAR MASS CASUALTY

5-95. With the employment of CBRN weapons/agents, a MASCAL situation can present itself at any time and at any role of care. Treatment is often limited to life- or

limb-saving care, and triage must be conducted within strict guidelines. It is important that all patients be decontaminated before they are admitted into an uncontaminated area to prevent CBRN hazard spread.

5-96. The roles of military units and organizations need to be defined for a successful preparation, planning, and execution of decontamination operations.

INDIVIDUAL RESPONSIBILITY

5-97. When a Soldier becomes contaminated from a CBRN attack, immediate decontamination is carried out to prevent the Soldier from becoming a casualty. This includes the following:

- Skin decontamination is a basic survival skill and should be performed immediately by the individual or a buddy upon being contaminated.
- Personal equipment wipe down should be performed as soon as possible (preferably within 15 minutes of contamination). This is done to remove contamination from individual's equipment. Use detector paper or a chemical agent detector/monitor to locate the agent. Use a radiological detector to locate radiological contamination and then brush, wipe, or shake it off.

Self-Aid

5-98. Self-aid consists of measures that a Soldier can apply in helping themselves. These include self-administration of antidotes (only for nerve agent exposure) and assumption of the appropriate MOPP level.

Buddy Aid

5-99. Buddy aid consists of emergency actions to restore or maintain vital body functions in a casualty who cannot administer self-aid. Mental confusion, muscular incoordination, physical collapse, unconsciousness, and cessation of breathing may occur so rapidly that the individual is incapable of providing self-aid. These actions include:

- Putting on mask first.
- Immediately decontaminating the casualty's head and placing protective mask on the casualty (if not already masked).
- Administering appropriate antidotes (using the casualty's own antidotes).
- Decontaminating the rest of the casualty.
- Putting the remaining protective clothing on the casualty to preclude further absorption of contamination through any exposed skin.
- Evacuating the casualty as soon as possible.

CONTAMINATED UNIT RESPONSIBILITIES

5-100. Operational and thorough personnel decontamination is carried out by contaminated units (with possible assistance from a decontamination team/unit). This may include individual decontamination beyond the scope of immediate decontamination, decontamination of mission-essential equipment, and limited terrain

decontamination. Operational and thorough decontamination reduces the level of contamination, thus lessening the chance of spread and transfer. When combined with weathering, MOPP levels may be reduced without further decontamination, depending on the surface or material being decontaminated and the agent. See ATP 3-11.32/MCWP 10-10E.8/NTTP 3-11.37/AFTTP 3-2.46 for more information on the decontamination of specific surfaces.

5-101. The contaminated unit is responsible for setting up, operating, manning, and closing the detailed equipment decontamination and detailed troop decontamination (DTD) area at the operational and thorough-decontamination site.

5-102. The higher headquarters of the contaminated unit (company, battalion, or brigade) will coordinate and provide nonmedical augmentees to support the medical unit/facility with patient decontamination.

Note. The CBRN platoons can support operational decontamination if there are no other assets within the battalion headquarters (for example, power-driven decontaminating equipment and operators). The CBRN platoons conduct detailed equipment decontamination but the contaminated unit is responsible for set up, running, and shutdown of the DTD site.

MEDICAL PLATOON OPERATIONS

5-103. Patient treatment, patient evacuation, and protecting its medical staff from exposure to CBRN are the core mission of the medical platoon personnel during a CBRN incident.

5-104. Medical platoon personnel supervise the patient decontamination operations. Nonmedical augmentees from the supported units are required to assist in the decontamination process and perform patient lifting and washing. Eight medical personnel are required to staff a battalion-level PDS. Medically trained personnel are located at the triage area, dirty side EMT areas, litter and ambulatory decontamination areas, clean side of the hot line, and clean treatment area.

5-105. The battalion must plan, prepare, and coordinate to augment the medical platoon with trained nonmedical platoon personnel in support of patient decontamination operations. Additional personnel should be considered to allow for a work-rest rotation of workers. These personnel are split into two categories to assist with either ambulatory or litter decontamination. The designated nonmedical augmentees should train with medical providers assigned to the PDS operations to ensure patient and PDS personnel safety and proper handling of litter and ambulatory patients.

5-106. The Role 1 BAS is not staffed to simultaneously to perform patient decontamination without degrading medical capabilities and capacities. The BAS is capable of conducting split-based operations and may collocate with a CBRN platoon with decontamination capabilities prior to an expected CBRN attack. This allows the use of experienced CBRN defense personnel to augment patient decontamination operations prior to the arrival of units conducting operational or thorough

decontamination. The minimum number of personnel required for basic PDS operation at a Role 1 BAS is eight nonmedical personnel.

MEDICAL SUPPORT IN TROOP/PERSONNEL DECONTAMINATION OPERATIONS

5-107. Medical platoon personnel support the contaminated unit during operational and thorough troop/personnel decontamination or DTD by providing medical support to the site. The brigade level or equivalent is the lowest level that the DTD operation can be effectively planned. The operation requires close coordination between the CBRN officer, logistics staff, battalion surgeon, medical platoon leader, and medical PSG. See table 5-3 on page 5-11 for personnel decontamination information and table 5-4 on page 5-28 for patient decontamination levels and responsible unit.

COLLOCATING PATIENT DECONTAMINATION OPERATION WITH TROOP DECONTAMINATION OPERATIONS

5-108. If personnel and material resources allow, it is ideal to collocate the PDS with troop decontamination so that manpower assets can be shared. Patient and troop decontamination lanes can be near to or parallel to one another, but patients and troops must not be in the same lanes. Troop decontamination must not interfere with patient decontamination operations as the timeliness of patient movement through decontamination once the patient is stabilized is critical.

5-109. If a chemical warfare agent is used and the contaminated unit and the medical unit are collocated for decontamination, it is critical that there is ample room to establish a dirty side triage area just forward of the patient decontamination lanes as ongoing medical stabilization of patients throughout the decontamination process.

5-110. There must be adequate medical staff to man both the PDS areas (for example, conduct triage, supervise patient decontamination and provide EMT during decontamination) and also the supported BAS. A Role 1 BAS will typically lack the medical platoon personnel to staff both a collocated DTD site and another separate PDS immediately adjacent to the BAS. For more information on roles and responsibilities during DTD see ATP 3-11.32/MCWP 10-10E.8/NTTP 3-11.37/AFTTP 3-2.46 and patient decontamination, refer to ATP 4-02.7/MCRP 3-40A.6/NTTP 4-02.7/AFTTP 3-42.3, chapter 5.

5-111. This collocated decontamination area must be close enough to the supported Role 1 BAS to ensure the decontaminated patients can be easily transported to the BAS by designated clean ambulances or other vehicles.

Table 5-4. Patient decontamination levels and responsible unit

<i>Levels</i>	<i>Techniques</i>	<i>Responsibility</i>
Immediate (patient)	Complete decontamination of contaminated areas of patient's mission-oriented protective posture gear prior to evacuation or return to duty, without removing mission-oriented protective posture gear.	Individual/buddy aid or care
Operational/ Thorough (patient)	Decontamination at a patient decontamination site and treatment of conventional and chemical injuries at the Role 1 battalion aid station prior to ground, water, or air evacuation.	Nonmedical augmentees supervised by medical unit/ personnel

5-112. The placement of the DTD or PDS depends upon the situation. The best scenario is to collocate medical patient decontamination and nonmedical DTD side-by-side or in close proximity from each other for easy coordination (preferably near a Role 1 BAS). Personnel who do not require medical treatment will proceed through the DTD site. Personnel who have been injured and who need patient treatment will be decontaminated at the PDS. Patient thorough decontamination involves decontamination procedures for litter and ambulatory patients. This encompasses a series of specific steps for patient medical stabilization, the removal of clothing, wash down, and mask removal before entry into the Role 1 BAS. Refer to ATP 4-02.7/MCRP 3-40A.6/NTTP 4-02.7/AFTTP 3-42.3, chapter 5 for detailed PDS procedures.

PATIENT DECONTAMINATION PRINCIPLES

5-113. The principles and processes of patient decontamination are generally identical throughout the Services, with some variances based on the situation. Suggested patient decontamination procedural aspects will be emphasized in this section. They are based on the available equipment as follows:

- Patient decontamination with minimal equipment (for example, litter stands, buckets).
- Patient decontamination using plumbed tentage, showers, and roller systems.
- Patient decontamination on a water vessel.

5-114. Contaminated patients potentially create increased hazard to first responders, CASEVAC/MEDEVAC teams, medical personnel, and the Role 1 BAS. The three key purposes of patient decontamination are to—

- Protect the Role 1 BAS staff and material.
- Protect evacuation team and equipment along the evacuation route.
- Remove contamination from the patient to reduce agent exposure.

5-115. In some CBRN scenarios, little or no decontamination may be necessary to process a patient especially if lifesaving measures are time critical. The extent to which a patient requires decontamination is dependent on various factors—

- Agent (chemical, biological, radiological, or mixture of agents) and its characteristics (for example, persistent versus relatively nonstable agents, or overall severity of effects).
- Conditions of the release and resulting exposure (for example, liquid versus vapor only).

5-116. Patient decontamination is different from troop or personnel decontamination as patients going through decontamination also have medical conditions that must be managed. The patient decontamination process is carried out by nonmedical augmentees who are supervised by trained medical platoon personnel. These nonmedical augmentees are designated by the supported unit commander. Once designated, the medical platoon would normally train the pool of nonmedical augmentees at home station or in an assembly area.

5-117. Patients who present themselves for decontamination may suffer from the effects of exposure to a CBRN hazard or a toxic industrial material. They can also have conventional wounds, psychological stress reactions, COSR, malingerers; or any combination of these. In addition, patients may have heat injuries induced by extended time spent in MOPP Level 4. It is important to quickly determine whether there is potential for residual contamination on a patient or in bodily fluids for certain infectious biological or radiological hazards that may pose a continued hazard to the patient or a cross contamination to responders/Role 1 BAS personnel. While not all CBRN agents/scenarios require decontamination (See table 5-3 on page 5-11), when in doubt utilize the most protective personal protection and decontamination actions feasible.

5-118. The protective ensemble is worn in a deployed environment where there is an expected CBRN threat. Patients wearing the protective ensemble are protected from CBRN threats and hazards in either dry solid, liquid, vapor, or gas form. Removing a contaminated uniform or protective ensemble will remove approximately 95 percent or more of the agent. Foreign objects in wounds (for example, shrapnel) or torn ensemble will cause a breach in the protective ensemble, allowing agents to reach and contaminate the tissues. Individuals not wearing a protective ensemble will have little or no protection when exposed to an agent. Regular clothing can absorb liquid agent, allowing it to touch the skin. Fabric weave can also hold chemical vapors or aerosolized biological agents. In general however, external clothing removal and rinsing of exposed skin and hair with water or soap and water is generally considered adequate decontamination for most chemical vapor only exposures or biological aerosols.

5-119. While these guidelines apply specifically to the conflict scenario, the same principles and techniques can be readily applied to a homeland, garrison/installation, or civilian setting.

WARNING

Cross contamination of patients by decontamination personnel can result in further injury to the patient. Decontamination personnel handling patients must be cleaned or be thoroughly decontaminated prior to and in between handling patients. Chlorine solution requires contact time with agent for complete neutralization dependent on the ambient temperature. Ensure decontamination personnel have waited a sufficient amount of time before handling patients to allow for this contact time to neutralize agent.

ZONES OF CONTAMINATION

5-120. A contaminated area is divided into three zones of contamination (hot, warm, and cold [see figure 5-1), modified following the guidelines prescribed in the Environmental Protection Agency Standard Operating Safety Guidelines and the Occupational Safety and Health Administration Act (Section 1910.120, Part 1910, 29 CFR 1910.120). To more effectively manage the contaminated area, a variety of control lines and points are designated depending upon the level of contamination. These same areas hold true in the battlefield.

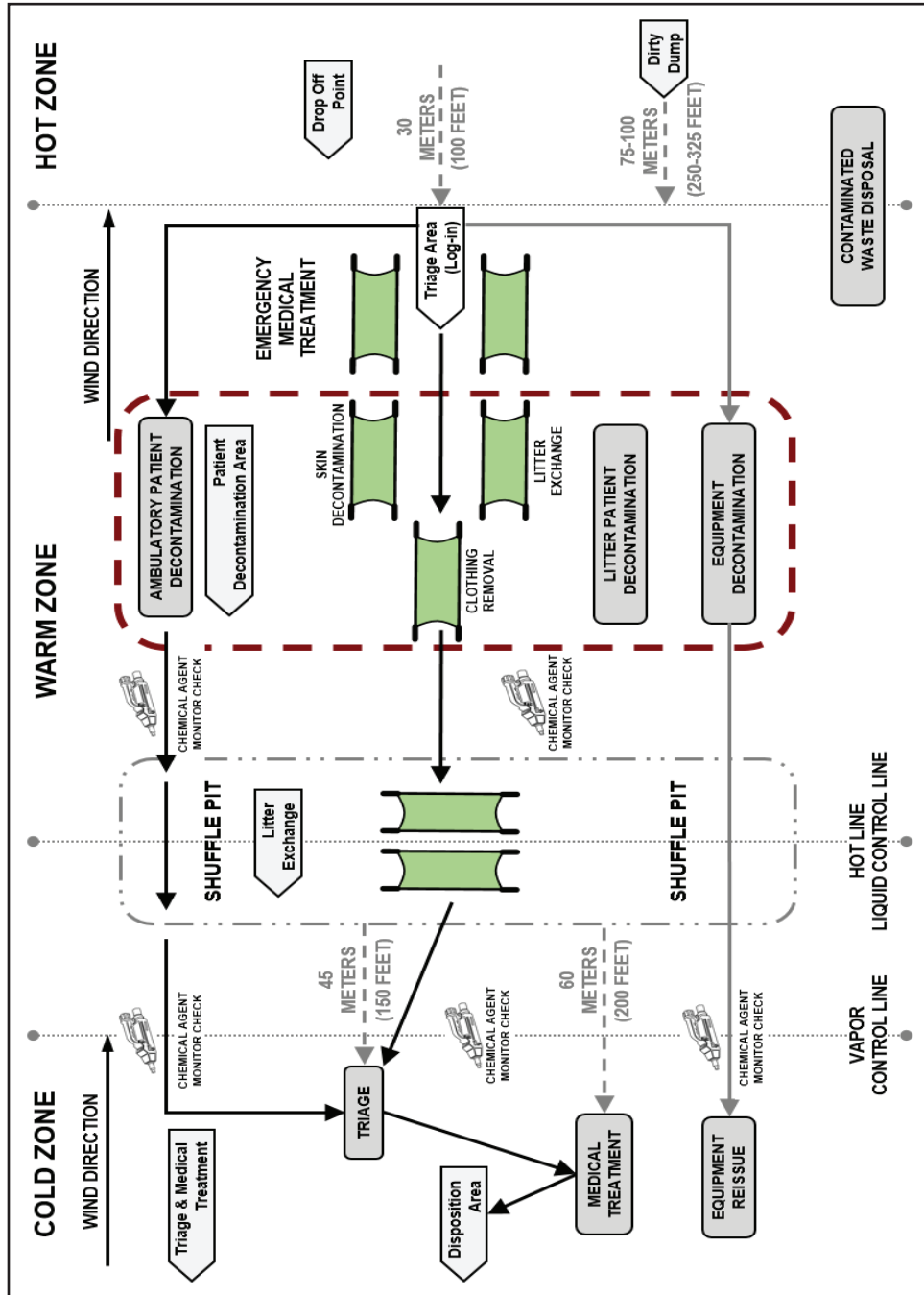

Figure 5-1. Patient decontamination site layout

HOT ZONE

5-121. The hot zone is also called exclusion zone, red zone, or restricted zone. This is the area that is directly contaminated by CBRN agents. In combat, this is the contaminated battlefield or toxic industrial material release. Patients usually undergo immediate decontamination in the hot zone or near it. The MOPP Level 4 will provide protection against chemical warfare agents (for example, chlorine, phosgene, mustard, nerve agents, and cyanide) in an open battlefield environment where the vapor is dispersed by the wind currents. The military protective ensemble is not intended for oxygen-depleted areas or for long-term use in confined spaces with high concentrations of toxic industrial chemical. In a confined space or where nonbattlefield toxic industrial chemical (for example, ammonia or carbon monoxide) are used, a self-contained breathing apparatus, or special filters that will protect against the specific toxic industrial chemical must be used (refer to figure 5-1 on page 5-31).

WARM ZONE

5-122. This is an area where low levels of dry, liquid, and vapor contamination can be expected once contaminated individuals enter this area. The contamination hazard is essentially the agent that remains on the patients who are brought into this zone (for example, the primary hazard comes from liquid or dry agent on clothing or the off gassing of vapors from liquid contaminated garments and equipment). While the direct hazards to workers is reduced compared to those working in the hot zone, the protective ensemble must be worn by decontamination team members as vapors and particles, even in small amounts, can pose a hazard to those working directly with the patients. The warm zone is located outside of the hot zone. In this zone, immediate, patient operational, and patient thorough decontamination take place uphill, upwind, and upstream of the hot zone incident location. The PDS is initially set up in an area free of contamination. This area becomes part of the warm zone once contaminated casualties begin to arrive. This zone includes control points in and out of the patient decontamination area so that contamination spread is restricted. Protective ensemble at MOPP Level 4 provides adequate protection in the warm zone. The evacuation corridor is within the warm zone. This includes land evacuation routes for casualties who may still be contaminated. The PDS is located in that corridor. All patients are routed through this corridor toward the Role 1 BAS. In some instances, patients who have only undergone immediate and patient operational decontamination may be dirty evacuated over or through a clean area for thorough decontamination at a larger role of care unit like a Role 2 BSMC. In this case, a separate warm area would be created at the vehicle drop-off point and decontamination area at the destination BAS (see figure 5-1 on page 5-31).

COLD ZONE

5-123. The cold zone is an area free from liquid and vapor contamination. The PDS and BAS are initially set up in the cold zone. All personnel and patients entering this zone have been decontaminated. Protective ensemble and mask are usually not required for personnel downwind of the cold zone unless the area becomes contaminated or the patient demonstrates symptoms of a respiratory communicable disease. Standard

precautions must be practiced if a patient is infected with an infectious biological warfare agent (refer to figure 5-1 on page 5-31).

SAFETY, HEAT INJURY PREVENTION, AND WATER CONSUMPTION

5-124. One of the concern to decontamination team members is heat injury and musculoskeletal injury from performing moderate to heavy patient triage and treatment and heavy work carrying litter patient and decontaminating patients while wearing the protective ensemble. The frequency of accidents, in general, appears to be higher in hot environments than in more moderate environmental conditions. One reason is that working in a hot environment lowers the mental alertness and physical performance of an individual. Increased body temperature and physical discomfort promote irritability, anger, and other emotional stresses which sometime cause workers to overlook safety procedures or divert their attention from hazardous tasks. It is critical that these issues be addressed throughout PDS operations.

5-125. A safety officer must be appointed for PDS operations. This can be the PDS noncommissioned officer in charge (NCOIC) or appointed individual selected by the commander. The primary duty of this individual is to conduct an initial and ongoing risk assessment prior to setting up the PDS and to personally monitor the status of decontamination team members working on the warm side of the hot line at all stations from the entry control point (ECP) to the hot line. This individual must not be involved in PDS tasks such as triage, treatment, litter carry, or patient decontamination. They must be free to move around the warm zone. In addition to personally checking with decontamination team members and observing them closely for signs of heat or musculoskeletal injury, this individual manages work/rest cycles, monitors temperature, and wet bulb heat category conditions, ensures adequate fluids are available for decontamination team members, and enforces safe patient lifting techniques.

5-126. Worker musculoskeletal injury can easily occur from long periods of patient lifting and litter carrying or injuries caused by falls while wearing protective ensemble. musculoskeletal injuries that can also occur from the set-up, tear-down, and manual material handling of equipment and supplies during set-up and tear-down, and restocking operations. To reduce these injuries, the following strategies can be implemented:

- Clear routes within the PDS to reduce slipping, tripping, and falling hazards.
- Establish multiple decontamination lanes far enough apart to reduce cluttered work areas.
- Ensure that garbage bags containing contaminated waste material are moved from the decontamination lanes to the dirty dump on a regular basis to reduce tripping hazards in the decontamination area.
- Ensure that litter teams move litter patients at a safe speed and walk when transporting patients.
- Reduce distances that litters need to be transported by litter teams.
- Mark triage areas and litter transport lanes for all operations.
- Enforce proper lifting and litter carry techniques throughout PDS operations.

- Ensure that personnel performing litter carries and patient lifting are fit for the demands of the task.
- Enforce frequent rest breaks that include snacks and hydrating.
- Use equipment that assists with patient lifting (for example, roller systems, litter stands, or NATO litter carriers) when available.

Heat Injury

5-127. Wearing the protective ensemble can bring about a variety of heat-induced disorders or heat injuries, including heat cramps, heat exhaustion, and heat stroke, especially when working in a warm or hot work environment. The chemical protective ensembles make it difficult for the body to cool itself as it prevents sweat from readily making contact with the air to help cool the skin. This inhibits heat transfer from the body. A previous history of heat injury can increase a person's risk for another heat injury; prior heat injury personnel should be clearly and easily identifiable on the front and back of their protective suits in accordance with unit SOP. Taking certain medications, especially medications with anticholinergic effects, such as atropine and pseudoephedrine, can interfere with sweating mechanisms and increase the risk of heat injuries.

5-128. Heat cramps, heat exhaustion, and heat stroke are not separate conditions, but can be a continuum of increasingly more serious medical conditions as a person remains exposed to the hot work environment. Without effective and appropriate interventions, an individual can rapidly progress to the most serious heat injury, heat stroke, which can result in serious morbidity or death.

Heat Cramps

5-129. Heat cramps are painful spasms of the muscles that occur among those who sweat profusely in the heat and who drink large quantities of water but do not adequately replace the body's salt loss.

5-130. Humans are, to a large extent, capable of adjusting or acclimatizing to a hot environment. This acclimation to heat, under normal circumstances, usually takes about 5 to 7 days, during which time the body will undergo a series of physiological changes that will make continued exposure to heat more endurable. Measures that can be taken to reduce heat load on the individual include:

- Ensure that work/rest cycles are enforced and that manning is adequate to accomplish this.
- Provide shaded areas for rest on the warm side of the hot line.
- Provide shaded covering (for example, camouflage netting or open tentage) over decontamination and warm side triage and treatment areas.
- Reduce MOPP level when appropriate.
- Maintain adequate supplies of drinking potable water for decontamination team members.
- Ensure Soldiers are drinking the recommended amount of water based on their workload.

Heat Exhaustion

5-131. This includes several clinical disorders having symptoms which may resemble the early symptoms of heat stroke. Heat exhaustion is caused by the loss of large amounts of fluid by sweating, sometimes with excessive loss of salt.

Heat Stroke

5-132. This is a life-threatening medical condition associated with working in hot environments. It occurs when the body's temperature regulatory system fails and sweating becomes inadequate. The body's only effective means of removing excess heat is compromised with little warning to the victim that a crisis stage has been reached.

Work/Rest Cycles and Water Consumption

5-133. It is critical that the decontamination teams be properly staffed and the decontamination workload of the teams be distributed among the members so that proper work/rest cycles can be maintained and workers do not keep working to the point of heat or musculoskeletal injury. In a high operating tempo, team members may disregard this important guidance. Not enforcing appropriate work/rest cycles will increase the risk for decontamination team member injury and will deplete the manpower pool. Properly managed work/rest cycles ensure the team members have the opportunity to rest, hydrate, cool down, and recover from the effects of fatigue.

5-134. According to TB MED 507/AFPAM 48-152(I), the following example activities are considered easy work: weapon maintenance, marksmanship training, drill and ceremony, manual of arms, and walking on hard surface at 2.5 miles per hour with less than 30 pounds of load. The following example activities are considered moderate work: calisthenics, patrolling, individual movement techniques (low or high crawl), defensive position construction, walking on loose sand at 2.5 miles per hour with no load, or walking on hard surface at 3.5 miles per hour with less than 40 pounds of load. The following example activities are considered hard work: field assaults, walking on hard surface at 3.5 miles per hour with more than 40 pounds of load, or walking on loose sand at 2.5 miles per hour with any kind of load. Refer to table 5-5 on page 5-36 for work/rest cycles and water consumption information. This table applies to an average sized, heat-acclimated Soldier wearing their duty uniform.

Table 5-5. Work/rest cycles and water consumption

Heat category	WBGT ^{1,2} index degrees F	Easy work		Moderate work		Hard work	
		Work/ rest ^{3,4}	Water intake ⁵ qt/hr	Work/ rest min	Water intake qt/hr	Work/ rest min	Water intake qt/hr
1 (WHITE)	78 to 81.9	NL ⁶	0.50	NL	0.75	40/20	0.75
2 (GREEN)	82 to 84.9	NL	0.50	50/10	0.75	30/30	1.00
3 (YELLOW)	85 to 87.9	NL	0.75	40/20	0.75	30/30	1.00
4 (RED)	88 to 89.9	NL	0.75	30/30	0.75	20/40	1.00
5 (BLACK)	More than 90	50/10	1.00	20/40	1.00	10/50	1.00

¹If wearing body armor, add 5° F to WBGT index in humid climates.
²If wearing IPE (MOPP 4), add 10° F to WBGT index for easy work, and 20° F to WBGT index for moderate and hard work.
³The work/rest times and fluid replacement volumes will sustain performance and hydration for at least 4 hours of work in the specified heat category. Fluid needs can vary based on individual differences (± 0.25 qt/hr) and exposure to full sun or full shade (± 0.25 qt/hr).
⁴Rest means minimal physical activity (sitting/standing), accomplished in shade if possible.
⁵CAUTION: Hourly fluid intake should not exceed 1.5 quarts and daily fluid intake should not exceed 12 quarts.
⁶NL= No limit to work time per hour (hr).

Legend:
F Fahrenheit
hr hour
min minute
MOPP mission-oriented protective posture
NL no limit
qt quarts
WBGT wet bulb globe temperature

5-135. Portable heat stress meters or monitors are used to measure heat conditions. These instruments can calculate both the indoor and outdoor wet bulb globe temperature index. With this information and information on the type of work being performed, heat stress meters can determine how long a person can safely work or remain in a particular hot environment. See table 5-6 for information on permissible heat exposure thresholds for PPE.

Table 5-6. Permissible heat exposure threshold limit value

Work/rest regimen	Work load*		
	Light	Moderate	Heavy
Continuous work	30.0°C (86°F)	26.7°C (80°F)	25.0°C (77°F)
75% Work, 25% rest, each hour	30.6°C (87°F)	28.0°C (82°F)	25.9°C (78°F)
50% Work, 50% rest, each hour	31.4°C (89°F)	29.4°C (85°F)	27.9°C (82°F)
25% Work, 75% rest, each hour	32.2°C (90°F)	31.1°C (88°F)	30.0°C (86°F)

*Values are in °C and °F, wet bulb globe temperature index.
These threshold limit values are based on the assumption that nearly all acclimatized, fully clothed workers with adequate water and salt intake should be able to function effectively under the given working conditions without exceeding a deep body temperature of 38°C (100.4° F). Add 10°F if wearing PPE and conducting light work. Add 20°F if wearing PPE and conducting moderate to heavy work.

Legend:
C Celsius
F Fahrenheit
PPE personal protective equipment

CAUTION

The toxicological agent protective (TAP) apron adds an additional 10 degrees to the wet bulb globe temperature index.

Wearing protective suit adds 10°F (5.6°C) to the wet bulb globe temperature index and if conducting moderate or hard work and wearing protective suits, add 20°F (10.2°C) to wet bulb globe temperature index.

Wearing body armor increases this by another 5°F (2.8°C).

A worker may produce as much as 2 to 3 gallons of sweat in the course of a day's work. Because many heat disorders/injuries involve excessive dehydration of the body, it is essential that water intake during the workday be about equal to the amount of sweat produced.

5-136. Most workers exposed to hot conditions drink less fluid than needed because of an insufficient thirst drive. A worker should not depend on thirst to indicate when and how much to drink. Thirst is a poor or late indicator of dehydration, so most workers exposed to hot conditions drink fewer fluids than needed to replace lost fluids. Five to seven ounces of liquid should be consumed every 15 to 20 minutes to replenish the necessary fluids in the body. Water intake should not exceed 1.5 quarts per hour or 12 quarts per day, as excessive water consumption (overhydrating or hyponatremia) can dilute the salt content of the blood to the point where it interferes with brain, heart, and muscle function. This water intoxication can result in confusion, nausea, vomiting, seizures and/or death.

CAUTION

Hourly fluid intake should not exceed 1½ quarts (one and one half canteens) and daily fluid intake should not exceed 12 quarts (12 canteens).

5-137. Heat acclimated Soldiers lose much less salt in their sweat than do those who are not acclimated. The average Soldier's diet contains sufficient salt for acclimatization even when sweat production is high. If for some reason, salt replacement is required, the best way to compensate for the loss is to add a little extra salt to the food. Salt tablets should not be used unless directed by a physician. Soldiers on low sodium diets who work in hot environments should consult a physician about what to do under these conditions.

COLLECTIVE PROTECTIVE SHELTER SYSTEM

5-138. The establishment of a PDS should be one of the first priorities once a BAS is established in an area with the threat of CBRN weapons use.

5-139. Setting up the Role 1 BAS in existing structures (concrete or steel buildings) provides greater protection from hazards and eliminates many decontamination problems. However, without means to seal openings, chemical warfare agent vapors can enter the structure. The addition of chemical/biological (CB) filtration systems with airlocks that provide overpressure, can provide maximum protection for occupants. Entry and exit procedures must be established to prevent contamination being introduced by personnel and patients entering. Without collective protective shelter systems (CPS), hospitals may operate for a limited time in a nonpersistent agent environment but are incapable of operating in a persistent agent environment.

5-140. Chemical/biological filters for fixed-site hospital ventilation systems will be a critical item of supply. Controlled entry and exit points with sufficient space to permit placement of litter patients and/or numbers of personnel that permit purge of vapors will have to be established. All windows, doors, and other points that may have air leaks will have to be sealed (use tape and plastic sheeting) to enable the facility to have a positive overpressure to keep CB agents out.

5-141. Liquid chemical warfare agents can penetrate general purpose tentage in about six hours or less. These agents will penetrate the wrappings on medical supplies and equipment, especially, sterilized equipment and supplies, paper-wrapped cotton sponges, and open or lightly closed medications/solutions. They can also contaminate water/food supplies. Therefore, equipment and supplies must be stored in protected areas or under protective coverings. Some of the factors to consider when deciding to set up a CBPS system include:

- Without a CBPS system, treatment procedures involving open wounds or the respiratory tract in the presence of a CB agent hazard is limited. Exposing open wounds and the respiratory tract to the agent increases the effects of these agents on the patient.
- Without hardened protection, the Role 1 BAS, staff, and patients are susceptible to the effects (blast, thermal, or radiation) of nuclear weapons.
- The Role 1 BAS electrical and electronic medical equipment is vulnerable to the effects of the electromagnetic pulse produced by nuclear weapons. The electromagnetic pulse is not harmful to humans, animals, or plants but is very damaging to electronic equipment.
- The Role 1 BAS equipment is very difficult to decontaminate. Aging (allowing the agent to off-gas or the radiological isotope to degrade) may be the only means of decontamination.
- Concealment and good operations security will help prevent identification of a unit.

5-142. Dispersion is a defensive measure employed by the medial platoon. This allows the medical platoon protect its personnel, equipment, and supplies or limits those remaining in a contaminated area.

5-143. The MOPP ensemble does not protect against all radiation effects of nuclear weapons. However, it provides some protection against alpha- and beta-radiation burns. By covering all body surfaces, especially hairy areas, MOPP greatly expedites the decontamination process.

BATTALION AID STATION COLLECTIVE PROTECTIVE SHELTER SYSTEM

5-144. The CBPS (M8 and M8E1) is a highly mobile vehicle-mounted rigid-wall shelter with an attached chemical and biologically protected airbeam supported tent. The M8E1 will soon replace some of the M8 versions of CBPS. The CBPS provides an environmentally controlled work area that filters out CBRN agents. It will not protect personnel or patients from the thermal, blast, and initial radiation effects of nuclear weapons; however, it will provide some protection against fallout effects. The CBPS is designed to be employed at the deployed Role 1 BAS and Role 2 BSMC. The CBPS (M1 System) is permanently integrated with a mobile dedicated platform and is attached to the hard-walled box on the rear of a high mobility multipurpose wheeled vehicle (see figure 5-2). The M8E1 version of CBPS is attached on the rear of a mobile tactical vehicle.

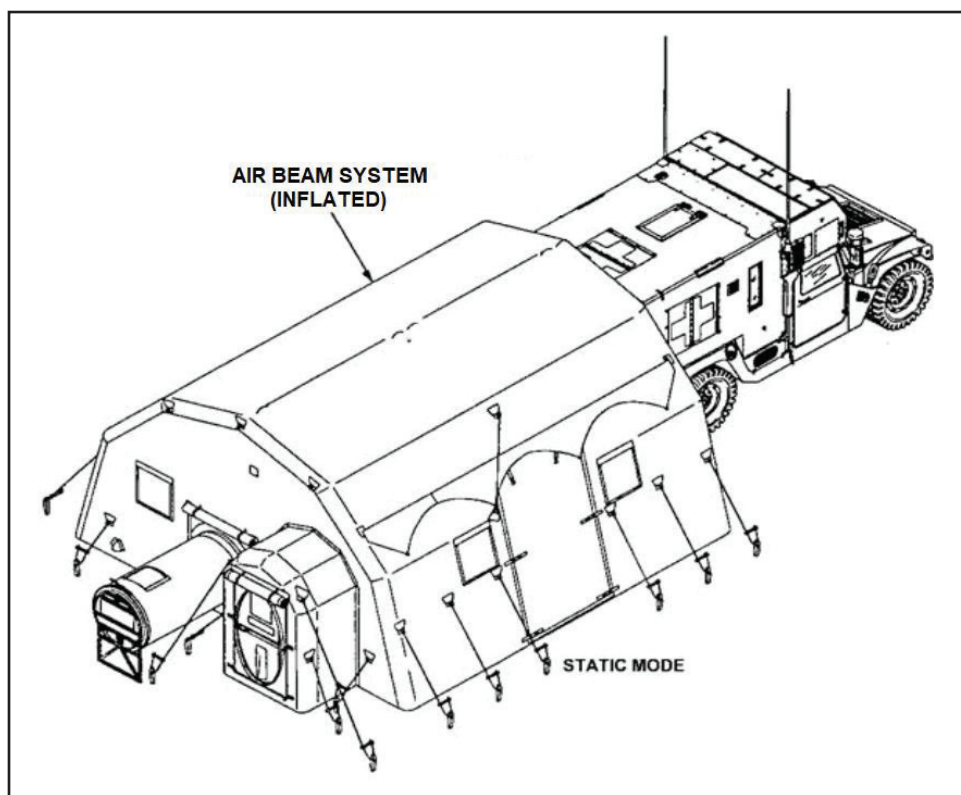

Figure 5-2. Battalion aid station, chemical-biological protective shelter system

- The Role 1 BAS has one CBPS system per treatment team (minus the CAB); the Role 2 BSMC has four CBPS systems; while the FRSD has three CBPS systems. Systems can also be issued to other selected medical treatment teams.
- Patients held inside the CBPS are those that have been decontaminated and admitted into the system for treatment or are recovering from the treatment procedures and are awaiting evacuation.

Note.

1. Normally, patients will not be held at the medical company (brigade support battalion) Role 2 BSMC under CBRN conditions unless evacuation cannot be accomplished. They should be RTD or evacuated to a clean role of care unit as soon as the mission permits.
 2. The CBPS can also be employed as the Role 1 BAS in the conventional mode. Employment in either mode still requires general purpose tentage for patient holding to meet total patient holding requirements.
-

5-145. The M20/M20A1 simplified collective protection equipment (CPE) is another system that is available to provide collective protection to existing structures. It consists of a chemically protected room liner, a CB filter blower, and an ambulatory airlock. However, it does not have a litter airlock making it unsuitable for litter patient care. The M20/M20A1 may be used to protect medical staffs and patients at the Role 1 BAS.

EMPLOYMENT OF THE CHEMICAL-BIOLOGICAL PROTECTIVE SHELTER SYSTEM

5-146. When operating under a CBRN threat or when a CBRN attack is imminent, the Role 1 BAS must prepare for continuation of its mission. Should an attack occur, the BAS must seek out a contamination-free area to establish a clean treatment area or must be collectively protected by using CBPS.

Establish a Role 1 Battalion Aid Station in a Chemical Biological Protective Shelter

5-147. One CBPS per treatment squad in a Role 1 BAS is used for conventional operations in a split-team mode. When operating in a squad configuration and in the conventional mode, two CBPS systems may be combined to provide more workspace. However, the treatment squad is not staffed to operate the two systems in the CB mode.

5-148. When the two systems are not combined, the treatment squad must operate in the CB mode and must use only one system. Although each treatment team of the BAS has a CBPS, only one system is set up when operating in the CB mode. This is due to the lack of authorized personnel to operate all systems at one time in the CB mode. Eight medical platoon personnel are required to operate the BAS (employing one CBPS) in the CB mode. At least eight nonmedical personnel are required to perform patient decontamination under medical supervision.

5-149. By setting up one system in the CB mode, it provides the BAS the ability to retain its flexibility in order to maintain its support mission of being where it is needed and when it is needed. The CBPS can be used as the treatment shelter in the conventional mode as well. When the treatment squad is operating in the split-team mode, each team will have a CBPS for use as its treatment shelter. When operating one system in the CB mode, the other system provides a replacement in the event it is damaged beyond repair. This ensures continued HSS to the command.

5-150. When setting up the PDS, the contaminated ambulance point, contaminated triage point, patient decontamination area, and contaminated treatment area is established on the downwind (prevailing wind) side of the CBPS. An overhead cover of plastic sheeting (approximately 6 meters wide by 15 meters long [20 feet wide by 50 feet long]) is set up over the PDS, the hot line, and the clean treatment/waiting area. The cover must overlap the airlocks. The clean treatment/waiting area should have an area at least 6 meters wide by 5 meters long (20 feet wide by 15 feet long) to allow space for placing patients into the litter airlock without crossing the hot line. For detailed instructions on setting up a PDS in a CPS see ATP 4-02.7/MCRP 3-40A.6/NTTP 4-02.7/AFTTP 3-42.3, chapter 12.

5-151. A second area covered with 6 meters by 8 meters (20 feet by 25 feet) of plastic sheeting (the evacuation holding area) is set up beside the shelter on the opposite side from the generator. The clean treatment area is separated from the decontamination area by a hot line with a shuffle pit. Only clean (decontaminated) patients or personnel are allowed to cross the hot line into the clean treatment area or are admitted into the CBPS. Each CBPS provides a minimum of 90 square meters (300 square feet) of work area. Figure 5-3 on page 5-42 presents one layout of a BAS using the CBPS. See TM 10-5410-228-10 for complete details on setting up, operating, and maintaining the CBPS.

Note. The overhead cover is not needed when the wind speed exceeds 10 knots per hour. The plastic will not stay in place.

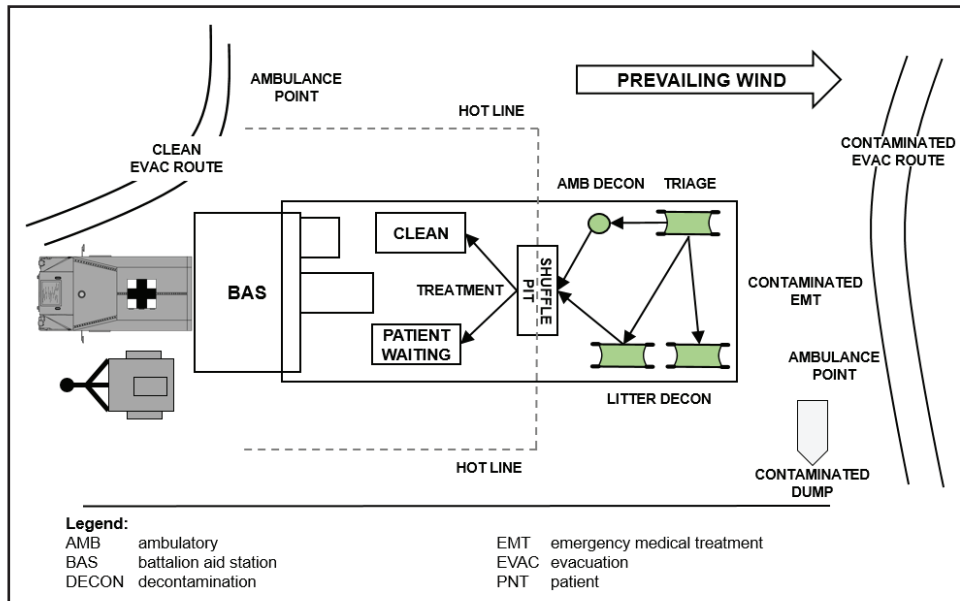

Figure 5-3. Battalion aid station using the chemical-biological protective shelter

Establish Collective Protective Shelter Using the M20 Simplified Collective Protective Shelter System

5-152. The M20 simplified CPE is used to establish a CPS within a room of opportunity or inside a tent; however, the available space will be limited by tent poles and other components of the tent. Currently, this system only provides ambient temperature air.

5-153. The M20 simplified CPE provides a clean-air shelter for use against chemical and biological warfare agents and radioactive particles. It is lightweight and mobile and it allows unit commanders to convert existing structures into protected working or rest area. The M20 simplified CPE can be used as a temporary rest and relief shelter (for example, as a break area for medical platoon personnel) or as a command and control center. It provides a contamination-free environment in which 10 Soldiers can work, eat, or rest without wearing an IPE. The M20 simplified CPE can be erected without the liner using only the protective entrance and blower compartment. Places such as a bank vault or warehouse freezer are examples of where an M20 without liner can be placed. Any cracks or holes will need to be sealed in the doorway. A bib section is available that will fit between the protective entrance and the frame of any door, and when taped down, seals the entrance from outside contamination. Entry and exit restrictions remain the same. For guidance on maintenance and parts of the simplified CPE see TM 3-4240-288-12&P. The M20 does not have a litter airlock. Only staff or ambulatory patients can enter.

ESTABLISHING A PATIENT DECONTAMINATION SITE

5-154. Once a Role 1 BAS is set-up in an area with the threat of CBRN weapons use the medical platoon should make pre-selecting locations for the establishment of a PDS one of its first priorities. Listed below are considerations the medical platoon should take when planning for and training to conduct patient decontamination operations.

PATIENT THOROUGH DECONTAMINATION (MINIMAL EQUIPMENT)

5-155. The following guidelines should be followed for patient decontamination when minimal decontamination equipment is available. These procedures are most applicable to mobile hospital units that have limited transport capability for carrying decontamination tents and roller systems.

Note. Standard Army patient decontamination and chemical treatment MES is designed to decontaminate 60 patients exposed to CBRN hazards and treat 60 chemical patients.

5-156. The PDS can be collocated with a troop decontamination unit if adequate medical transportation assets and medical staffing are available.

5-157. The PDS can also be located adjacent to the Role 1 BAS and not collocated with a troop decontamination unit. In this instance the PDS must be located 30 meters (100 feet) or more away from the BAS as wastewater runoff can potentially contaminate the area. If there is an adequate means to collect wastewater runoff, such as the use of a plastic water collection berm and pumps to remove the water, then the PDS facility can be located closer to the BAS.

SELECTING AND PREPARING THE SITE PRIOR TO PATIENT ARRIVAL

5-158. The PDS is initially set up in an uncontaminated (clean) area. It only becomes a warm hazard area once contaminated patients begin to arrive. The greatest threats to decontamination team members are from liquid or dry agents on a patient's protective ensemble and from chemical agent vapor that is trapped in clothing and hair or coming from liquid on clothing.

Note. Planning and preparation for the establishment of a PDS must take place long before it is to be employed.

5-159. Select a site that has the following characteristics:

- Access to a road network for easy movement of patients to and from the PDS and for trucks to maneuver dropping off or refilling water bladders, if used.
- Ground that is downhill or slopes away from the Role 1 BAS or clean side, if possible, for PDS with minimal equipment. For PDS with a roller system, ground is preferably level for tent set-up.
- Downwind (prevailing winds) from the Role 1 BAS or clean side.

- Location where wastewater runoff will not contaminate existing water resources or ground near the Role 1 BAS.
- Adequate security for decontamination personnel.
- Adequate space to establish a drop-off point with associated warm side triage and treatment areas that can be quickly and easily expanded to handle more than the anticipated number of casualties.
- Large areas, one on the clean side and the other on the dirty, for the staging of dirty and clean patients for evacuation.

Staffing of the Patient Decontamination Site with Minimal Equipment

5-160. The following is the staffing required for one work cycle. More individuals are needed to ensure adequate work/rest cycle rotation. Refer to table 5-7 for suggested information on minimal staffing for one work cycle.

Table 5-7. Suggested minimal staffing for one work cycle

<i>Duty</i>	<i>Minimal</i>	<i>Roller system</i>
Command and Control Cell		
Officer in charge.	1	1
Noncommissioned officer in charge.	1	1
Entry Control Point		
Entry control point security detail.	2 (optional)	
Nonmedical augmentees to unload litter patients (2 teams of 4).	8	8 (4 if NATO litter carriers are used)
Security personnel to guard arrival point and perform pat-down search.	2 (optional)	2 (optional)
Road guides and lookouts (night operations).	3 (optional)	3 (optional)
Nonmedical augmentee trained to use various contamination check tools.		1 (optional)
Triage and Emergency Medical Treatment Area (Warm Side)		
68W or other primary triage officer (physician assistant, nurse).	1	1
68Ws to administer treatment.	1	1
Nonmedical augmentees to serve as litter bearers (2 teams of 4 personnel).	8	

Table 5-7. Suggested minimal staffing for one work cycle (continued)

<i>Duty</i>	<i>Minimal</i>	<i>Roller system</i>
Litter Decontamination Area (Per Litter Lane)		
Nonmedical augmentees who decontaminate the patients and perform patient lifts wear TAP apron.	4	
Medical platoon personnel.	1	1
Nonmedical augmentee to clean litters.	1 (optional)	
Clothing removal area of roller system.		2
Body wash area of roller system.		2
Final check area of roller system.		1
Ambulatory Decontamination Area (Per Lane)		
Nonmedical augmentee to assist patients.	1 (optional)	1 (optional)
Medical platoon personnel.	1	1
Contamination Check Area		
Nonmedical augmentees trained to use various contamination check tools.	1	
Hot Line Patient Reception (Members on the Clean Side of the Hot Line)		
Nonmedical augmentees on clean side of the hot line who move litter patient across hot line.	2	2 (1 if NATO litter carriers are used)
Combat medic on clean side of hot line.	1	1
Total medical	5	5
Total nonmedical augmentees/others	25–34	14–23
Total personnel for one work cycle	30–39	19–28
Note. This minimal staffing does not include Role 1 battalion aid station security detail.		
Legend:		
NATO North Atlantic Treaty Organization		
TAP toxicological agent protective		

Note. At a Role 1 BAS, patient decontamination requires a minimum of eight nonmedical augmentees from the supported unit. A dramatically reduced decontamination operation less than the recommendation above, may be necessary. In this instance it is critical to have one or two individuals who can adequately triage, stabilize, and evacuate dirty casualties who cannot be cared for at that facility. Those who can be seen there must have their clothing carefully removed by a team of four nonmedical augmentees, supervised by medical platoon personnel. This must be performed before the patient is moved across an improvised hot line. At the hot line, the patient is received by another set of nonmedical augmentees and a member of the medical staff wearing MOPP Level 4. Only then is the patient moved inside a clean area where medical staff are not wearing protective ensemble. The key here is for the Role 1 BAS to reroute contaminated patients to another BAS if they are overwhelmed.

Establishing a Patient Decontamination Site

5-161. Mark off areas for dirty dump, drop-off point, triage, dirty EMT, litter lane, ambulatory lane, contamination check, hot line, dirty litter decontamination, dirty side shaded rest area, clean side supply, clean side triage and treatment, clean side transport area to Role 1 BAS, temporary morgue holding area, and patient weapons storage area. The environmental control units, water heater, power source, and water bladders in a PDS with plumbed tentage can also be marked.

5-162. Set up the PDS so that it can be easily marked with chemical lights and negotiated in night conditions. Remove debris along the routes between the drop-off point, triage and treatment areas, and decontamination lanes. When conducting triage—

- The immediate category patients are moved to the warm (dirty) side EMT. This area is located between patient triage (closer to triage to minimize the time it takes to move from triage to dirty EMT) and the entrance to the litter decontamination lanes. This way they can be moved to litter decontamination without interfering with the traffic flow from other patient groups.
- The delayed category patient area should be positioned nearer to the entrance to both the litter and ambulatory decontamination lines. This way delayed patients can be processed through either the litter or ambulatory lanes when the lanes become available.
- Minimal category patients should be positioned near the ambulatory patient area so if medical care on the clean side of the hot line is needed they can process through the ambulatory lane when it becomes available and will not interfere with the flow to the litter lanes.
- Expectant category patients should be located near the EMT area but farther away from the decontamination lanes so that they can be triaged and stabilized for decontamination if the EMT area no longer has patients in it.

Note. More than one patient litter decontamination lane is needed, especially for a Role 2 or Role 3 medical unit, as the process takes time and is labor intensive.

Establish a Security Perimeter Around the Patient Decontamination Site

5-163. This should be done by erecting barriers such as concertina wire. Using vehicles as barriers may not be appropriate if access to these vehicles will be required during patient decontamination operations and the vehicles will be located in the potential warm area of the PDS. These measures will be dictated by situation.

5-164. Dig a dirty dump at least 75 meters (250 feet) downwind from the arrival point. The dump should be at least two meters (six feet) deep and large enough to accommodate large numbers of filled contaminated trash bags (one for every two decontaminated patients). The dump should be deep enough so that bags can be covered once the PDS is evacuated or closed down. The medical platoon leadership supports the commander by ensuring that proper local regulations, host nation regulations, and/or licensing mandates are followed for storing and/or burying CBRN waste.

Note. Preparing a dirty dump while the area is uncontaminated is much easier as workers will not have to assume MOPP Level 4. Once contaminated material is placed in the dump then any expansion of the dump will have to be performed by individuals digging the dump while at MOPP Level 4. It is best to coordinate this with an engineer unit early, so they can use their earth-moving equipment to dig the holes for dirty dump and construction of wastewater diversion gullies.

5-165. Dig water runoff gullies (approximately one foot deep) or berms (approximately one foot high) around the litter and ambulatory decontamination areas to trap any water flow and route it away from the decontamination area if plastic berms are not available. These should direct water to a larger pit where wastewater can be collected if it is a chemical or biological hazard neutralized with five percent chlorine solution.

Note. A hard surface area is ideal for the location of a decontamination area as it allows for water runoff without creating a muddy surface; however, these materials (concrete or asphalt) will hold some agents for hours to days. Because of this, a PDS should not be set up on a hard surface road that will be needed later for vehicle movement.

5-166. Shuffle pits are not prepared when using a plumbed tent system. With these systems, decontamination team members remain inside the tent during operations so they do not track in contamination from the triage areas. Their boots can also be easily decontaminated inside the tent using the handheld sprayers if necessary.

5-167. A PDS with minimal equipment must prepare a shuffle pit at the hot line at the litter patient decontamination line, and another at the ambulatory patient decontamination line or one shuffle pit can be made for both litter and ambulatory lanes. Considerations for establishing a shuffle pit include:

- Both shuffle pits are located at and should straddle the hot line.
- The litter patient shuffle pit must be large enough to accommodate one litter and four personnel with enough space for them to move around the litter when placed on litter stands located inside the pit.
- The ambulatory shuffle pit must be large enough to accommodate two standing individuals.
- Each pit is dug to a depth of six inches. The soil is then returned to the pit and mixed with calcium hypochlorite at a ratio of three parts soil to two parts calcium hypochlorite. Personnel preparing the calcium hypochlorite/soil mixture must assume MOPP Level 4.
- If a boot rinse is used instead of a shuffle pit, then a plastic berm that can contain water is used. It is filled to at least five inches deep with a five percent chlorine solution. It should be replenished every five to ten patients. It should be large enough for decontamination team members to enter and place a litter patient on a pair of litter stands inside the boot rinse area and perform a litter transfer.

- Concertina wire or another barrier should be placed along areas of the hot line that do not include the shuffle pits. The shuffle pits should be the only areas along the hot line where the barrier can be crossed. This will ensure that movement across the hot line is controlled.

5-168. Only a portion of one MES needs to be moved to the triage area to meet the needs of the number of expected patients. During operations, additional medical supplies can be moved across the hot line from the clean side supply area as needed. This will reduce the possibility of unused supply items becoming contaminated resulting in their waste.

5-169. In a PDS with minimal equipment, the rest area is established in a shaded area on the warm side of the hot line, so PDS workers on the warm side of the hot line can rest, while at MOPP Level 4, without having to process across the hot line.

5-170. It is recommended that some type of marking system be incorporated to identify PDS workers. One suggestion is that all decontamination team members have their protective suit marked with wide colored tape that depicts the team they are on (for example, intake, triage, security, medical, or decontamination). Their name and or team member position (if colored tape is unavailable) should be clearly marked on their uniform so that they can be readily identified. Instead of tape, this can also be done by writing directly on the protective suit if it can be easily seen. If using tape or writing on the protective suit, ensure the information can be seen from the front and back so that team members at a distance so team members are easily identified. Another recommendation is for medical platoon personnel to wear an armband or have a tape cross on the arm of their protective suit.

5-171. Locate water resources, water cans, water buffalo, water bladder, or water tanker with easy access to the decontamination lanes.

5-172. In a PDS with minimal equipment, an ideal location will have containers of water that will be used for decontamination located near the warm side rest area. This will reduce any contamination of these containers. Other supplies can be located on the clean side of the hot line in the supply area. Ensure wastewater runoff from the decontamination lanes does not flow toward the water resource area or the medical treatment areas. Water usage can be roughly calculated as follows:

- One patient will require (on the average) 1.5 gallons (5.7 liters) of soapy water (or 0.5 chlorine solution, if used), 1.5 gallons of rinse water, and 2 gallons (7.6 liters) of water with 5 percent chlorine solution for equipment and decontamination team glove wipe down.
- One patient will require 5 gallons (18.92 liters) of water.
- Twenty patients will require 100 gallons (379 liters) of water.

5-173. Set up the water collection system, tentage, and plumbing as dictated by the manufacturer's instructions. Ensure that there is an adequate way to dispose of wastewater run-off, such as a water bladder, so that it does not contaminate the ground around the decontamination system. A water run-off gully (approximately 1 foot deep) or berm (approximately 1 foot high) can be constructed around wastewater bladders to

contain spills. If the run-off water poses a chemical or biological hazard, it can be neutralized with five percent chlorine solution.

5-174. To reduce cross contamination, fresh water and wastewater bladders must not be positioned next to one another. Ideally, they should be on opposite sides of the decontamination tent with the wastewater bladder downhill from the fresh water bladder and decontamination tent. It is critical that there is an easy access route for a water pumper truck to fill the clean water bladder and a route for a vehicle to pump out the contents of the wastewater bladder or for a forklift to move a specially designed transportable wastewater bladder (if used) to the back of a truck for movement out of the PDS.

5-175. Systems that incorporate water sprayers require a large water supply. The supply must provide enough pressure to operate the system. Water pumps are usually required and these require water sources. Ample water supplies are needed for expected number of casualties. A 2,000 gallon water storage container such as a tanker truck or water bladder, will allow the decontamination of approximately 200 patients. It is estimated that on the average 10 gallons of water is used per patient with these plumbed systems.

5-176. Operators must be aware of the importance of conserving water while still providing adequate decontamination. This will ensure that water supplies are not depleted and wastewater collection systems are not overwhelmed. Water can best be controlled by using handheld sprayers that will allow water flow to be turned off when not in use. Water flow should be adjusted to have moderate-to-low pressure with high flow for brief periods when the sprayer handle is pressed.

5-177. Ideally, units should incorporate a water heater to increase water temperature and reduce the incidence of patient hypothermia for those undergoing decontamination. Soap mixers can also be added which make dispensing soap from the sprayer possible. This is usually easier than using buckets of soap in the small confines of most tent systems. These heating and soap dispensing units, along with the water pumps, also require a power source.

5-178. Collection of contaminated wastewater is critical, especially for biological sporulating agents (anthrax) and radioactive particles. Wastewater collection is also important to limit runoff of soil and ground water contamination in the decontamination area, especially if the decontamination tent is close to the BAS. A wastewater bladder is used to collect the runoff. Wastewater is pumped from the collection area of the tent and into the bladder. In cold climates the water and wastewater bladder must be heated to prevent freezing. It is critical that the wastewater bladder be the same size, or larger, than the water storage source. For every patient decontaminated, calculate 10 gallons of wastewater runoff. Wastewater, once collected, is treated with five percent chlorine solution until chemical hazards are neutralized or biological spores are killed. Radioactive waste cannot be diluted in this way. One gallon of water weighs eight pounds, so a filled 2,000 gallon water bladder will weigh 16,000 pounds (eight tons).

Note. Premixed chlorine or soap solutions should be prepared in advance during site preparations and should be in sealed containers and clearly marked as to their contents. Five gallon covered water cans or larger jerry cans are ideal for this as they can be carried to a position near the decontamination line and used to refill pails/buckets.

CAUTION

Chlorine solution and soap solutions prepared in storage containers **MUST** be clearly marked as to their contents so that they are not mistaken for drinking water and five percent hypochlorite solutions are not confused with soap or chlorine solutions used for skin decontamination.

5-179. Open NATO litter carriers if available. These two-wheeled carriers allow two individuals to easily move a litter patient. They work well on hard ground but may pose difficulty in sand or uneven ground. Position several at the drop-off point and at least two at the clean side of the hot line (in the final check area).

5-180. When not setting up the decontamination site, medical platoon personnel can provide the nonmedical augmentees with additional just-in-time training on such topics as: basic medical signs and symptoms of chemical, biological, or radiological agents; safe patient litter transfer techniques; roles and responsibilities; the use of detection devices, the importance of work rest cycles; and prevention of heat injuries.

5-181. The allocation of decontamination equipment resources is suggested in tables 5-8 through 5-10 below and on page 5-52.

Table 5-8. Equipment and supplies needed for a decontamination lane

<i>Equipment and supplies</i>	<i>Nonambulatory</i>	<i>Ambulatory</i>
Large trash bags for contaminated waste.	1 box as needed	1 box as needed
Pail/bucket of decontamination, 5 percent chlorine solution.	1	1
Pail/bucket of decontamination, soap and water solution (0.5 chlorine solution [least preferred]).	1	1
Bandage scissors or long-handle seat belt cutter with blade replacements (minimum, more are needed as they dull).	4 +	4 +
Self-sealing plastic bags for tactical combat casualty care cards and for personal effects found in outer and inner garments.	1 box of 50	1 box of 50
Sponges.	2+	2+

Table 5-8. Equipment and supplies needed for a decontamination lane (continued)

<i>Equipment and supplies</i>	<i>Nonambulatory</i>	<i>Ambulatory</i>
Decontamination toxicological agent protective apron.	4	2
One decontaminable litter for exchange (per patient expected).	2+	
Reactive skin decontamination lotion (1 to 3 kits per patient).	1 box	1 box
M295 (1 per patient).	1 box	1 box
<i>Equipment and supplies</i>	<i>Nonambulatory</i>	<i>Ambulatory</i>
Liquid soap (mix in water storage area).	As needed	
Litter stands (pair).		1 to steady patients
Supplies to replace bandages, tourniquets, and splints (if necessary).	As anticipated	As anticipated
<i>Optional items not found in decontamination equipment set, but useful</i>		
Trash can to hold large garbage bags (if transport and storage space available).	1	1
Pail/bucket of rinse water.	1	1
Additional canteens of water for decontamination team members.	4+	4+
3 x 5-inch card and pen (to mark personal effects per patient) or permanent markers to mark outside of personal effects self-sealing plastic bags.	1 box	1 box
Chairs to steady patients while standing.	2	
Note. Additional quantities of soap and chlorine decontamination solutions must be prepared and stored in sealed containers to refill pails/buckets.		

Table 5-9. Equipment and supplies required for the contamination check area at a patient decontamination site with minimal equipment

Equipment and supplies	Per lane
Chemical and radiological agent detectors with batteries.	2
Spare lithium batteries.	8
Detection paper.	1 book
Reactive skin decontamination lotion for decontamination of small areas.	1 box
Bucket of soap and water for small area decontamination.	1
Sponge.	2

Table 5-10. Equipment and supplies required for the hot line at a patient decontamination site with minimal equipment

Equipment and sales	Per lane
Large trash bags for contaminated waste.	1 box
Book of tactical combat casualty care cards (on clean side of hot line).	1 book
Large plastic bag for patient's mask once removed at vapor control line.	1 box
Ballpoint pen (preferably black) to fill out clean tactical combat casualty care card.	As needed
Calcium hypochlorite to replenish shuffle pit.	1 container
Optional items not found in decontamination equipment set, but useful:	
Blankets (on clean side of hot line).	1 per patient
Trash can to hold large garbage bags (if transport and storage space available).	1

Actions to Take Upon Notification of Patient Arrival

5-182. Immediately upon notification that contaminated patients are to be received, the decontamination TL or NCOIC will alert the team members.

5-183. Patient decontamination site OIC/NCOIC will assign nonmedical augmentees to the decontamination team to perform their duties and responsibilities at the PDS.

5-184. All triage, EMT, and decontamination team members assume MOPP Level 2 when the arrival of contaminated casualties is expected, as dictated by the commander. They then assume MOPP Level 4 prior to patient arrival at the ECP. Those who will be decontaminating patients will don their TAP aprons. Mask carriers can be worn or clearly marked with the decontamination team member's name and stored in an organized fashion at the rest area or another location designated by the OIC/NCOIC. Mark protective suits with some type of marking system to easily identify PDS workers.

Turn on the Chemical Agent Detectors

5-185. The patient decontamination site OIC/NCOIC will assign nonmedical augmentee decontamination team members their duties and responsibilities at the PDS.

5-186. Once the alarm detectors are warmed up, perform confidence checks on each detector per the technical manual. Activate the chemical alarm detector system if available. It should be positioned at the vapor control line (VCL).

5-187. All decontamination team members on the warm, (dirty) side of the hot line, as well as those receiving patients on the clean side of the hot line, keep their protective masks on until all patients are decontaminated and the PDS area is determined to be free from hazardous vapors.

Actions to Take When Contaminated Patients Arrive

5-188. Security personnel in MOPP Level 4, at the ECP meet transport vehicles and ask the driver as to the numbers and types of casualties and the types of contamination if known. They relay this information by radio to the drop-off point and to PDS OIC/NCOIC. They then direct the vehicle to the drop-off point. For more information on triage see ATP 4-02.7/MCRP 3-40A.6/NTTP 4-02.7/AFTTP 3-42.3, chapter 3.

5-189. Patients are unloaded and, whether ambulatory or litter, are given a quick but thorough pat-down search for any ordnance or other explosive devices. The inside of mask carrier can also be checked. Weapons are removed and stored in an area on the dirty side of the hot line. These procedures can be performed by nonmedical augmentees designated as drop-off point security or by the nonmedical augmentees who are serving as litter bearers. Suggested pat down steps include:

- Remove the patient's weapons and load bearing equipment/load carrying equipment web gear.
- Check inside the patient's mask carrier for any munitions or unused autoinjectors.
- Try to keep the mask carrier with the patient for triage so that unused antidotes can be administered if nerve agent exposure is suspected or if the patient displays signs and symptoms of nerve agent poisoning.
- Move the hands down the patient's torso while feeling through the protective suit pockets for anything that could be ordnance. If ordnance (ammunition, grenades, magazines, or claymore mines) are found, remove them or alert the OIC/NCOIC according to unit SOP.
- Do not remove the patient's protective mask, the patient's personal items at this point, nor remove the patient's identification tags at any time while the patient is in the PDS.
- Bring the patient to the warm (dirty) side triage area after completing the previous steps.

5-190. The patient are now ready to be triaged and moved to a treatment area (immediate, delayed, minimal, and expectant) designated by the triage officer. All immediate patients are brought to the dirty EMT area for stabilization.

5-191. Those patients who need to see the medical providers inside the Role 1 BAS and are stable enough for decontamination are moved to the decontamination lanes by litter teams or, if ambulatory, directed by a nonmedical augmentee. The triage officer or EMT officer will direct patient priority for decontamination as follows:

- Patients requiring minimal care should remain on the dirty side of the hot line, remain in their protective ensemble, be treated there, and then returned to their unit without going through patient thorough decontamination and crossing the hot line.
- Only those patients needing care at this BAS should go through patient thorough decontamination.
- Patients with physical injury (that prevents them from going through the ambulatory lane) or that are mentally impaired (COSR) to the point where they are unable to walk or if they are unable to follow commands from the medical teams are automatically considered litter patients.

Actions Conducted at the Patient Decontamination Site

5-192. Detailed step-by-step instructions are included in ATP 4-02.7/MCRP 3-40A.6/NTTP 4-02.7/AFTTP 3-42.3, chapter 5. The medical platoon will use this chapter in developing internal SOPs used to execute the following:

- Moving a litter patient through a PDS.
- Transferring a patient to a litter.
- Removing clothing at the clothing removal station.
 - Litter patient mask, protective ensemble, and clothing removal procedures.
 - Ambulatory patient mask, protective ensemble and clothing removal procedures.
- Decontaminating the patient.
- Checking patient for completeness of decontamination.
- Moving the patient to the hot line.
- Moving the patient to the clean side of the hot line.
- Moving an ambulatory patient through patient decontamination.
- Processing through the ambulatory decontamination line.

Wound Decontamination

5-193. While nonmedical augmentees concentrate on patient decontamination, only trained medical platoon personnel will change or remove patient bandages, tourniquets, and splints.

5-194. During decontamination, the clothing around bandages, tourniquets, and splints is cut and, if possible, tourniquets and splints are left in place. If the patient is intubated, care should be taken to ensure the tube is not dislodged and respiratory care is assisted during the decontamination process.

5-195. Cloth or other debris in the wound can hold contaminants. If contaminated, irrigate large wounds with sterile water or IV saline solution to dislodge debris and wash out contaminants. Remove the debris using forceps (using no touch technique) or protective gloves. Preferably, it would be safer to use only instruments to remove objects from wounds. Sharp objects could potentially puncture or tear gloves. Then

cover the wounds with a large dressing and plastic if there is a fear of additional contamination getting into the wound.

WARNING

DO NOT apply reactive skin decontamination lotion or irrigate wounds in the abdominal and thoracic cavities or intracranial (head) injuries. DO NOT remove splints unless permitted by a physician or other medical platoon personnel under the supervision of a physician. DO NOT apply reactive skin decontamination lotion around eyes or other mucous membranes

Trauma Management During Decontamination

5-196. A contaminated tourniquet is replaced only by the medical platoon personnel. The new tourniquets are placed one inch proximal to the original tourniquet, and then the old, contaminated tourniquet is removed and put in the contaminated waste bag.

5-197. Chemically contaminated splints remain in place and are saturated to the skin with soapy water or 0.5 percent chlorine solution to include the padding and cravats. This can be performed by a decontamination team member if supervised by medical platoon personnel. If the splint cannot be saturated (air splint or canvas splint), it must be removed or replaced by a physician or by other medical platoon personnel under the supervision of a physician to enable everything under it to be decontaminated.

5-198. Removal of IV bags and tubing during decontamination is at the discretion of the medical officer supervising decontamination operations. The IV bags can be wiped down with soap and water if there is a concern about their contamination. If necessary, the bags may be discarded and exchanged. The IV lines should be protected during the decontamination process and during patient litter transfer.

5-199. In severe cases, intubation may be required to ensure patient airway, improve oxygenation, and aid in removal of secretions. Endotracheal tube can be wiped down with soap and water if there is a concern about their contamination. The endotracheal tube should only be removed by medical platoon personnel. If necessary, the bag valve mask/manual resuscitator may be discarded and exchanged.

CORE COMPONENTS OF THE PATIENT DECONTAMINATION SITE AND PATIENT FLOW

5-200. All operating forces and all roles of medical care use a similar patient flow during patient decontamination operations. Each Service may use different types of equipment and procedures. Listed below is an overview of 18 core components found within the PDS (refer to ATP 4-02.7/MCRP 3-40A.6/NTTP 4-02.7/AFTTP 3-42.3, chapter 5 for detailed information on each component area).

5-201. When establishing a PDS, all component areas noted in this section should be considered and addressed (see figure 5-4).

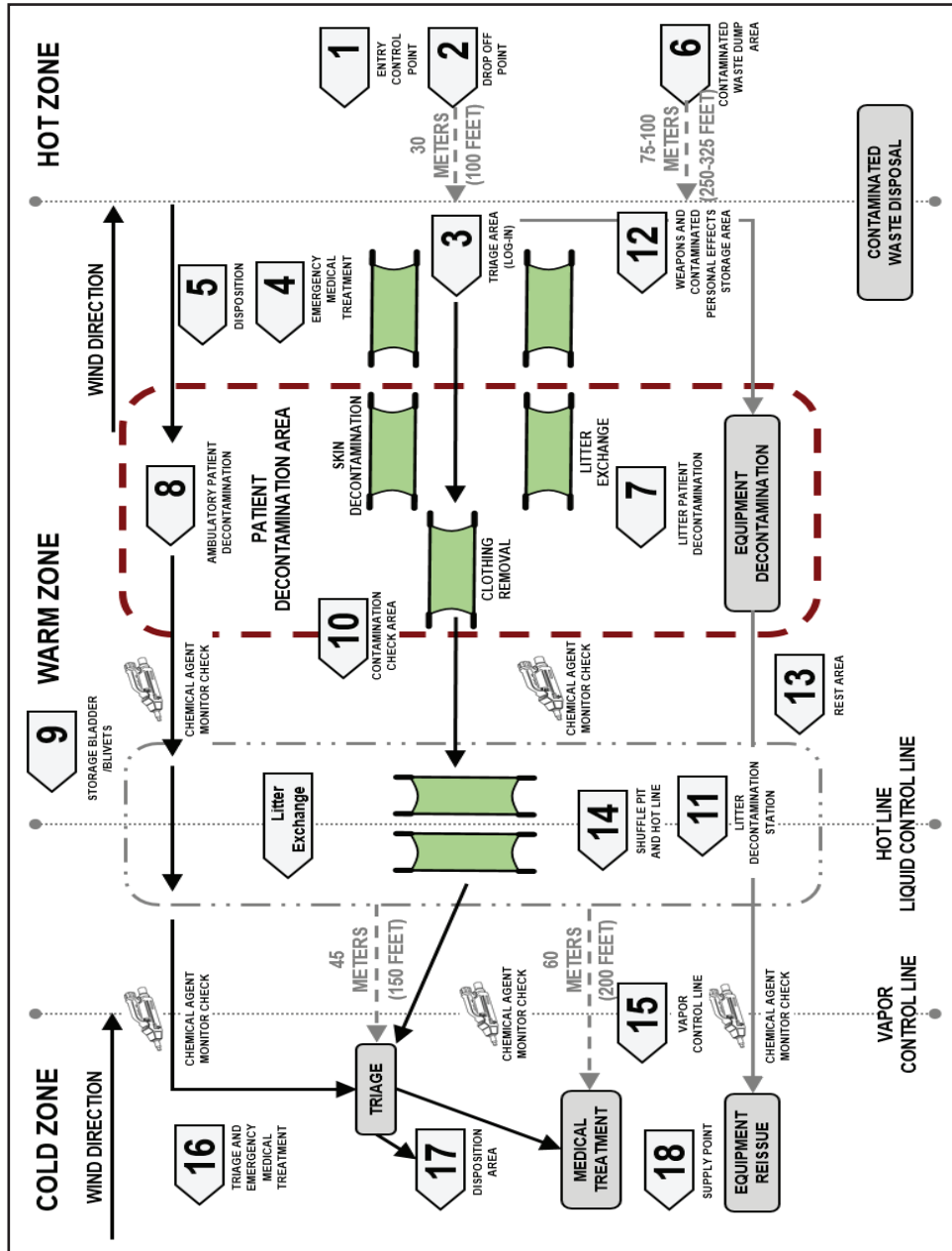

Figure 5-4. Patient decontamination site component areas

ENTRY CONTROL POINT AND DROP-OFF POINT (1 AND 2)

5-202. Entry control point and drop-off point is an area downwind from the triage and decontamination areas. This is where patients arrive at the PDS. On land, this incorporates road access for evacuation vehicles as well as MEDEVAC rotary-wing landing areas. Rotary-wing LZ should be located 45 to 60 meters (150 to 200 feet) away from the ECP to protect patients and decontamination personnel from small objects propelled by the rotor blade upon landing. These avenues must be organized so that smooth traffic flow occurs during patient drop-off.

Entry Control Point (1)

5-203. The entry control point is located along an access road to the drop-off point. Security must be provided to control access to the PDS. Security personnel must meet vehicles upon arrival, quickly interview drivers/escorts, and get information from the drivers/escorts as to the number of patients, types of injuries, and types of contamination, if known. They relay this information by radio to the drop-off point and PDS OIC/NCOIC.

Drop-off Point (2)

5-204. The drop-off point is where patients are off loaded from vehicles and brought to the triage area. The drop-off point is staffed by nonmedical augmentees who direct traffic flow, unload vehicles and move patients to the triage area, remove patient weapons and equipment, and perform quick pat down searches of patients.

5-205. If adequate chemical and radiological monitoring devices and trained staff are available, a monitoring station can be set up at the drop-off point to determine who are contaminated and require decontamination. Personnel at the ECP and drop-off point assume MOPP Level 4 when contaminated patients are expected.

WARM ZONE (DIRTY SIDE) TRIAGE AREA (3)

5-206. The triage area is located near the drop-off point in the PDS warm zone. Patients are moved to this area from the drop-off point.

5-207. Patients are simultaneously triaged based on their need for medical care, their priority for patient thorough decontamination, and their priority for evacuation to the next role of care. One patient may be medically triaged as immediate but not have priority for decontamination until they are medically stable. Another may have priority for MEDEVAC but requires decontamination.

5-208. This area should initially be large enough to allow for an influx of many patients. The triage area is located adjacent to or can be collocated with the warm side (dirty side) EMT area.

5-209. Within the triage area, casualties are moved to either the immediate (warm side, dirty, EMT), delayed, minimal, or expectant treatment areas. A patient is retriaged as their condition changes. The following is suggested as a placement for specific treatment areas to improve patient flow through the PDS:

- The immediate category patients are moved to the warm (dirty side) EMT area. This area is located between patient triage (closer to triage area to minimize the time it takes to move from triage area to dirty EMT) and the entrance to the litter patient decontamination lanes. This way they can be moved to litter decontamination without interfering with the traffic flow from other patient categories.
- The delayed patient area should be positioned near the entrance to both the litter and ambulatory decontamination lines. This way delayed patients can be processed through either the litter or ambulatory lanes when the lanes become available.
- The minimal category patients should be positioned near the ambulatory patient area so that if medical care on the clean side of the hot line is needed they can process through the ambulatory lane when it becomes available and will not interfere with the flow to the litter lanes.
- The expectant category patients should be located near the EMT area, but farther away from the decontamination lanes, so that they can be retriaged and stabilized for decontamination if the EMT area no longer has patients in it. The expectant patient should not be abandoned, but should be separated from the view of other casualties.

5-210. Casualties are retriaged as they progress through the EMT and decontamination process. Personnel in the triage area wear MOPP Level 4. One triage officer, but preferably two or more (if available), is assigned to this area and the triage officer, regardless of area of concentration, should be trained in triage. These are typically experienced medical platoon personnel. A discussion of medical triage and treatment protocols for CBRN casualties can be found in ATP 4-02.85/MCRP 3-40A.1/NTRP 4-02.22/AFTTP(I) 3-2.69 for chemical casualties; ATP 4-02.84/MCRP 3-40A.3/NTRP 4-02.23/AFMAN 44-156_IP for biological casualties; and ATP 4-02.83/MCRP 3-40A.2/NTRP 4-02.21/AFMAN 44-161(I) for radiological/nuclear casualties.

WARM SIDE (DIRTY SIDE) EMERGENCY TREATMENT AREA (4)

5-211. Patients triaged as immediate for medical treatment are sent to the warm side (dirty) EMT until their condition is stabilized for patient thorough decontamination or stabilized for dirty evacuation to another role of care medical unit. This area should be located between the patient triage and the entrance to the litter decontamination lanes.

5-212. An initial quantity of medical supplies is located in this area, and procedures for resupply must be established. It is important to only put enough supplies here for the anticipated number of patients so that unused supplies are not in danger of becoming contaminated.

5-213. The warm side EMT area should be large enough to expand and handle an influx of patients. Personnel in the warm side EMT area assume MOPP Level 4. Two or more trained medical platoon personnel are assigned to this area to triage patients and provide lifesaving medical care while wearing protective ensemble. Staffing should consist of trained and experienced medical platoon personnel (field surgeon, PA, or combat medic).

WARM SIDE DISPOSITION (DIRTY EVACUATION) (5)

5-214. This is an area located in the vicinity of the warm side EMT area.

5-215. Patients who require rapid evacuation to another role of care and who have undergone operational decontamination are medically stabilized and staged for pick up and transport by designated dirty evacuation assets (ground, water, or rotary-wing aircraft) are located here.

5-216. Gross contamination is removed from their protective ensemble before being loaded onto the designated dirty evacuation vehicle.

CONTAMINATED WASTE DUMP AREA (6)

5-217. This area is located away from the decontamination area and clean areas. On land, it is at least 75 meters (250 feet) downwind from the drop-off point. Bags of contaminated clothing and bandages are taken to this area.

5-218. Contaminated waste is buried and marked with the appropriate hazard markers. The locations are marked on maps and communicated to headquarters so that the waste can be picked up and properly disposed of. These locations should be guarded to prevent looting of hazardous waste materials by locals who are not aware of the hazards. This may not be possible on the fluid battlefield.

LITTER PATIENT DECONTAMINATION LINE (7)

5-219. This is an area located between the warm side EMT and the hot line. Discussed below are tasks medical platoon leadership should plan for:

- Patients must be medically stable enough to undergo decontamination before they are brought to the litter patient decontamination area.
- Litter patient decontamination lanes are established in this area. Ideally, more than one litter patient decontamination lane should be established depending on the number of patients expected.
- Personnel assigned to this area assume MOPP Level 4. Those performing decontamination also wear a TAP apron over their protective ensemble to keep their protective ensemble dry and to allow them to decontaminate their aprons before conducting patient transfers. This area is manned by nonmedical augmentees who are closely supervised by medical platoon personnel.

AMBULATORY PATIENT DECONTAMINATION LINE (8)

5-220. The ambulatory patient decontamination line is where ambulatory patients go to be decontaminated. This area is usually located parallel to the litter patient decontamination line:

- Ambulatory patients who need to see the field surgeon or PA at the BAS are processed through this area.
- Patients who can be treated in the warm side EMT area and then sent back to their unit should not go through ambulatory patient decontamination.

- Ambulatory individuals who do not have medical complaints should be processed through troop decontamination lanes and not through the medical ambulatory decontamination lane.
- Medical and decontamination team members can be processed to the clean side through this area or processed through troop decontamination, if it is collocated.
- Personnel assigned to this area assume MOPP Level 4. Those performing decontamination also wear a TAP apron to keep their protective ensemble dry. This area is usually manned by nonmedical augmentees and at least one member of the medical platoon if available to supervise ambulatory patients as they process through the line and assist one another.

CLEAN AND WASTEWATER STORAGE BLADDERS (9)

5-221. Clean and wastewater storage bladders are only used for a PDS with plumbed tentage and shower systems. The bladders are located in the proximity of the decontamination tent. The PDS must be located in areas where the bladders can easily be accessed by vehicles to fill the clean bladder and pump out or pick up and transport the wastewater bladder. The clean and wastewater bladders must not be located next to each other, but ideally should be on opposite sides of the tent. The wastewater bladder must be located as far away from the tent if possible.

CONTAMINATION CHECK AREA (10)

5-222. The contamination check area is located between the decontamination lines and the hot line. Here, thoroughness of decontamination is checked for chemically and radiologically contaminated patients using the appropriate monitoring devices. Self-sealing plastic bags containing the patient's personal items can also be unzipped and the monitors used to check for contamination of the items inside them. If the items are contaminated, they can be decontaminated and placed in a new bag once they are determined to be free of contamination, or contaminated items can be bagged and sent to a secure holding area for later disposition.

5-223. The station can be set up between the litter patient and ambulatory patient decontamination lines if detectors and those trained to use them are in limited supply.

5-224. Locating this station inside a plumbed decontamination tent may pose challenges as the spray inside these tents will often create some aerosolization of any agent causing the detector alarm to activate.

LITTER DECONTAMINATION STATION (11)

5-225. For the decontamination operation with minimal resources, the litter decontamination station is located on the dirty side of the hot line. It is located where warm side litters are washed and readied for use by new patients. Buckets and sponges with five percent chlorine solution are available, as well as water to rinse the litters. With a shower/roller system litter decontamination may only entail sending the litter back through the decontamination station for a wash.

WEAPONS AND CONTAMINATED PERSONAL EFFECTS STORAGE AREA (12)

5-226. This is a guarded area where weapons and patient personal effects are secured and inventoried. This is located on the warm side of the hot line. Items from this area are moved through the contamination check area and decontaminated as needed before being moved across the hot line. If personnel are limited, this area may need to be closely monitored under the observation of personnel serving as security augmentees.

WARM (DIRTY) SIDE REST AREA (13)

5-227. This area is located on the warm side of the hot line. This should be a shaded area (for example, trees, a building, or tentage). The PDS team members can rest and drink water in this area while remaining in their protective ensemble. The warm side water point is located here. Water that will be used for decontamination can be stored here so that it is out of the way of the areas of greatest contamination (drop-off point, dump, and decontamination lines) but still accessible to decontamination team members.

HOT LINE AND SHUFFLE PIT (14)

5-228. This is the line that separates the PDS warm zone (dirty side) from the cold zone (clean side) where the Role 1 BAS is located. No liquid or solid contamination crosses the hot line. The line must be indicated in some way (such as by a barrier, tape line, or airlock) so that all personnel know not to cross the line unless they are properly decontaminated. It is best to indicate this area with a specific barrier, such as concertina wire, to protect the BAS.

5-229. A shuffle pit or boot rinse is located at the hot line to ensure that footwear worn by individuals working in the shuffle pit area is decontaminated. A shuffle pit with a sand hypochlorite mixture is only used for a PDS with minimal equipment and is only useful when chemical or biological contamination is evident. A boot rinse can be used with a plumbed decontamination tent with sprayers. The hot line may also be referred to as the liquid control line.

5-230. At the hot line, information on the patient's DD Form 1380 is transferred to a clean card, and litter patients are transferred to a clean litter to ensure that contaminated DD Form 1380s or litters do not cross the hot line. Litters used on warm side of the hot line will stay on the warm side, and those used on the cold side of the hot line stay on the cold side.

5-231. Team members on the warm side of the hot line are the decontamination team members who have decontaminated the patient. They will bring the patient to the hot line from the warm side. They are still wearing their protective ensemble with TAP aprons. The patient is received on the clean side of the hot line by a team of at least one medical platoon personnel and two nonmedical augmentees. They take the patient from the decontamination team while trying to avoid physical contact with the warm side decontamination team members. Those assigned to the clean side of the hot line should be at MOPP Level 4 but do not require TAP aprons.

VAPOR CONTROL LINE (15)

5-232. This is a line that encompasses the warm zone and is also located between the hot line and the clean side triage area and Role 1 BAS. It is typically just upwind of the hot line by 10 meters (32 feet). Patients and PDS team members remain masked until they cross this line. This line can be established using chemical vapor detectors. A VCL is not needed for a radiological and biological agent hazard as there are no hazardous vapors from these agents.

TRIAGE/EMERGENCY MEDICAL TREATMENT AREA (COLD ZONE) (16)

5-233. This is an area beyond the hot line and VCL where patients are retriaged and treated before entry or movement to the Role 1 BAS. All patients entering this area are free of contamination. With large numbers of patients, this can be a holding and staging area for admission to a BAS for clean evacuation to another BAS, or for ambulance transport from a collocated decontamination area for a nearby BAS. Personnel assigned to this area do not need to wear protective equipment. The staff should protect themselves from infectious patients by practicing standard precautions and wearing appropriate respiratory protection to protect against infectious particles from coughing or sneezing patients.

DISPOSITION (COLD ZONE/CLEAN EVACUATION) (17)

5-234. This is an area adjacent to the cold zone triage/EMT area. Patients who have been decontaminated and stabilized can be staged for transport to another treatment facility. Personnel assigned to this area do not need to wear protective equipment unless standard precautions are required to protect them from infectious biological hazards however, periodic monitoring for hazards still need to occur.

CLEAN SIDE SUPPLY POINT (18)

5-235. The clean side supply point is located on the clean side of the hot line, outside of the VCL. The PDS supplies are kept here and are handed across the hot line to the warm side when needed. This provides protection to PDS supplies and limits exposure to possible contamination. This area should be covered from the elements and protected in the event of CBRN attack or a wind shift from the battle area. Clean side water storage can also be located here for easy movement in water cans across the hot line.

TEMPORARY MORGUE (19)

5-236. Temporary morgues are located on the dirty and clean sides of the PDS for patients who died of wounds while going through the decontamination process at the PDS (as a temporary holding area, it is not depicted in figure 5-4 on page 5-56). Supported units do not bring their dead to this area. This is only for the temporary storage of the human remains of those who died of wounds. This should be in a cool shaded area away from the triage area (dirty and/or clean triage areas). The following steps should be taken when placing human remains in the temporary morgue:

- The Soldier assigned unit should be notified as soon as the contaminated human remains are placed in the temporarily established morgue.

- Tag the contaminated human remains with a DD Form 1380.
- Secure the contaminated human remains by placing them in a human remains pouch. If the human remains pouch is not available at the PDS, contact the unit logistics staff to acquire it.
- The contaminated human remains will remain in the temporary morgue and handled according to theater policy until they are retrieved by the Soldiers' unit, transportation is coordinated for transfer of the human remains to a mortuary affairs collection point (either contaminated or non-contaminated collection point) or mortuary affairs personnel.

Biological Hazards

5-237. Human remains inherently have the potential to release transmissible disease agents in a viable form in blood, body fluids, feces, or gastrointestinal contents. Established procedures and universal/standard precautions PPE are designed to mitigate such risks. However, additional safety precautions and PPE for potentially released internal fluids are especially necessary for certain highly infectious, easily transmissible pathogens for which effective treatment and preventive measures are not usually available (such as certain hemorrhagic fevers, Ebola, or Marburg). For a complete list of such agents, refer to the World Health Organization Risk Group IV agents (the list can be found at the Centers for Disease Control and Prevention website). Certain CBRN scenarios that involve the intentional release of a persistent aerosolized biological agent may have the added consideration of the external biological hazard on clothing, skin, or hair. This may be a concern particularly if there is concern of reaerosolization—for example, in the event of an aerosol release of anthrax spores or toxins.

Chemical Hazards

5-238. The hazards associated with chemical releases are primarily linked with the potential for residual external contamination (for example, on clothing, skin, and hair). This is a concern for chemical agents that are considered persistent (such as chemical agents that have low volatility and can remain present at hazardous levels for several hours or days). Examples include blister (vesicants) agents (such as sulfur and mustard), and nerve agent (VX and Novichok). Nonpersistent agents are typically released as a vapor and dissipate/volatilize quickly so the hazard is mitigated without the need for decontamination or verification. Examples include many high vapor pressure toxic industrial chemicals of military concern, such as chlorine gas, as well as highly volatile chemical warfare agents such as sarin. Human remains removed from a CBRN environment involved in the release of nonpersistent chemical release generally should not be considered contaminated unless unique circumstances warrant specific precautions (such as extremely concentrated exposures including liquid contact, and/or cold temperatures that may slow down the volatilization processes).

Radiological Hazards

5-239. Determination of the degree of contamination risk, appropriate personal protective measures, and other control measures depend on radiation type, dose and dose rates. These determinations should be verified through use of appropriate radiation instrumentation, dosimetry, and technical subject matter experts whenever possible.

Internal radiation exposure (generally caused by inhalation or ingestion) will likely pose little health risk to persons exposed to the human remains. External contamination can be mitigated by removing clothing and washing the skin.

PATIENT DECONTAMINATION OPERATIONAL CONSIDERATIONS

5-240. Listed below are topics the medical platoon must consider when it conducts patient decontamination operations.

NIGHT OPERATIONS

5-241. Night operations make patient movement through a PDS more challenging because of the visual limitations imposed by darkness. Floodlights will typically not be appropriate in a battlefield situation where blackout conditions are imposed to limit tactical vulnerability. Safety and site organization will be critical to successful operations. Blackout conditions will definitely place limits on the following:

- Safe movement of patients and personnel in the area of the drop-off point.
- Safe movement of litter crews through patient triage and treatment areas.
- Ability of medical platoon personnel to visualize patient medical signs which is already made difficult where patients are in protective ensemble.
- Ability of decontamination team to see what they are doing during patient decontamination.
- Movement of ambulatory patients through the decontamination process.

Reducing the Risk of Accident During Night Operations

5-242. To reduce the incidence of accident the following measures are suggested:

- Set up the decontamination site during the day, with the aim of having its lay out simple enough and well understood so that it can be used just as well at night.
- Mark lanes for movement from the different triage areas with cloth tape, caution tape, or other markings at waist height, so that litter teams will know where to go.
- Clear routes through the PDS of debris and holes.
- Flashlights (with red lens filters) are available at the arrival point, triage area, treatment areas, decontamination lanes, and hot line.
- Name and decontamination team member job are clearly marked on operators in colored tape or large letters on tape, which is on the front and back of their protective ensemble.
- Voice amplifiers are on all operators' protective masks.
- Chemical lights and/or construction tape is placed at waist level to mark travel routes within the decontamination site.
- Night vision devices are provided to personnel at the drop-off point so they can identify approaching vehicles.

- Vehicle off-load procedures are briefed and patients are moved out of the drop-off point before off-load vehicles are allowed to move again.
- Ground guides of wheeled vehicles are allowed to move in the drop-off point and speed limits of five miles per hour (walking speed) is enforced.
- Concertina wire is marked with chemical lights, especially along the hot line, to prevent accidental movement into the wire.
- Patient movement and processing is rehearsed while there is still sunlight.

Activities During Night Operations

5-243. For safety and for ease in conducting activities during night operations, below are some considerations to follow.

Entry Control Point

5-244. Attach the chemical light to the front end of the vehicle (below the level of the hood), to prevent its interference with the driver's night vision.

5-245. The individuals manning the ECP should be equipped with a radio, a pair of binoculars, and night vision goggles for standoff inspection of the approaching evacuation vehicle.

5-246. Once the vehicle halts at the ECP, the ECP personnel should conduct a cautious approach of the vehicle. They should note the MOPP level the evacuation vehicle crew is in and, regardless of MOPP level, question the crew about the number and types of casualties they have and what type of agent the patients were exposed to if they know.

5-247. Individuals manning the ECP use detection paper or tape to make a rapid and accurate determination of whether or not a liquid chemical agent is present on or in a vehicle. Use the chemical agent detector/monitor to identify vapors coming from any liquid contamination on or in a vehicle. Visually inspect the vehicle at the ECP and test any suspect liquids on the vehicle with detection paper. Areas likely to have liquid contamination are the vehicle's wheel well areas, tires, and rear portion of the vehicle.

5-248. Information is relayed from the ECP (preferably by radio) to the decontamination OIC or NCOIC. The personnel manning the ECP are in MOPP Level 4. The OIC or NCOIC informs the triage officer and others at the PDS as well as those at the receiving Role 1 BAS. Knowing the agent can help medical providers better focus their care. It will also help the decontamination team members to know if they need to remain at MOPP Level 4.

5-249. Litter teams may be utilized to transfer casualties from the ECP to the arrival point, but this is highly labor intensive and not recommended. The contaminated evacuation vehicle may be routed into the drop-off point on a route that has minimal impact on other vehicle movement into the area.

5-250. Ground guides meet vehicles at the ECP that are traveling to the drop-off point. The guides must be equipped with red lens flashlights. Litter bearers (if adequate numbers are available), can serve as ground guides or assistant vehicle commanders can be asked to perform this function. Ground guides will walk no more than five meters (16 feet) in front of the vehicle. Every vehicle must have a ground guide at night. Speed

limits of five miles per hour (walking pace) must be enforced so that personnel are not run over by vehicles.

Triage and Treatment Areas

5-251. Patients are off-loaded from the ambulances, given a pat-down search, and taken to the triage point. The patients are triaged and visibly marked with prepared tags, or adhesive tape. It is important to remember that triage categories will change as the patient processes through the PDS. Colors that can be used to denote the patients current medical triage category are:

- Immediate – Red
- Delayed – Yellow
- Minimal – Green
- Expectant – Black (blue chemical light during hours of limited visibility)

5-252. The use of these colors can extend into night operations with the use of chemical lights of the same colors, with the exception that the expectant patient would be marked with a blue chemical light.

5-253. The triage area will also need to be marked with the above mentioned chemical lights, appropriate for the triage category and attached to engineering tape. Medical platoon personnel must be equipped with red-filtered flashlights. Nonmedical augmentees may need to assist medical platoon personnel by holding lights while they work.

Decontamination Lanes

5-254. Site preparation will require time for shuffle pit preparation, dirty dump preparation, and removal of any ground obstacles. If there is time to accomplish any of this labor-intensive work prior to activating a PDS, it will greatly improve PDS operations.

5-255. If preparation prior to actual use cannot be done, at the very least a ground reconnaissance must take place prior to site activation. All vehicle movement routes must be marked, points along the route requiring direction indicators identified, and any ground obstacles identified for removal.

5-256. Both the litter decontamination and ambulatory decontamination areas must be surveyed to ensure ease of movement for litter teams and for decontamination and medical platoon personnel. The ambulatory decontamination area must be evaluated for direction indicators that might facilitate easy movement of ambulatory patients through the various steps and likewise for any obstacle that might impede foot traffic.

Personnel Requirements

5-257. Night operations will require additional personnel to fill such jobs as ground guides and individuals to assist medical platoon personnel by holding red-filtered flashlights during triage and emergency procedures in the dirty side triage and EMT areas.

COLD WEATHER OPERATIONS

5-258. While it is difficult to deploy many chemical warfare agents during cold weather, they can be formulated to exist as liquids at cold temperatures presenting primarily a liquid or frozen liquid hazard as opposed to a vapor hazard. As the liquid contaminated individual is moved into a warm environment, liquid agents may begin to present more of an off-gassing hazard. Radiological particles present a hazard at any temperature. In cold temperatures, biological agents present only a limited hazard, though sporulating agents can still be hazardous if inhaled. Cold temperatures greatly increase the risk of patient cold shock and hypothermia. Patients who are medically compromised because of blood loss, exposure to a chemical agent, or severely ill from a biological or radiological exposure have little energy reserve to maintain their core body temperature, and therefore, they are more susceptible to developing hypothermia.

Cold Temperature Challenges

5-259. Any environment where the ambient air temperature drops below 65°F (18°C) can present a chill hazard to the medically compromised patient and creates an environment where the use of unheated water for outdoor decontamination is perceived as very uncomfortable by most individuals. A fall or winter climate will present a challenge as well as desert environment that can become very cool once the sun sets. Rainy climates can pose a temperature hazard for patients as well as air-conditioned decontamination tents which allow workers longer work cycles but can create an environment that may be very cool for the medically compromised patient. Medically compromised patients, such as those affected by a significant nerve agent exposure or blood loss, have a greater chance of developing hypothermia, especially in cooler climates.

Protecting Decontamination Team Members

5-260. While the risk of heat injury is greatly reduced for the decontamination team members wearing full protective ensemble, heat injury can occur if individuals wear excessive thermal undergarments under their protective ensemble and do not anticipate the heat that their bodies generate once they begin to work.

5-261. While protective ensemble will offer some warmth, it is not sufficient to keep an individual warm in colder climates. Wearing a complete uniform under the protective suit will increase the insulation effect. Thin long underwear that can wick sweat away from the body can also help when temperatures go below 30°F (-1°C). Keeping active also warms the body.

5-262. Decontamination team members should layer clothing under their protective ensemble so that it can be removed if needed. It is best to have a warming tent on the warm side of the hot line where decontamination team members can warm themselves when needed. If a heated warming tent is not available, blankets should be available for staff in the rest area. Just as rest breaks to cool individuals are needed in warm temperatures, rest breaks to warm workers are needed in cold climates.

Note. Team members should train at various temperatures to gain a better understanding of the amount of layered under-clothing that is appropriate for their work level at the PDS so that they are not overheated while working.

5-263. Wool glove liners can be worn under protective gloves in freezing climates. In any cool condition, the cotton liners should be worn under the protective gloves to help insulate the hands. Wearing wool or cotton glove liners will reduce the individual's tactile sensation at the finger tips, but the team member's hands must be safeguarded as protective gloves offer no insulative properties against the cold.

5-264. If possible, heated triage and treatment tents or heated buildings should be used. This will reduce both staff and patient exposure to the cold. If contaminated clothing worn by patients has not been removed prior to their being brought into these areas, the areas must be well ventilated so hazardous chemical vapors do not build up inside the enclosed space. Ideally, patient clothing should be removed just inside or outside the entrance to these facilities.

5-265. In a cold environment, individuals may not feel as thirsty as they would in warm weather. They will fail to drink the amount of water they need and will then become dehydrated. The recommended daily water intake per individual is from three to six quarts (three to six canteens).

5-266. At freezing temperatures, slips, trips, and falls on ice can pose a real hazard to patients and decontamination team members, especially around decontamination tents where chlorine solution, soap, and water is used. Rock salt or similar material should be carried to place on ice patches around decontamination tents.

Cold Shock

5-267. This is a patient's sudden physiological response to cold which can rapidly elevate blood pressure and can result in sudden death in susceptible individuals. The risk is greater for those with preexisting heart disease and the aged. Cold shock can be minimized by inquiring about preexisting medical conditions before decontamination. Encouraging patients to gradually get wet, rather than suddenly stepping into a cold stream of water, or by ensuring that water used for decontamination operations is adequately heated can help prevent cold shock.

Hypothermia

5-268. This is a condition of deep body cooling that usually takes longer to develop than one would normally encounter during decontamination operations. Most individuals can tolerate 55° Fahrenheit (13° Celsius) water but will experience discomfort and shiver severely. This may, however, impact an individual who is already medically compromised. Shivering becomes the source of self-generated heat for people who are exposed to the cold. A cold and shivering individual is generating body heat, and this in and of itself is not a sign for alarm. Blood that circulates through the head, arms, hands, legs, and feet cools near the skin surface and will eventually cool the core of the body over a period of time which can lower the core temperature to dangerous levels. The body's vasoconstriction slows heat loss through this process to some degree.

Every effort should be made to reduce the amount of time that a patient is exposed to the cold to conserve the patient's body heat and maintain their core body temperature and energy. A simple way that medical platoon personnel can assess if a decontaminated patient is experiencing hypothermia is for the medical platoon personnel to place an ungloved hand on the chest or back of the patient. If the skin feels warm, then hypothermia is unlikely. Core temperature is more accurately measured with a hypothermia assessment thermometer which is inserted rectally and can read as low as 70° Fahrenheit (23° Celsius).

5-269. Mild hypothermia is characterized by shivering and the person may report that they feel cold and may have goose bumps on the skin. Individuals may not be able to perform fine motor tasks with their fingers, such as buttoning a button.

5-270. In moderate hypothermia individuals may be ill tempered and slow moving. They may stumble, slur their speech, shiver intensely, not be able to use their hands effectively, and act inappropriately. Shivering stops when the body core temperature decreases to 86° Fahrenheit (30° Celsius).

5-271. Severe hypothermia is a life threatening situation where the core body temperature has reached dangerously low levels. There is a lack of shivering, unresponsiveness, pupil dilation, and cloudy consciousness. The person may be unable to move. If not warmed immediately, the individual will progress to respiratory failure, cardiac arrest, and death.

Note. Every effort should be made to reduce the amount of time that a patient is exposed to the cold during decontamination to conserve the patient's body heat, to conserve energy, and to maintain core body temperature.

Use of Detectors in Cold Weather Operations

5-272. Chemical vapor detectors will not work effectively in cold weather as agents give off few vapors in cold climates. The life of the battery is also significantly reduced, especially at temperatures below freezing.

5-273. Radiological survey equipment/detector will still be effective in colder climates. However, response time may be longer and battery strength will be impacted.

5-274. In freezing climates, chemical vapor detectors can be placed in rest tents that are warm to measure any vapors in these areas.

Patient Decontamination Strategies for Cold Weather Operations

5-275. One method for the selection of appropriate cold weather decontamination is based on ambient temperature. The closer the ambient temperature is to freezing, the more patient operations are conducted inside a heated enclosure.

5-276. Regardless of the ambient temperature, individuals who have been exposed to a known life-threatening level of chemical contamination should disrobe, undergo decontamination, and be sheltered as soon as possible. Refer to table 5-11 on page 5-70 for decontamination methods based on ambient temperature.

Table 5-11. Decontamination methods based on ambient temperature

<i>Method</i>	<i>Temperature (typical)</i>	<i>Warm side triage and treat</i>	<i>Clothes removed</i>	<i>Decontamination water temperature</i>	<i>After decontamination patient moved to</i>
1	65°F (18°C) and above	Outside	Outside	Decontamination outside	Outside clean side triage area
2	36°F (2°C) to 65°F (18°C) and above	Outside	Outside	Decontamination outside	Heated clean side triage area
3	35°F (1.6°C) and below to 64°F (17°C)	Outside	Inside	Heated decontamination enclosure	Heated clean side triage area
4	35°F (1.6°C) and below	Inside	Inside	Dry decontamination (flour, sand, paper towel, reactive skin decontamination lotion) for immediate decontamination	Transport to indoor heated decontamination area, preferably in a building
<p>Note. Method 1 is the easiest, and Method 2 is the most complex. Gray areas are where activities are performed inside a heated enclosure. Adapted from Guidelines for Cold Weather Mass Decontamination During a Terrorist Chemical Agent Incident, SBCCOM, August 2003.</p>					
<p>Legend: C Celsius F Fahrenheit</p>					

PROCEDURES FOR CLOSING DOWN A PATIENT DECONTAMINATION SITE

5-277. Once all patients have been processed through the PDS, the OIC will direct the team members to close down the PDS or disestablish it if it needs to be moved to a new location. The closure of the PDS will pose challenges due, in large part, to the fatigued condition of the PDS personnel. During PDS closure, it is critical that PDS personnel maintain adequate water intake so that workers do not become dehydrated. See table 5-12 5-71 for equipment needed for the closure of a PDS.

5-278. Medical team members from the triage area will begin PDS closure procedures first, as their portion of the process ends first. They consolidate unused, but uncontaminated, medical supplies and place them in their appropriate containers/boxes. These must be checked with the appropriate monitoring device before consolidation so that other supplies are not cross contaminated. All waste materials are placed in contaminated trash bags and sealed by double knotting the necks of the bags. The bags are then transported to the dirty dump in appropriate MOPP level. The drop-off point personnel will also assist with this effort. Any contaminated medical supplies that cannot be decontaminated will be placed in the contaminated trash bags and discarded in the dirty dump.

5-279. Supplies and equipment that can be decontaminated will be sent through the decontamination line either on a backboard or litter. If the PDS is not going to be relocated, these items can be stored in the shade on the warm side of the hot line after they have been decontaminated.

5-280. All cutting devices are allowed to sit in a bucket of five percent chlorine solution (if chemical or biological agents were encountered) for 30 minutes and then rinsed thoroughly if they are to be reused. If radiological contamination was encountered, cutting tools only need to be rinsed thoroughly. Blades are then replaced if they are to be reused. Dull bandage scissors or other cutting devices are bagged with other waste and sent to the dirty dump.

5-281. Any weapons or patient personal effects which have not been decontaminated by this time are decontaminated, checked for contamination, and passed across the hot line. Personal effects that cannot be decontaminated, such as paper items, are also placed in the contaminated trash bags and disposed of in the dirty dump.

5-282. Once all supplies and equipment have been stored and washed, the inside walls of the roller system decontamination tent should be sprayed down with soapy water and then rinsed.

5-283. Arrangements should be made to have the water containers topped off and the wastewater containment neutralized and emptied or properly disposed of.

Table 5-12. Equipment and supplies required for the closure/disestablishment of a patient decontamination site

<i>Equipment and supplies</i>	<i>Per lane</i>	<i>Per lane</i>
	<i>Minimal</i>	<i>Roller System</i>
Large trash bags for contaminated waste.	As needed	As needed
A slurry mixture of hypochlorite or a 5 percent chlorine solution (in buckets).	As needed	
Pails/buckets for hypochlorite slurry or chlorine solution.	2 to 4	2 to 4
Pails/buckets for rinse water.	2 to 4	
Sponges or rags.	2 or more as needed	
Butyl rubber toxicological agent protective aprons.	As needed	
Entrenching tools.	2 to 4	

ADDITIONAL PROFICIENCY SKILLS FOR MEDICAL PLATOON PERSONNEL

5-284. Medical platoon personnel protect themselves, patients, and medical facilities against exposure to CBRN agents (CBRN defense) and, according to the latest developments in science and technology, carry out the measures necessary to maintain and restore the health of personnel exposed to CBRN environments (CBRN medical defense). Table 5-13 (page 5-72 through page 5-73) identifies additional proficiency

skills that are required for medical platoon personnel. These are in addition to the skills outlined in previous paragraphs that apply according to their rank and function.

Table 5-13. Additional proficiency skills for medical platoon personnel

<i>Additional CBRN skills for medical platoon personnel</i>
Effectively protect casualties in a CBRN scenario during first aid, triage, resuscitative and emergency treatment, evacuation, and hospital treatment.
Consider actions that provide an optimum level of protection against CBRN hazards for medical materials, vehicles, and facilities.
Be familiar with fielded collective protection systems for facilities and vehicles, if appropriate.
Possess good knowledge of the acute symptoms of CBRN injuries and their specific countermeasures and potential side effects.
Possess good knowledge of decontamination procedures for CBRN-contaminated patients.
<i>Additional skills for trained medical officers and noncommissioned officers</i>
Have specialized knowledge in contamination control procedures for CBRN-contaminated patients and associated equipment (including RADIAC monitors and chemical-agent monitors). (Applicable to selected medical platoon personnel.)
Have task-oriented, specialized knowledge of the diagnosis and treatment of CBRN injuries and the detection and identification of chemical and biological agents and radiation. (Applicable to medical platoon personnel assigned to perform special CBRN medical defense tasks during missions [anesthesiologists, surgeons, internists, microbiologists, food protection personnel, and veterinarians]).
Be able to convert scientific expert reports into clear advice to the commander. (Applicable to staff and command surgeons.)
Have knowledge of the acute and long-term health effects of CBRN hazards in the deployment area and of the follow-on medical support requirements from those hazards. (Applicable to selected medical platoon personnel with advanced training.)
Have knowledge of the risk benefit balance from wearing individual protective equipment and using prophylactic medical CBRN countermeasures. (Applicable to selected medical platoon personnel with advanced training.)
<i>Additional courses available</i>
Medical Management of Chemical and Biological Casualties (MCBC) course 6H-F26 located on the Army training requirements and resources system website
Field Management of Chemical and Biological Casualties (FCBC) course number: 6H-F37/300-F31 located on the Army training requirements and resources system website
Medical Management of Biological Casualties (MMBC) Online (29 hours) course DHA-US071 located on the Army training requirements and resources system website
Emergency Preparedness Response Course: CBRNE Operator Short Course J3OP-US260 located on the military health system website.
Emergency Preparedness Response Course: CBRN for Medical platoon Personnel and First Responders DMRTI-US018 located on the military health system website.
Emergency Preparedness Response Course: CBRNE Clinician Short Course DMRTI-US017 located on the military health system website.

Table 5-13. Additional proficiency skills for medical platoon personnel (continued)

<i>Action before, during, and after an operation</i>
Establish an inventory of CBRN hazards and infectious endemic diseases in the deployment area, and establish the resulting medical support requirements in relation to countermeasures.
Document and register the position of personnel during possible exposures and the level of protection from that exposure.
Coordinate investigations of unusual sickness and fatalities in situations involving CBRN hazards and endemic diseases.
Conduct outbreak management in the case of highly contagious diseases in a biological scenario.
Conduct post conflict surveillance for illnesses and follow up exposed or potentially exposed forces.
Legend: CBRN chemical, biological, radiological and nuclear CBRNE chemical, biological, radiological, nuclear, and high-yield explosives DMRTI Defense Medical Readiness Training Institute RADIAC radioactivity detection indication and computation

SECTION VII – UNMASKING PROCEDURES

5-285. Medical platoon personnel should unmask as soon as possible except when expecting a live biological or toxin attack. After notifying the next higher headquarters, use the procedures outlined in the following paragraphs to determine if unmasking is safe.

UNMASKING WITH A CHEMICAL DETECTOR KIT

5-286. If a chemical detector kit is available, use it to supplement unmasking procedures. Chemical detectors do not detect all agents; therefore, follow proper unmasking procedures, which take approximately 15 minutes. Once the results are negative, use the following procedures:

- The senior person selects one or two Soldiers to start the unmasking procedures. If possible, they move to a shady place; bright, direct sunlight can cause pupils in the eyes to constrict, giving a false symptom.
- Selected Soldiers unmask for five minutes, then don, seal, and clear their masks.
- Observe the Soldiers for 10 minutes. If no symptoms appear, request permission from higher headquarters to signal ALL CLEAR.
- Watch all Soldiers for possible delayed symptoms. Always have first-aid treatment immediately available in case it is needed.

UNMASKING WITHOUT A CHEMICAL DETECTOR KIT

5-287. If a chemical detector kit is not available, this unmasking procedure takes approximately 35 minutes. Conduct unmasking using these procedures:

- The senior person should select one or two individuals to start the unmasking procedures.
- If possible, move to a shady place (bright, direct sunlight can cause pupils in the eyes to constrict, giving false signs of nerve agent exposure).
- Selected individuals unmask, take a deep breath, hold it, and break the seal for 15 seconds, keeping their eyes wide open.
- Selected individuals clear and reseal their masks.
- Selected individuals are observed for 10 minutes.
- If no symptoms appear, the commander or leader has the selected individuals break the seal of their masks, take two or three breaths keeping their eyes wide open, and clear and reseal their masks.
- Selected individuals are observed for 10 minutes (if no symptoms appear, have the selected individuals unmask for five minutes and then remask).
- If no symptoms appear in 10 minutes after remasking, the medical platoon leader and PSG will inform the commander who will then consider issuing a directive for an ALL CLEAR.
- Watch personnel for possible delayed symptoms (always have first aid treatment immediately available in case it is needed).

ALL-CLEAR SIGNAL

5-288. Units pass the all-clear signal by word of mouth through their chain of command. Leaders initiate the signal after testing for contamination proves negative. The commander designates the specific ALL CLEAR signal and includes it in the unit TACSOP or the OPORD. If required, standard sound signals may be used, such as a continuous, sustained blast on a siren, vehicle horn, or similar device. When ALL CLEAR is announced on the radio, the receiving unit must authenticate the transmission before complying.

Appendix A

Analog Reports

Communication is imperative to the success of the medical platoon. To be able to quickly and accurately report, medical platoon personnel require proficiency in communication equipment, procedures, and reports.

Medical platoons use numerous report formats to ensure clear communications between units and echelons to facilitate common reporting formats (see FM 6-99 for more information on reports and message formats).

SECTION I – CONTACT REPORTS

A-1. Soldiers issue a contact report immediately upon contact with a threat or unknown force in the AO. A contact report is an alert, which can be very brief. A contact report takes priority over all other communications traffic and is primarily transmitted by radio. If Soldiers are already in a hide position and have detected the enemy before being detected first (and time permits) this initial report may be digital. State CONTACT, followed by a description of the threat or unknown force (dismounts) and the cardinal direction from the sender (north).

SPOT REPORT

A-2. The spot report (SPOTREP) is used to report intelligence or status regarding events that could have an immediate and significant effect on current and future operations. This is the initial means for reporting troops in contact and event information. Soldiers always send threat information in the clear. A SPOTREP takes priority over all other routine radio traffic. The initial SPOTREP should follow no more than one minute after the contact report (see ATP 3-20.98, and ATP 3-90.5 for more information. To send a SPOTREP, state SPOTREP followed by pertinent information as referenced in table A-1.

Table A-1. Spot report

LINE ALPHA:	Observer or source (omit if it is the calling station, otherwise use call signs or description).
LINE BRAVO:	Activity or characteristic observed. Use the SALUTE format:
SIZE:	The number of sighted personnel, vehicles, or other equipment.
ACTIVITY:	What the threat is doing.

Table A-1. Spot report (continued)

LOCATION:	Grid coordinates. Report the center of mass for identical, closely grouped items; otherwise, report multiple grid coordinates of traces.
UNIT:	Patches, signs, or markings.
TIME:	Time the observed activity occurred.
EQUIPMENT:	Description or identification of all equipment associated with the activity.
LINE CHARLIE:	Actions the reporting Soldier has taken and personal recommendations. Actions usually involve conducting additional reconnaissance to determine the complete threat situation or recommending and executing a specific course of action.
LINE DELTA:	Self-authentication (if required).

SITUATION REPORT

A-3. Subordinate units submit a situation report (also known as SITREP) on the tactical situation and status to their higher headquarters providing commanders and staffs with sufficient information for the receiving mission command facility to act on the report. Submit the situation report daily, after significant events, or when the platoon leader or commander requests it. State SITUATION REPORT followed by pertinent information referenced from table A-2.

Table A-2. Situation report

LINE 1 – DATE AND TIME:	Date and time group (DTG).
LINE 2 – UNIT:	(Unit making report).
LINE 3 – REPORTED UNIT:	(Unit identification code of the reported unit).
LINE 4 – HOME LOCATION:	(Universal transverse mercator [UTM] or six-digit grid coordinate with military grid reference system [MGRS] designator for home location of the reported unit).
LINE 5 – PRESENT LOCATION:	(UTM or six-digit grid coordinate with MGRS designator for the present location of the reported unit).
LINE 6 – ACTIVITY:	(brief description of reported unit's current activity)
LINE 7 – EFFECTIVE:	(Commander's evaluation of the reported unit's combat effectiveness).
LINE 8 – OWN SITUATION DISPOSITION/ STATUS:	(Summary updating changes to or not previously reported major combatant and support force locations, significant mission readiness degradation on units, current deployments, proposed deployments, changes in task force designations, organization or change of operational control procedures, and projected requirements for additional forces).

Table A-2. Situation report (continued)

LINE 9 – SITUATION OVERVIEW:	(Brief overall assessment of the situation to include circumstances or conditions which increase or materially detract from the capability and readiness of forces assigned or under operational control of the command or service).
LINE 10 – OPERATIONS:	(Brief description and results of offensive and defensive operations carried out by major combatant elements during the period of the report; information on allied forces' operations, summary of plans for combat operations during the next 24 hours including objectives and probable enemy reaction; deviations or variations from previously reported intentions or plans).
LINE 11 – INTELLIGENCE/ RECONNAISSANCE:	(Brief overview of the situation, including operations, threat characteristics, capabilities, and threat changes; reference any significant spot intelligence reports or intelligence reports submitted in the previous 24 hours).
LINE 12 – LOGISTICS:	(Significant deficiencies affecting support for planned operations or problem areas beyond the commander's or Service's capability to overcome or alleviate in a timely manner).
LINE 13 – COMMUNICATIONS/ CONNECTIVITY:	(Significant outages, traffic volume, incompatibilities, and quantitative equipment deficiencies; assessment of the mission impact caused by communications outages and degradations).
LINE 14 – PERSONNEL:	(Factors affecting readiness of forces or units; mobilization status; daily battle casualties aggregated by service and impact of all casualties sustained [battle, nonbattle, critical skills, and key personnel upon the commands' mission capability]).
LINE 15 – POL/MIL/DIP EVENTS:	(Events not reported by operations report that could result in United States and local and international public reaction; results or decisions of key allied or other foreign government meetings; civil unrest indications of civil defense measures contemplated or implemented; large-scale military exercises; events emphasizing interests of key segments of the society).
LINE 16 – COMMANDER'S EVALUATION:	(Summary of key points from lines 9 through 15 highlighting areas requiring Joint Chiefs of Staff and national command authority actions or decisions; continuity of operations implementation intentions on execution).
LINE 17 – NARRATIVE:	(Free text for additional information required for report clarification).
LINE 18 – AUTHENTICATION:	(Report authentication).

SECTION II – STATUS REPORTS

A-4. Units routinely send reports to account for friendly equipment, captured enemy materiel, and personnel. These reports are significant because they relay information that has possible value in a concise format.

SENSITIVE ITEMS REPORT

A-5. Units send the sensitive items report (also known as SENSEREP) daily at prescribed times (before and after significant movement, after significant events, and after any consolidation or reorganization). Items covered include machine guns, personal weapons, night vision devices, binoculars, CBRN equipment, communications electronics operating instruction materials, maps and graphics, and special equipment assigned to platoons for particular operations. To send this report, state SENSITIVE ITEMS REPORT followed by pertinent information referred to in table A-3.

Table A-3. Sensitive items report

LINE ALPHA:	Reporting unit (use call sign).
LINE CHARLIE:	Results of sensitive items check. Use the term UP for on-hand or functional items. For missing items, report the line description and serial number and provide an explanation. Use additional lines from the Yellow 1 report.
LINE ECHO:	The number of sighted personnel, vehicles, or other equipment.

SECTION III – SUSTAINMENT REPORTS

A-6. Units use a sustainment reports to convey the status of logistics items and request resupply. They are also used for maintenance and transportation reports. Units should immediately follow a status report with a request report.

LOGISTICS RESUPPLY REQUEST

A-7. The logistics resupply request (also referred to as LOGRESREP) is used to convey to the battalion logistics staff request of supplies and equipment prior to the next scheduled resupply. Use to request support in a tactical emergency or for urgent tactical requirements (see table A-4). See ADP 4-0 and FM 4-0 for more information.

Table A-4. Logistics resupply request

LINE 1 – DATE AND TIME:	Date and time group (DTG).
LINE 2 – UNIT:	(Unit making request).
LINE 3 – CLASS I:	(Number of meals or water required before next scheduled resupply).
LINE 4 – CLASS III:	(Type and amount of petroleum, oils and lubricants required before next resupply).
LINE 5 – CLASS IV:	(Type and amount of construction material required before next resupply).
LINE 6 – CLASS V:	(Type and amount of ammunition required before next resupply).
LINE 7 – MAINTENANCE:	(Number and quantity by line; number of parts and/or equipment required before next resupply).

Table A-4. Logistics resupply request (continued)

LINE 8 – MEDICAL:	(Number and type of medical equipment or medical support required before next resupply).
LINE 9 – OTHER:	(Number and type of supplies not listed above and required before the next resupply).
LINE 10 – RESUPPLY LOCATION:	(Universal transverse mercator or six-digit grid coordinate with military grid reference system for location of resupply requested).
LINE 11 – SUPPLY STAT:	(Status of unit: RED, AMBER, GREEN).
LINE 12 – NARRATIVE:	(Free text for additional information required for report clarification).
LINE 13 – AUTHENTICATION:	(Report authentication).

LOGISTICS SITUATION REPORT

A-8. The logistics situation report (also referred to as LOGSITREP) is used to report logistics problems, required logistic assistance, reallocation, and recommended or intended courses of action (see table A-5). See reference ADP 4-0 and FM 4-0 for more information.

Table A-5. Logistics situation report

LINE 1 – DATE AND TIME:	Date and time group (DTG).
LINE 2 – UNIT:	(Unit making report).
LINE 3 – MAP:	(Universal transverse mercator or six-digit grid coordinate with military grid reference system designator).
LINE 4 – EVALUATION:	(Major units, combat operation type, and days logistically supportable). UNIT: _____ OPERATION: _____ DAYS: _____
LINE 5 – COMMENT:	(Pertinent unit comments).
LINE 6 – FORCE WEAPON SYSTEMS:	(Line item numbers and quantities on hand [OH], authorized [AUTH], and operational [OPER]). LINE: ___ OH: ___ AUTH: ___ OPER) ___ Requirement (REQ): ___
LINE 7 – AMMUNITION:	(Type of ammunition, quantity on hand, authorized, and operational). TYPE: _____ OH: _____ DUE: _____ RDD: _____ REQ: _____
LINE 8 – CRYOGENICS:	(Comments or status of cryogenics).
LINE 9 – PETROLEUM:	(Product type, quantity, and unit of measure on hand; days of supply). PRODUCT: _____ OH: _____ DAYS: _____ REQ: _____

Table A-5. Logistics situation report (continued)

LINE 10 – EQUIPMENT:	(National stock numbers [NSN] and quantities on hand, authorized, and operational). NSN: ___ OH: ___ AUTH: ___ OPER: ___ REQ: ___
LINE 11 – CRITICAL EQUIPMENT:	(Type, quantity non-operational [NONOP], MDLV as of DTG). TYPE: ___ NONOP: ___ MDLV: ___ AS OF: ___ REQ: ___
LINE 12 – REPAIR MATERIEL:	(Type, NSN, and quantity [QTY] of required repair materiel). TYPE: ___ NSN: ___ QTY: ___ REQ: ___
LINE 13 – RATIONS:	(Ration type, number of meals on hand, and days of supply). TYPE: ___ OH: ___ DAYS: ___ REQ: ___
LINE 14 – WATER:	(Water type [potable or nonpotable], gallons available, and days of supply). TYPE: ___ GALLONS: ___ DAYS: ___ REQ: ___
LINE 15 – COMMANDER'S SUMMARY:	(Narrative comments addressing degraded capabilities, shortages, or problems impacting warfighting capability and recommended courses of action).
LINE 16 – NARRATIVE:	(Free text for additional information required for report clarification).
LINE 17 – AUTHENTICATION:	(Report authentication).
Note. Repeat lines 3 through 15 to report multiple missions/mission data. Assign sequential lines to succeeding iterations. For example, first iteration is 3 through 15; second iteration is 3a through 15a; third iteration is 3b through 15b; and so on.	

MAINTENANCE SUPPORT REQUEST

A-9. The maintenance support request (also referred to as MAINTSPTREQ) is used to request maintenance support (see table A-6).

Table A-6. Maintenance support request

LINE 1 – DATE AND TIME:	Date and time group (DTG).
LINE 2 – UNIT:	(Unit making request).
LINE 3 – REQUESTING AGENCY:	(Identifier or designator of the requesting agency).
LINE 4 – LOCATION:	(Universal transverse mercator or six-digit grid coordinate with military grid reference system [MGRS] designator).
LINE 5 – DATE:	(Date maintenance support is required).
LINE 6 – NOMENCLATURE:	(Category, name, and model of equipment requiring maintenance).
LINE 7 – NO. PIECES:	(Number of pieces of equipment requiring maintenance support).
LINE 8 – TYPE:	(Type of maintenance support required).

Table A-6. Maintenance support request (continued)

LINE 9 – EQUIPMENT LOCATION:	(Universal transverse mercator or six-digit grid coordinate with MGRS designator of equipment needing support).
LINE 10 – CONDITION:	(Brief description of equipment condition).
LINE 11 – SPECIAL INSTRUCTIONS:	(Special instruction relevant to perform support [special tools, components needed]).
LINE 12 – COORDINATION:	(Coordination instructions required between supported and supporting units).
LINE 13 – NARRATIVE:	(Free text for additional information required for report clarification)
LINE 14 – AUTHENTICATION:	(Report authentication)
Note. Repeat lines 3 through 12 for each type of equipment requiring maintenance support. Assign sequential lines to succeeding iterations. For example, first iteration is 3 through 12; second iteration is 3a through 12a; third iteration is 3b through 12b; and so on.	

SLANT REPORT

A-10. The slant report (also known as SLANTREP) is used to give the commander accurate and routine information regarding the status of critical personnel and equipment. This is the initial means for reporting troops in contact and event information (see table A-7). For more information, see reference: ATP 3-90.5.

Table A-7. Slant report

LINE 1 – DATE AND TIME:	Date and time group (DTG).
LINE 2 – UNIT:	(Unit making report).
LINE 3 – COMMANDER'S INFORMATION REQUIREMENT:	(Commander's information requirement).
LINE 4 – EQUIPMENT:	(Equipment).
LINE 5 – PERSONNEL:	(Personnel).
LINE 6 – NARRATIVE:	(Free text for additional information required for report clarification).
LINE 7 – AUTHENTICATION:	(Report authentication).

SECTION IV – MEDICAL REPORTS

A-11. Listed below are various medical reports that the medical platoon leadership need to be familiar with.

MEDICAL EVACUATION REQUEST

A-12. Units send a MEDEVAC request to the medical team on the troop or company command net to request MEDEVAC support (see table A-8 on page A-8). Also see ATP 4-02.2, ATP 4-02.55 and GTA 08-01-004 for more information.

Table A-8. Medical evacuation request

LINE 1 – LOCATION:	(Specify the grid coordinates for the six-digit grid location, with military grid reference system designator of pickup site location).	
LINE 2 – RADIO FREQUENCY AND CALL SIGN:	(The frequency and call sign is the radio frequency call sign, and suffix at the pickup site of the unit requesting evacuation).	
LINE 3 – NUMBER OF PATIENTS BY PRECEDENCE:	Classify the casualties' priority for evacuation using the following terms:	
	A. Urgent. Evacuation required within two hours saving life or limb.	
	B. Urgent-Surgical.	
	C. Priority. Patient's medical condition is deteriorating, becoming urgent within four hours.	
	D. Routine. Evacuation required, but several hours until patient's condition expected to deteriorate.	
LINE 4 – SPECIAL EQUIPMENT:	E. Convenience.	
	A. None.	
	B. Hoist.	
LINE 5 – NUMBER AND TYPE OF PATIENTS:	C. Extraction equipment.	
	(Total number of patients by type).	
	A + number of patients – ambulatory.	
LINE 6A – SECURITY OF PICKUP SITE (WARTIME):	L + number of patients – litter.	
	N. No enemy troops in area.	
	P. Possible enemy troops in area (armed escort required).	
	X. Enemy troops in area (armed escort required).	
LINE 6B – NUMBER TYPE OF WOUND, INJURY, OR ILLNESS (PEACETIME):	E. Enemy troops in area (approach with caution).	
	Specific information regarding patient wounds by type).	
LINE 7 – METHOD OF MARKING THE PICKUP ZONE:	A. Panels.	
	B. Pyrotechnic signal.	
	C. Smoke signal.	
	D. None.	
	E. Other.	
LINE 8 – PATIENT NATIONALITY:	A. United States or coalition military.	
	B. United States or coalition civilian.	
	C. Non-United States or coalition military.	
	D. Non-United States or coalition civilian.	

Table A-8. Medical evacuation request (continued)

LINE 9A – CBRN CONTAMINATION (WARTIME):	C. Chemical.	
	B. Biological.	
	R. Radiological.	
	N. Nuclear.	
	U. Unknown.	
	A. All clear.	
LINE 9B – TERRAIN DESCRIPTION (PEACETIME):	(Description of terrain features at the proposed pick-up site).	
LINE 10 – AUTHENTICATION:	(Report authentication).	

MEDICAL LOCATION REPORT

A-13. The medical location report (also known as MEDLOC) is used to report location and relocation of medical units and to assist with the determination of patient handling capabilities, allocation or reallocation of resources, and diversion of evacuation resources during operations (see table A-9). See ATP 4-02.1 for more information.

Table A-9. Medical location report

LINE 1 – DATE AND TIME:	Date and time group (DTG).
LINE 2 – UNIT:	(Unit making report).
LINE 3 – DEPARTURE:	(Estimated DTG departure old location).
LINE 4 – ARRIVAL:	(Estimated DTG arrival new location).
LINE 5 – OPERATIONAL TIME:	(Estimated DTG operational new location).
LINE 6 – AVAILABLE:	(Number of cots or hospital beds available).
LINE 7 – NEW LOCATION:	(Universal transverse mercator or six-digit grid coordinate with military grid reference system designator).
LINE 8 – PATIENTS:	(Number of patients requiring evacuation).
LINE 9 – NARRATIVE:	(Free text for additional information required for report clarification).
LINE 10 – AUTHENTICATION:	(Report authentication).

MEDICAL SITUATION REPORT

A-14. The medical situation report (also known as MEDSITREP) is used to convey a quick, consolidated medical status report as a snapshot instead of a full report (see table A-10 on page A-10).

Table A-10. Medical situation report

LINE 1 – DATE AND TIME:	Date and time group (DTG).
LINE 2 – UNIT:	(Unit making report).
LINE 3 – LOCATION:	(Universal transverse mercator or six-digit grid coordinate with military grid reference system designator).
LINE 4 – STATUS:	(Number of operational cots, unoccupied cots, or number of cots uploaded).
LINE 5 – PATIENTS:	(Number of patients).
LINE 6 – PROJECTED LOCATIONS:	(Anticipated operations in the next 24 hours; anticipated opening and closing times at new locations).
LINE 7 – MEDICAL LOGISTICS:	(Number of days of Class VIII and blood on hand).
LINE 8 – EVACUATION ASSETS:	(Availability and operational capacity of evacuation assets).
LINE 9 – NARRATIVE:	(Free text for additional information required for report clarification).
LINE 10 – AUTHENTICATION:	(Report authentication).

MEDICAL SPOT REPORT

A-15. The medical spot report (also known as MEDSPTREP) is used to report major medical incidents (see table A-11).

Table A-11. Medical spot report

LINE 1 – DATE AND TIME:	Date and time group (DTG).
LINE 2 – UNIT:	(Unit making report).
LINE 3 – INCIDENT:	(DTG of incident).
LINE 3 – LOCATION:	(Universal transverse mercator or six-digit grid coordinate with military grid reference system designator of emergency).
LINE 5 – EMERGENCY:	(Specified medical emergency).
LINE 6 – UNIT AFFECTED:	(Affected friendly unit).
LINE 7 – NARRATIVE:	(Free text for additional information required for report clarification).
LINE 8 – AUTHENTICATION:	(Report authentication).

SECTION V – PERSONNEL REPORTS

A-16. Units use personnel reports to notify the command group of casualties and to request replacement personnel. A request for replacements must immediately follow a casualty report.

PERSONNEL STATUS REPORT

A-17. The personnel status report (also known as PERSTAT) is used to report the status of the unit's personnel (see table A-12). For more information, see reference FM 1-0.

Table A-12. Personnel status report

LINE 1 – DATE AND TIME:	Date and time group (DTG).
LINE 2 – UNIT:	(Unit making report).
LINE 3 – FROM:	(DTG for the beginning of period applying to personnel information).
LINE 4 – TO:	(DTG for the end of report period).
LINE 5 – UNIT:	(Designation of the unit for which the personnel status information is submitted).
LINE 6 – AUTHORIZED:	(Number of personnel authorized by personnel classification).
LINE 7 – ASSIGNED:	(Number of personnel assigned by personnel classification).
LINE 8 – On Hand (OH):	(Number of personnel on hand by personnel classification).
LINE 9 – GAINS:	(Number of personnel gains by personnel classification).
LINE 10 – REPLACEMENTS:	(Number of personnel gained that are replacements by personnel classification).
LINE 11 – RETURNED TO DUTY:	(Number of personnel gained duty through medical channels by personnel classification).
LINE 12 – KILLED:	(Number of personnel killed in action by personnel classification).
LINE 13 – WOUNDED:	(Number of personnel wounded in action by personnel classification).
LINE 14 – NONBATTLE LOSS:	(Number of disease and nonbattle injury losses by personnel classification).
LINE 15 – MISSING:	(Number of missing in action by personnel classification).
LINE 16 – DESERTERS:	(Number of deserters by personnel classification).
LINE 17 – AWOL:	(Number absent without leave by personnel classification).
LINE 18 – CAPTURED:	(Number of enemy personnel).
LINE 19 – NARRATIVE:	(Free text for additional information required for report clarification).
LINE 20 – AUTHENTICATION:	(Report authentication).
Note. Repeat lines 5 through 18 to report the personnel summary of additional units. Assign sequential lines to succeeding iterations. For example, first iteration is 5 through 18; second iteration is 5a through 18a; third iteration is 5b through 18b; and so on.	

SECTION VI – CHEMICAL, BIOLOGICAL, RADIOLOGICAL, NUCLEAR, EXPLOSIVE REPORTS

A-18. Units use CBRN explosives reports to describe contaminated areas, means of delivery, persistence, and initial agent identification. Units ensure that appropriate protective postures occur before gathering information for CBRN reports. Medical platoons should utilize GTA 03-06-008 as a tool for CBRN warning and reporting.

CBRN-1—OBSERVER’S INITIAL REPORT

A-19. The CBRN 1 report may use CHEM/BIO/RAD/NUC to represent a chemical report, biological report, radiological report, or nuclear report respectively. To send the CBRN-1 report, state CBRN ONE and give the type of CBRN incident. Other information that may be sent includes precedence of the report, date and time of the report (universal time [also called ZULU]), and security classification with the FROM and TO times the classification is applicable. The report format is CBRN ONE, followed by all pertinent information as shown in table A-13.

Table A-13. Chemical, biological, radiological, and nuclear-1—Observer’s initial report

Line ALPHA:	Strike serial number (if known).
Line BRAVO:	Position of observer (Universal transverse mercator [UTM] coordinates or name of place).
Line DELTA:	Date and time group (DTG) attack started, ZULU.
Line FOXTROT:	Location of attack (UTM coordinates) and vicinity of attack (actual or estimated, specify which is given).
Line GOLF:	Means of delivery and quantity (if known).
Line HOTEL:	(For CBRN 1 nuclear reports) Type of burst (air, surface, unknown), type of toxic agent, or type of attack.
Line INDIA:	Release information (number of shells, other data) not mandatory for radiological or nuclear.
Line INDIAR:	(For CBRN-1 radiological reports) release and sampling information on radiological incidents.
Line JULIET:	Flash-to-bang time (in seconds).
Line KILO:	Crater present or absent, diameter in meters (if known).
Line LIMA:	Cloud width (degrees or milliradians, specify which) five minutes after burst.
Line MIKE:	Description and status of chemical, biological, and radiological incidents. Cloud height (top or bottom, specify which) ten minutes after burst (degrees or mils, specify which).
Line SIERRA:	DTG of reading or initial detection of contamination (local or ZULU time).
Note. DO NOT DELAY REPORTS in an attempt to provide a complete CBRN-1 report. Omit information that is not applicable or available. Items always reported are the type of report; lines D and H; and one of the following lines: B, C, F, or G. Carefully specify the units of measure used (such as degrees, milliradians, or grid azimuth).	

CBRN-3—IMMEDIATE WARNING OF EXPECTED CONTAMINATION

A-20. The CBRN-3 report is by radio. The CBRN 3 report will be prepared by the CBRN cell and transmitted to provide warning to units in or near the expected area of contamination. The CBRN-3 report will contain the location of attack and grid coordinates for plotting the area of expected hazard area. The report format is CBRN THREE, followed by pertinent information located on table A-14.

Table A-14. Chemical, biological, radiological, and nuclear-3—Immediate warning of expected contamination

Line ALPHA:	Strike serial number (if known).
Line DELTA:	Date and time group (DTG) when attack started.
Line FOXTROT:	Location of attack (actual or estimated, specify which).
Line PAPA:	Area of expected contamination.
Line YANKEE:	Bearing or azimuth of left, then right radial lines (specify degrees or mils, use four digits for each line).
Line ZULU:	Effective downwind speed (in kilometers per mile, use three digits), downwind effective distance of zone (in kilometers, use three digits), and cloud radius (in kilometers, use two digits).

CBRN-5—REPORT OF AREAS OF CONTAMINATION

A-21. The CBRN 5 report will be prepared by the CBRN cell or controlling headquarters and transmitted to distribute information about the contaminated area consolidated from CBRN 4 reports. Units may send other information including precedence of the report, date and time of the report (ZULU), and security classification with from and to for the length of time the classification is applicable. The report format is CBRN FIVE, followed by all pertinent information depicted in table A-15.

Table A-15. Chemical, biological, radiological, and nuclear -5—Report of areas of contamination

Line ALPHA:	Strike serial number, if known.
Line OSCAR:	Reference date and time group (DTG) for estimated contours of contaminated areas.
Line SIERRA:	DTG when detection of contamination occurred.
Line TANGO:	H+1 DTG or DTG of latest reconnaissance of contamination in the area.
Line UNIFORM:	Coordinates of contour lines marking dose rate of 1000 cGy/hr.
Line VICTOR:	Coordinates of contour lines marking dose rate of 300 cGy/hr.
Line WHISKEY:	Coordinates of contour lines marking dose rate of 100 cGy/hr.
Line X-RAY:	Coordinates of contour lines marking dose rate of 20 cGy/hr.

DECONTAMINATION REQUEST

A-22. The decontamination request (also referred to as DECONREQ) will be prepared by the contaminated unit to request a unit (see ATP 3-11.32) or patient decontamination (see ATP 4-02.7/MCRP 3-40A.6/NTTP 4-02.7/AFTTP 3-42.3). Provide all pertinent information as depicted in table A-16.

Table A-16. Decontamination request

LINE 1 – DATE AND TIME:	(Date and time group (DTG).
LINE 2 – UNIT:	(Unit making request).
LINE 3 – TYPE DECONTAMINATION:	(Type of decontamination support required: operational, thorough or patient).
LINE 4 – TIME AND LOCATION:	(Time of contamination and location).
LINE 5 – TYPE AND QUANTITY:	(Type and quantity of equipment to be decontaminated).
LINE 6 – DECONTAMINATION LOCATION:	(Universal transverse mercator or six-digit grid coordinate with military grid reference system designator of decontamination site location).
LINE 7 – PERSONNEL:	(Number of personnel requiring decontamination).
LINE 8 – TYPE CONTAMINATION:	(Type of contamination: nuclear, biological, or chemical [if chemical, type of agent if known]).
LINE 9 – TIME TO DECONTAMINATION:	(Request time to start decontamination).
LINE 10 – LINK-UP POINT OF CONTACT:	Frequency and call sign of link-up point and point of contact).
LINE 11 – COMMAND POST AT DECONTAMINATION SITE:	(Link-up point for decontamination assets).
LINE 12 – SPECIAL REQUIREMENTS:	(Patient decontamination, recovery assets, unit decontamination team).
LINE 13 – NARRATIVE:	(Free text for additional information required for report clarification).
LINE 14 – AUTHENTICATION:	(Report authentication).
Note. **Repeat lines 3 through 12 to report multiple missions/mission data. Assign sequential lines to succeeding iterations. For example, first iteration is 3 through 12; second iteration is 3a through 12a; third iteration is 3b through 12b; and so on.	

Appendix B

Medical Battle Drills

Maneuver battalion medical platoons and treatment squads undergo extensive training to conduct Army Health System support in all operational environments. In preparation for these operations, battle drills are used to train and establish procedures to perform their mission. Battle drills are standardized collective actions made in response to common battle occurrences. They are designed for rapid reaction situations without the application of a deliberate decision-making process.

SELECTED MEDICAL BATTLE DRILLS

B-1. Battle Drills are initiated on a cue, such as an enemy action or the leader's order and are a trained response to that stimulus. They require minimal leader orders to accomplish and are vital to success in combat and critical to preserving life.

B-2. This appendix identifies essential battle drills that a medical platoon and treatment squad must train on to ensure success. They include:

- Battle Drill 1: Establish the Battalion Aid Station.
- Battle Drill 2: React to a Mass Casualty.
- Battle Drill 3: Establish a Casualty Collection Point.
- Battle Drill 4: Establish a Patient Decontamination Site.

SECTION I – BATTLE DRILL 1: ESTABLISH THE BATTALION AID STATION

B-3. The field surgeon and/or PA, with input from the treatment SQDLDR selects a site for the aid station that allows access to MEDEVAC landing site and ground ambulances while maintaining security. The provider and SQDLDR ensure that the aid station is established to provide Role 1 medical care. The care is continuous from the POI through the BAS and on to higher roles of care as required. All care is conducted according to unit TACSOP and the guidance from the field surgeon and PA.

B-4. Detailed in table B-1 (see pages B-2 through B-3) are the steps and measures utilized to establish the BAS. More information on each step can be found in chapter 1.

Table B-1. Establish the battalion aid station

<i>STEP/MEASURE</i>	<i>GO</i>	<i>NO-GO</i>	<i>N/A</i>
<p>+* 1. Treatment squad leader selects and coordinates a site for the BAS within the designated area according to the commander's guidance/tactical standard operation procedure (TACSOP).</p> <ul style="list-style-type: none"> a. Selects an area that provides the best cover, concealment, drainage, and access to and egress from evacuation vehicles and helicopter landing site. b. Obtains approval to occupy selected site from Command Post. c. Notifies supporting medical facility and all supported units of movement of aid station, location of new site, and estimated time to be operational. d. Examines entire selected site for placement of all medical treatment team assets and selects areas for all assets that do not impede access to and egress from the aid station or patient flow. 			
<p>+ 2. The medical treatment team members establish the aid station according to the field surgeon/physician assistant's guidance and the TACSOP.</p> <ul style="list-style-type: none"> a. Begins tailgate medical support and positions all supplies and medical equipment sets so as not to impede patient flow. b. Protects all supplies and equipment from the weather. c. Erects all tentage according to the TACSOP. d. Camouflages and/or conceal the entire area per TACSOP (if tactical situation permits). e. Provides combat medic assistance until the battalion aid station (BAS) is operational. 			
<p>+ 3. The medical treatment team establishes a medical section with augmented brigade support medical company (BSMC) ambulances if needed/applicable.</p> <ul style="list-style-type: none"> a. Uses only essential supplies and equipment. b. Uses all available cover and concealment. c. Maintains communications (radios, wire, voice, and, visual) with higher headquarters or Role 2 augmentation. 			
<p>+ 4. The section establishes an ambulance turnaround point. Selects site that provides access to evacuation routes and parking area allowing for maximum cover and/or concealment.</p>			
<p>+* 5. The TACSOP maintains all supply levels (Class VIII and nonmedical) and equipment according to the commander's guidance, TACSOP, and logistic resupply requirements.</p>			

Table B-1. Establish the battalion aid station (continued)

STEP/MEASURE	GO	NO-GO	N/A
+* 6. The treatment squad leader prepares and submits all required reports according to the TACSOP and Annex R (Reports).			
+* 7. The field surgeon receives, stores, processes, transmits, and reports medical surveillance, casualty movement/tracking, medical treatment, medical situational awareness, and medical data through the Defense Health Information Management System.			
+* 8. The field surgeon and/or physician assistant develop and rehearse a mass casualty and triage plan for the unit in accordance with unit TACSOP.			
+* 9. Commander and field surgeon/physician assistant identify and brief the route to next higher level care facilities. Provides maps and route sketches as required.			
Legend: + indicate critical steps * indicate leader steps; plus signs			

SECTION II – BATTLE DRILL 2: REACT TO A MASS CASUALTY

B-5. *Mass casualty* is any large number of casualties produced in a relatively short period of time, usually as the result of a single incident such as a military aircraft accident, hurricane, flood, earthquake, or armed attack that exceeds local logistic support capabilities. Also called MASCAL (JP 4-02).

B-6. Mass casualty incidents occur when the number of casualties exceeds the available medical capability to rapidly treat and evacuate them. Therefore, the actual number of casualties varies before a MASCAL situation is declared depending upon the availability of the medical platoon resources. Technically, a MASCAL occurs if a combat medic has more than one seriously injured Soldier to be cared for at one time. A MASCAL situation could occur from incidence such as an ambush of a platoon where 18 Soldiers are wounded, an accident involving a troop carrier where 30 Soldiers are hurt, or the use of CBRN weapons where hundreds of Soldiers are injured. However, if the same patient presented to the medical treatment squad at the BAS, the patient could be treated by one of two providers and six enlisted medics. By having the medical resources of the medical treatment squad available, the impact of the MASCAL situation is effectively reduced.

B-7. Detailed in table B-2 on pages B-4 through B-7 are the steps and measures utilized to react to a MASCAL. More information on each step can be found in chapter 1.

Table B-2. React to a mass casualty incident

<i>STEP/MEASURE</i>	<i>GO</i>	<i>NO-GO</i>	<i>N/A</i>
+*1. In order to save time and prevent confusion, the medical platoon must have detailed standard operation procedures on mass casualty (MASCAL) incidents to provide purposeful and timely direction. Confusion is limited because MASCAL is a battalion focus and must be planned, trained on, and is rehearsed per operation order.			
+*2. Reacting to a MASCAL must be rehearsed. By conducting rehearsals. Unit personnel become familiar with where they should report and their roles and responsibilities. This rehearsal includes the battalion staff and is included in the sustainment rehearsal.			
3. Nonmedical personnel assigned to the battalion should be trained in the proper techniques for loading, carrying, and unloading litters. Also known as aid and litter teams.			
4. Receive the notification from higher headquarters that a MASCAL incident has just occurred inside the unit area of operation, ensure the medical platoon receives critical information such as: exact location, time, type of casualty producing weapon, and frequencies or communication.			
5. The senior service member on scene immediately establish security, set up a command post, assesses their assets, and sends a situation report to higher headquarters.			
6. Ensure there is a dismount point for which patients can arrive.			
+*7. Establish a triage location and/or casualty collection point (CCP). See table B-3 for how to establish a CCP.			
+*8. Utilize the sort, assess, lifesaving interventions (tactical field care), and transport (SALT) triage algorithm.			
a. SORT: Initially sort the patients by three visual methods, walk, wave, or still: (1) If they are still or have obvious life threats, assess first. (2) Of If they can wave or have purposeful movement, assess second. (3) If they are walking, assess third.			
b. ASSESS: Utilize the delayed, immediate, minimal, and expectant (DIME) triage categories to refine the sorting of patients: (1) DELAYED (YELLOW): Patients in the delayed category can tolerate evacuation delay from 8-10 hours without unduly compromising the likelihood of a successful outcome. When medical resources are overwhelmed, Soldiers in this category are held until the IMMEDIATE cases are cared for.			

Table B-2. React to a mass casualty incident (continued)

STEP/MEASURE	GO	NO-GO	N/A
<p>(2) IMMEDIATE (RED): This category is for the patient whose condition demands immediate, resuscitative treatment and evacuation within 2-4 hours. Generally, the procedures used are short in duration and economical in terms of medical resources.</p> <p>(3) MINIMAL (GREEN): This category consists of patients with superficial wounds who can be returned to duty or evacuation can be delayed up to 24 hours.</p> <p>(4) EXPECTANT (BLACK): Patients in the expectant category have wounds that are so extensive their survival would be very unlikely would be very unlikely and utilize and unjustifiable expenditure of limited resources. The EXPECTANT patients should be separated from the view of others; however, they should not be abandoned. Above all, attempts to make them comfortable should be made by whatever means necessary and to provide attendance by a minimal but competent staff.</p>			
<p>c. TACTICAL FIELD CARE: During the tactical field care (TFC) phase, medical platoon personnel and their patients are no longer under effective hostile fire, and medical personnel can provide more extensive patient care. In this phase, interventions directed at other life-threatening conditions, as well as resuscitation and other measures to increase the comfort of the patient, may be performed by combat medics with combat lifesavers' (CLS) assistance. During TFC, personnel must be prepared to transition back to care under fire or to prepare the patient for tactical evacuation, as the tactical situation dictates.</p>			
<p>d. TRANSPORT (TACTICAL EVACUATION): In the tactical evacuation phase, patients are transported from the CCP to the battalion aid station (BAS). The MASCAL plan should include provisions for the use of nonmedical vehicles and aircraft (casualty evacuation [CASEVAC]). When at all possible, patients who have sustained more severe wounds should be evacuated in medical ground and air ambulances (medical evacuation [MEDEVAC]). The lightly wounded and stable patients and those suffering from behavioral health injuries can be transported by CASEVAC platforms without effecting their medical prognosis:</p> <p>(1) Brigade support medical company (BSMC) augmentee ambulance crews will transport patients to the designated landing zone (LZ) should they need air evacuation to a Role 2 or 3 medical unit.</p>			

Table B-2. React to a mass casualty incident (continued)

STEP/MEASURE	GO	NO-GO	N/A
<ul style="list-style-type: none"> (2) Battalion aid station will be in constant communication with higher medical assets, to include the brigade surgeon. (3) Receiving facility will require the 9-Line MEDEVAC request to be accurate for patient evacuation. Combining patients on the 9-line message is encouraged. (4) Proper triage identification and medical care of patients will continue throughout the continuum of medical care. (5) If a patient needs to be ground evacuated to a Role 2 or 3 medical unit, BAS communications/ambulance crew will coordinate efforts with battalion staff to identify means of transportation. (6) Ambulance team leader will manage all ground and aerial medical evacuations. (7) When established by the officer in charge that all patients have been positively identified, receiving treatment, considered stable, or evacuated to a Role 2 or 3 medical unit, the BAS will be medically cleared and incident debrief will be held by MASCAL Officer at the BAS. 			
<p>9. Battalion Aid Station Response:</p> <ul style="list-style-type: none"> (1) Patients will be properly triaged and directed to the proper treatment area per tactical standard operating procedures (TACSOP)/provider's guidance. (2) Administrative personnel number patients per TACSOP and track each in the MASCAL log book with the patient's injury. After all patients have triaged at the BAS, an admin staff member will record the name, Department of Defense identification or social security number, date of birth, and unit with each corresponding number. In addition, they will maintain last recorded disposition of any patient transported to alternate sites. (3) Providers/treatment personnel will ensure all patients receive immediate and professional Role 2 medical care. All patients will continue to receive treatment based on an ongoing triage. (4) Supply noncommissioned officers will ensure that the BAS remains adequately stocked throughout the evolution. All medical equipment and supplies required for an incident will be properly stored and maintained. Prepackaged and prepositioned triage and first aid supplies will be utilized should the incident require. 			

Table B-2. React to a mass casualty incident (continued)

STEP/MEASURE	GO	NO-GO	N/A
(5) Commanders will designate personnel to ensure the flow of patient traffic is not obstructed. They will detain any person who appears to be a threat to themselves or others.			
(6) Commander will designate personnel to supervise the temporary morgue per unit TACSOP. They should ensure the comfort of all expectant patients and maintain records of all personal items of the deceased.			
10. Medical platoon personnel will use a patient accountability tracker according to unit medical TACSOP. The DD Form 1380 is used to record the treatment and medications the patient receives and is attached to the individual's clothing. When the MASCAL incident begins to resolve, and as time permits, medical platoon personnel obtain the necessary information to complete the DD Form 1380.			
11. In a MASCAL incident, there will be casualties who have died before reaching the triage area dead on arrival or who die of wounds before they can be stabilized and further evacuated. A temporary morgue area should be established according to the TACSOP away from and out of sight of the triage and treatment areas. A DD Form 1380 must be completed on each of the deceased personnel, and it must be signed by a physician. The human remains cannot be evacuated by the medical platoon. They are held and/or marked by an 8-digit grid coordinate until mortuary affairs support can be obtained.			
12. The medical platoon maintains a list of names of those evacuated in the form of a log-in and log-out format and submits to the personnel staff as a report according to the unit TACSOP.			
Legend: + indicate critical steps * indicate leader steps; plus signs			

SECTION III – BATTLE DRILL 3: ESTABLISH A CASUALTY COLLECTION POINT

B-8. The CCP is a location that may or may not be staffed, where casualties are assembled for evacuation to a Role 1 BAS. Casualty collection point are normally predesignated along the axis of advance or evacuation routes. Forward of the BAS, the combat medic, CLS, and combat troops take casualties to the CCPs. These points facilitate acquisition of casualties by supporting ambulance teams and reduce evacuation time. When used by the BAS, CCPs help preserve BAS mobility, preclude carrying casualties forward, and reduce evacuation time to the sustainment area.

B-9. Detailed in table B-3 are the steps and measures utilized to establish the CCP. More information on each step can be found in chapter 1.

Table B-3. Establish a casualty collection point

<i>STEP/MEASURE</i>	<i>GO</i>	<i>NO-GO</i>	<i>N/A</i>
+*1. In order to save time and prevent confusion, the medical platoon must have detailed standard operation procedures for establishing a casualty collection point (CCP) to provide purposeful and timely direction. Confusion is limited because the CCP is a company focus and must be planned, trained on, and is rehearsed per operation order.			
+*2. Establishing a CCP must be rehearsed. With rehearsals unit personnel become familiar with where they should report and their roles and responsibilities. The casualty response rehearsal includes the battalion staff and is included in the sustainment rehearsal.			
3. Nonmedical personnel assigned to the battalion should be trained in the proper techniques for loading, carrying, and unloading litters. Also known as aid and litter teams.			
4. Casualty Collection Point Site Selection. Selecting a site for the CCP should be addressed during the planning phase of military decision-making process (MDMP); however, mission, enemy, terrain, troops, time available, and civilian considerations (METT-TC) will become a factor as operations commence. Listed below are some factors to consider a tactical location for a CCP: <ul style="list-style-type: none"> a. Reasonably close to the fight. b. Near templated areas of expected high casualties. c. Cover and concealment. d. In building or on hardstand (exclusive CCP building limits confusion). e. Access to evacuation routes and assets (foot, vehicle, and aircraft). f. Proximal to paths across terrain that are the most likely to be used when going from one place to another. g. Adjacent to objective choke points (breaches, helicopter landing zone [HLZ]) (see figure C-1 on page C-7). h. Avoid natural or enemy choke points. i. Area allowing passive security (inside the perimeter). j. Good drainage. k. Trafficable for use by evacuation assets. l. Expandable if casualty load increases. 			

Table B-3. Establish a casualty collection point (continued)

STEP/MEASURE	GO	NO-GO	N/A
<p>+ 5. The supported unit is responsible for everything OUTSIDE the CCP. They maintain control of the CCP by conducting the following:</p> <ul style="list-style-type: none"> a. Maintains ingress and egress to the CCP. b. Maintains control lines using engineer tape or other obstacles to ensure casualties are properly routed to the CCP. c. Control of casualties at the CCP. d. Ensures casualties do not bypass the CCP. e. Separates ambulatory and non-ambulatory casualties. f. Assists casualties to the triage station. g. Establish the CCP with day and night marking systems according to the tactical standard operating procedures (TACSOP). h. Maintains command and control (C2) and battlefield situational awareness. i. Identifies and controls aid and litter teams and provides security. j. Maintains casualty sensitive items equipment outside of treatment area according to the TACSOP. k. Accountable for tracking casualties and equipment in and out of CCP and provides reports to higher. l. Move casualties through CCP entrance / exit choke point marked according to the TACSOP. 			
<p>+6. Medical personal are responsible for everything INSIDE the CCP.</p> <ul style="list-style-type: none"> a. Establish a triage area with day and night marking systems. b. Establish an exit point from the CCP to track patients. c. Establish and properly mark evacuation categories for day and night (non-tactical or tactical) operations. <p>Note. Marking procedures will be outlined in the unit's TACSOP.</p>			
<p>+*7. Utilize the sort, assess, lifesaving interventions (tactical field care), and transport (SALT) triage algorithm.</p>			

Table B-3. Establish a casualty collection point (continued)

STEP/MEASURE	GO	NO-GO	N/A
<p>a. SORT: Initially sort the patients by three visual methods, walk, wave, or still.</p> <p>(1) If they are still or have obvious life threats, assess first.</p> <p>(2) If they can wave or have purposeful movement, assess second.</p> <p>(3) If they are walking, assess third.</p>			
<p>b. ASSESS: Utilize the delayed, immediate, minimal, and expectant (DIME) triage categories to refine the sorting of patients:</p> <p>(1) DELAYED (YELLOW): Patients in the delayed category can tolerate evacuation delay from 8-10 hours without unduly compromising the likelihood of a successful outcome. When medical resources are overwhelmed, Soldiers in this category are held until the IMMEDIATE cases are cared for.</p> <p>(2) IMMEDIATE (RED): This category is for the patient whose condition demands immediate, resuscitative treatment and evacuation within 2-4 hours. Generally, the procedures used are short in duration and economical in terms of medical resources.</p> <p>(3) MINIMAL (GREEN): This category consists of patients with superficial wounds who can be returned to duty or evacuation can be delayed up to 24 hours.</p> <p>(4) EXPECTANT (BLACK): Patients in the expectant category have wounds that are so extensive their survival would be very unlikely would be very unlikely and utilize and unjustifiable expenditure of limited resources. The EXPECTANT patients should be separated from the view of others; however, they should not be abandoned. Above all, attempts to make them comfortable should be made by whatever means necessary and to provide attendance by a minimal but competent staff.</p>			

Table B-3. Establish a casualty collection point (continued)

STEP/MEASURE	GO	NO-GO	N/A
<p>c. TACTICAL FIELD CARE: During the tactical field care (TFC) phase, medical platoon personnel and their patients are no longer under effective hostile fire, and medical platoon personnel can provide more extensive patient care. In this phase, interventions directed at other life-threatening conditions, as well as resuscitation and other measures to increase the comfort of the patient, may be performed by combat medics with combat lifesavers' (CLS) assistance. During TFC, personnel must be prepared to transition back to care under fire or to prepare the patient for tactical evacuation, as the tactical situation dictates.</p>			
<p>d. TRANSPORT: Plan movement of patients (Tactical Evacuation): In the tactical evacuation phase, patients are transported from the CCP to the battalion aid station (BAS).</p> <ol style="list-style-type: none"> (1) Casualty movement from point of injury (POI) to the platoon CCP will be by field expedient means: walking, manual carries, litter carries, or casualty evacuation (CASEVAC) vehicle. (2) Nonstandard CASEVAC vehicles are positioned forward with a track or wheeled ambulance designated for litter casualties at the company CCP. (3) The first sergeant coordinates casualty flow between the platoon CCPs and the company CCP while the senior medic conducts triage. (4) Communication of 9-line medical evacuation requests is conducted via the platoon or company elements to the battalion aid station (BAS.) (5) The procedure/drill from the CCP to the BAS focuses largely on distance, routes, security, and TACSOP at the BAS. 			
<p>8. Establish a centralized medical resupply area where supplies can be stored according to the TACSOP.</p>			
<p>9. Establish and mark an HLZ per FM 3-21.38. See appendix C, figure C-1 and table C-5 on page C-7 of this publication.</p>			
<p>10. Medical platoon personnel will use a patient accountability tracker according to unit medical TACSOP. The DD Form 1380 is attached to the individual's clothing. The DD Form 1380 is used to record the treatment and medications that the patient receives. When the CCP begins to resolve, and as time permits, medical platoon personnel obtain the necessary information to complete the DD Form 1380.</p>			

Table B-3. Establish a casualty collection point (continued)

STEP/MEASURE	GO	NO-GO	N/A
11. While conducting CCP operations, there will be patients who have died of wounds after reaching the triage area before they can be stabilized and further evacuated. A temporary morgue area should be established according to the TACSOP away from and out of sight of the triage and treatment areas. A DD Form 1380 must be completed on each of the deceased personnel, and it must be signed by a physician. The human remains cannot be evacuated by the medical platoon. They are held and/or marked by an 8-digit grid coordinate until mortuary affairs support can be obtained.			
12. The medical platoon maintains a list of names of those evacuated in the form of a log-in and log-out format if no form is already established and submits to the personnel staff as a report according to the unit TACSOP.			
Legend: + indicate critical steps * indicate leader steps; plus signs.			

SECTION IV – BATTLE DRILL 4: ESTABLISH A PATIENT DECONTAMINATION SITE

B-10. The medical platoon must be able to set up a fully operational PDS in a non-contaminated area upwind from the chemical hazard. Establish the decontamination area on the downwind side of the protective shelter or other clean treatment area and clearly mark a hot line. Construct a shuffle pit as the only point of access to the clean areas. Install chemical agent alarms.

B-11. The steps and measures utilized to establish the PDS are detailed in table B-4. More information on each step can be found in ATP 4-02.7/MCRP 3-40A.6/NTTP 4-02.7/AFTTP 3-42.3, chapter 5.

Table B-4. Establish a patient decontaminate site

STEP/MEASURE	GO	NO-GO	N/A
+*1. There is no wrong or right way to react to a chemical, biological, radiological, and nuclear (CBRN) mass casualty (MASCAL) incident. What the medical platoon has against it is time and confusion. The medical platoon must have detailed standard operations procedures (SOPs) on MASCAL incidents so that time is not wasted figuring out what to do. Confusion is limited because MASCAL is a battalion focus, it must be planned, trained on, and is rehearsed per operation order (OPORD).			
+*2. To ensure a proper response to a CBRN MASCAL it must be rehearsed. By conducting rehearsals, unit personnel become familiar with where they should report and with what their duties should entail. The Casualty Response Rehearsal also includes the battalion staff. Ensure these rehearsals are included in the overall sustainment rehearsal per TACSOP. Note. Nonmedical personnel assigned to the battalion should be trained in the proper techniques for washing contaminated patients to include loading, carrying, and unloading litters in a CBRN environment. This training will enhance their ability to perform the task of transporting patients correctly and using the proper techniques will reduce fatigue and the risk of injury. In the maneuver battalion, they are called nonmedical patient decontamination site (PDS) nonmedical augmentees. (See appendix E.)			
3. Select site and set up decontamination area: a. Set up the clean side of decontamination station upwind of the contaminated areas. b. Set up the shuffle pit as the only point of access between the decontamination area and the clean waiting and treatment area. c. Set up the protective shelter on the upwind side of the clean waiting and treatment area. d. Set up the evacuation holding area. e. Marked the hot line. f. Established ambulance points on both the "clean" and "dirty" evacuation routes. g. Set up a contaminated dump. h. Placed chemical agent alarms upwind from the clean treatment area. i. Camouflaged areas according to the tactical standard operation procedures (TACSOP).			
Legend: + indicate critical steps * indicate leader steps; plus signs			

This page intentionally left blank.

Appendix C

Patient Evacuation

This appendix provides medical and casualty evacuation capabilities to assist the medical platoon and planners in determining capacity based on the number and type of vehicles available.

ARMY MEDICAL EVACUATION CAPABILITIES

C-1. Table C-1 provides a graphical representation of the Army MEDEVAC capabilities by vehicle platform.

Table C-1. Army medical evacuation capabilities

<i>Medical evacuation vehicle</i>	<i>Evacuation capacity</i>		
Vehicle	Litter	AMB	Combination
HMMWV M997 series	4	2	2 Litter/ 3 AMB
M113A3 tracked ambulance	4	6-8	2 Litter/ 3-4 AMB
M1133 Stryker MEV	4	6	2 Litter/ 2-4 AMB
M1266A1 LWB MRAP ambulance	2	4	1 Litter/ 2 AMB
AMPV medical evacuation	4	6	2 Litter/ 3 AMB
UH-60	6	7	Varies
UH-72	2	3	Varies
Legend: AMB ambulatory AMPV Armored Multi-Purpose Vehicle HMMWV High Mobility Multipurpose Wheeled Vehicle LWB long wheel base MEV medical evacuation vehicle MRAP Mine-Resistant Ambush Protected UH utility helicopter			

ARMY CASUALTY EVACUATION CAPABILITIES

C-2. Table C-2 on page C-2 provides a graphical representation of the Army CASEVAC capabilities by vehicle platform.

Table C-2. Army casualty evacuation capabilities

<i>Casualty evacuation vehicle</i>	<i>Evacuation capacity</i>		
	<i>Litter</i>	<i>AMB</i>	<i>Combination</i>
HMMWV M998 series	3	5	Varies with configuration
M1081 LMTV	7	12	
M1093 MTV	8	14	
M977A4 HEMMT	9		
M871 22 1/2 ton cargo trailer	16		
CH-47 (Multiple evacuation configurations with litter support kit installed)	0	31	
	4	25	
	8	19	
	12	16	
	16	10	
	20	4	
C-12 Huron	0	8	
	2	4	
Legend:			
AMB	ambulatory		
CH	cargo helicopter		
HEMTT	heavy expanded, mobility tactical truck		
HMMWV	high mobility multipurpose wheeled vehicle		
LMTV	light medium tactical vehicle		
MTV	medium tactical vehicle		

SERVICE MEDICAL SUPPORT TO UNITED STATES ARMY

C-3. The United States Army possesses flexible and robust medical capabilities however, situations will occur where Army medical planners may have to plan, coordinate, and synchronize HSS with other Service medical capabilities. Basic medical information is outlined below but planners may also refer to the respective Service publications for greater detail.

UNITED STATES MARINE CORPS AND NAVY CAPABILITIES

C-4. The United States Army's ability to conduct LSCO in environments such as the Indo-Pacific region (which encompasses roughly 52 percent of the Earth's surface area) will require United States Navy support. Table C-3 on page C-3 provides information to assist Army medical planning efforts regarding United States Navy evacuation.

C-5. The Navy does not operate dedicated rotary wing AE ambulances. When available, however, the Navy helicopter sea combat squadrons can utilize search and rescue medical technicians to provide enhanced care during evacuation. Navy and

Marine CASEVAC capabilities are provided in table C-3. For more information on United States Navy and Marine Corps patient movement, see NTTP 4-02.2M/MCRP 3-40A.7.

Table C-3. United States Navy and Marine Corps casualty evacuation capabilities

<i>Casualty Evacuation Vehicle</i>	<i>Evacuation Capacity</i>	
AIRCRAFT		
Vehicle	Litter	AMB
UH-1Y Huey	6	10
CH-46 Sea Knight	15	22
CH-53 Sea Stallion	24	37
V-22 Osprey	12	24
GROUND		
MRAP CAT II ISS	0	4
LAV 25	0	4
LAV-L	4	7
MK 23 (7-Ton Truck)	10	20
Note. Vehicles used by Army and other Services are included in Army casualty evacuation capabilities.		
Legend:		
AMB ambulatory	LAV light armed vehicle	
CAT category	LAV-L light armored vehicle-logistics	
CH cargo helicopter	MRAP Mine-Resistant Ambush Protected	
ISS independent suspension system	UH utility helicopter	

C-6. Army forces operating in the Pacific may not be able to establish a Role 2 or Role 3 medical unit until initial lodgments are secured or expanded. As a result, United States Navy ships may provide the initial Role 2, Role 3, or surgical capability afloat. Table C-4 (see pages C-4 through C-5), provides medical treatment capability and capacity organized by ship. For additional information on United States Navy and United States Marine Corps medical capabilities, see NTTP 4-02.2M/MCRP 3-40A.7.

C-7. Army forces operating in the Pacific may not be able to establish Role 2 or Role 3 medical units until initial lodgments are secured or expanded. As a result, United States Navy ships may provide the initial Role 2, Role 3, or surgical capability afloat. Table C-4 (see pages C-4) provides medical treatment capability and capacity organized by ship. For additional information on United States Navy and United States Marine Corps medical capabilities, see NTTP 4-02.2M/MCRP 3-40A.7.

Table C-4. United States Navy ship capabilities and staffing

Aircraft Carrier Capabilities and Staffing			
CV/CVN Capability	Nimitz Class Staffing	Ford Class Staffing	
Operating Rooms	1	1	
Intensive Care Units Beds	3	3	
Ward Beds	48	32	
Ancillary Capabilities	Laboratory, blood bank, x-ray, pharmacy, preventive medicine, biomedical repair, and aviation physical examinations.		
Medical Corps	6	6	
Dental Corps	5	5	
Nurse Corps	2	2	
Medical Service Corps	5	5	
Hospital Corpsmen	45	38	
Amphibious Assault Ship Capabilities and Staffing			
LHD/LHA Capability	Ship/FST Staffing	Ship/FST/HSAP Staffing	
Operating Rooms	1	1	
Intensive Care Units Beds	3	3	
Ward Beds	48	32	
Ancillary Capabilities	Laboratory, x-ray, pharmacy, preventive medicine, biomedical repair, aviation physical examinations, radiation health, spectacle fabrication, psychology, and physical therapy.		
	SHIP	FST	HSAP
Medical Corps	2	* 3	11
Dental Corps	1		1
Nurse Corps		* 3	22
Medical Service Corps	1	1	1
Hospital Corpsmen	19	9	49
* Includes certified registered anesthesiologist or nurse anesthetist.			
Legend:			
CV	aircraft carrier	HSAP	Health Service Augmentation Program
CVN	aircraft carrier, nuclear	LHA	amphibious landing ship (general purpose)
FST	fleet surgical team	LHD	amphibious landing ship (multipurpose)

Table C-4. United States Navy ship capabilities and staffing (continued)

<i>Amphibious Transport Dock (LPD) Staffing</i>		
LPD Capability	Austin Class	San Antonio Class
Operating Rooms	0	1
Intensive Care Units Beds	** 17	** 24
Ward Beds	48	32
Ancillary Capabilities	Laboratory and x-ray	Laboratory and x-ray
Medical Corps	1	1
Dental Corps	1	1
Hospital Corpsmen	9	15
** Capability requires augmented staff.		
<i>Landing Ship Dock (LSD) and Staffing</i>		
LSD Capability		
Ward beds		** 8
Ancillary capabilities		Laboratory and x-ray
Medical corps		1
Dental corps		1
Hospital corpsmen		5
** Capability requires augmented staff.		
<i>Submarine Tender Capabilities and Staffing</i>		
Operating rooms		2
Ward beds		12
Ancillary capabilities		Laboratory, x-ray, and pharmacy
Medical corps		1
Dental corps		3
Hospital corpsmen		18
<i>Hospital Ship (T-AH) Capabilities and Staffing</i>		
Operating rooms		12
Intensive care units beds		80
Ward beds		1,000
Isolation ward		1
Ancillary capabilities	Laboratory, four radiology suites and one CAT scan, invasive angiography suite, pharmacy, blood bank, dental suite, preventive medicine, medical equipment repair shop, aviation physical examinations, prosthetics, optometry and lens laboratory, psychology, and physical therapy.	
Full operating status medical staff/crew	1,200 plus 71 civil service mariners	

UNITED STATES AIR FORCE CAPABILITIES

C-8. Table C-5 depicts Air Force fixed-wing aircraft capacities. Take note of the floor loading capacities which would be used as opportune lift for casualties in more hostile environments.

C-9. For more information on aircraft capacities in support of aeromedical evacuation operations, see Air Force Manual 11-2 AEV3, Addenda-A.

Table C-5. United States Air Force aircraft capacities

<i>Aircraft</i>	<i>AE Configuration</i>	<i>AE-1</i>	<i>AE-2</i>	<i>AE-3</i>	<i>AE-4</i>	<i>AE-5</i>	<i>AE-6</i>
C-130 H/J	Litter Spaces	30	72/92 (J-30)	20	50/60 (J-30)	10	15/21** (J-30)
	Total Seats *	46/62 (J-30)	6/10 (J-30)	44/62 (J-30)	30/62 (J-30)	31/45 (J-30)	
C-17	Litter Spaces	9	36	9	6	48***	
	Total Seats	54	54	90	49		
KC-135	Litter Spaces	6	9	15	8**		
	Total Seats	31	28	20			
KC-46A	Litter Spaces	24**					
	Total Seats	30					
C-12J	Litter Spaces	1					
	Total Seats	10					
C-21	Litter Spaces	1					
	Total Seats	5					
<p>Note.</p> <p>* Actual seats may decrease based on crew complement, mission requirements, and patient load.</p> <p>** Floor loading</p> <p>*** Floor loading with up to 12 litter patients placed on the ramp for maximum utilization of the aircraft.</p>							
<p>Legend:</p> <p>AE aeromedical evacuation</p>							

ESTABLISHING A HELICOPTER LANDING ZONE

C-10. Helicopter landing zones contain one or more helicopter landing sites. Each landing site has a control center and, in most cases, a manned or unmanned release point (STANAG 3619). Each landing site might have one or more specific landing points for individual aircraft to touch down. Refer to FM 3-21.38 for more information.

TACTICAL CONSIDERATIONS

C-11. Tactical considerations are those that pertain to the actual mission of the supported ground unit. These considerations are the responsibility of the ground unit commander and staff. The pathfinder must understand the ground tactical plan to best support the ground unit and facilitate mission accomplishment. These include—

- An estimate of the situation based on METT-TC.
- The location of the objective in relation to the tentative HLZ.
- The size and type of unit being supported.

TECHNICAL CONSIDERATIONS

C-12. These pertain to the technical aspect of the operation of a day or night HLZ. These are the responsibility of the individual establishing the HLZ. The minimum landing space requirements and minimum distance between helicopters on the ground depend on many factors. If the aviation unit SOP fails to spell out these requirements, the aviation unit commander works with the unit leadership. The final decision about minimum landing requirements rests with the aviation unit commander. In selecting helicopter-landing sites from maps, aerial photographs, and actual ground or aerial reconnaissance, the medical platoon leadership considers the following factors listed in table C-5 on page C-6, and in table C-6.

C-13. In a landing site, personnel designated to establish the HLZ measure the minimum distances between landing points, from center to center. When aircraft sizes vary, Soldiers separate landing points by the most generous measure, allowing 100 meters for size 5; 125 meters for size 6; 150 meters for size 7, measured center to center on the landing points (see figure C-1 on page C-8).

Table C-6. Landing point uses

<i>Landing point</i>	<i>Minimum diameter of landing point</i>	<i>Type of helicopter/operation</i>
Size 1	80 ft (25 m)	Light observation helicopters such as the OH-6.
Size 2	125 ft (35 m)	Light utility and attack helicopters such as the UH-1H and AH-1W.
Size 3	160 ft (50 m)	Medium utility and attack helicopters such as the UH-60 and AH-64.
Size 4	265 ft (80 m)	Cargo helicopters such as the CH-47 and CH-53, or with prior coordination.
Size 5	328 ft (100 m)	Sling load helicopters and aircraft of an unknown origin.
Size 6	410 ft (125 m)	Sling load long-line operations.
Size 7	492 ft (1,505 m)	Sling load operations with night vision goggles.
Legend:		
AH	attack helicopter	m meter
CH	cargo helicopter	NVG night vision goggles
ft	feet	OH observation helicopter

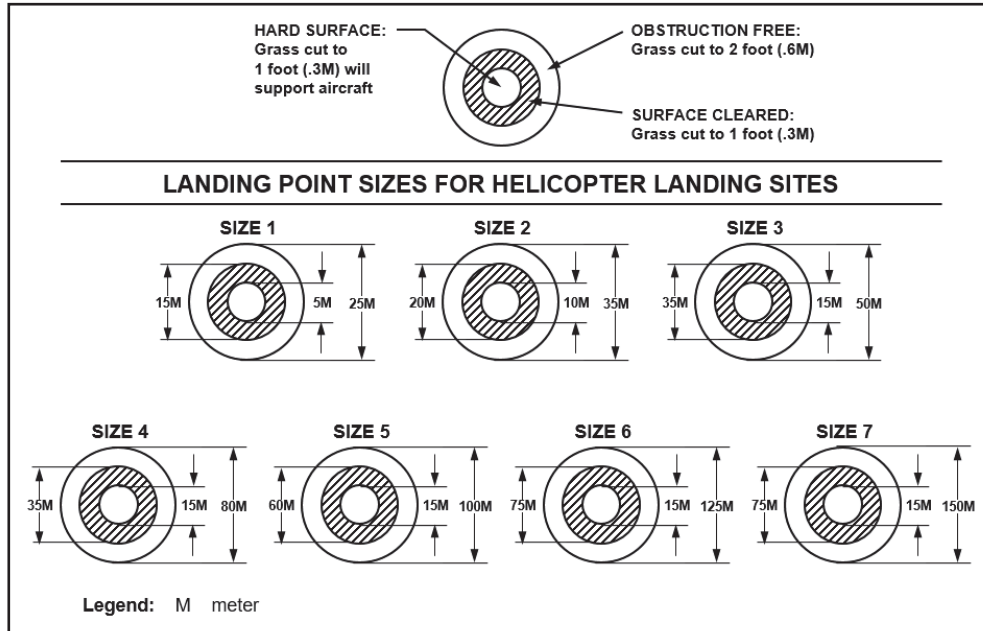

Figure C-1. Landing point sizes

Appendix D

Force Health Protection and Medical Readiness

The mission of the medical platoon is not just medical treatment and evacuation. The mission begins at home station. The medical platoon leadership is responsible for coordinating with many personal, special, and coordinating staffs in the battalion. Many of these tasks fall within the protection warfighting function. Discussed below are many of the tasks and functions the medical platoon is responsible for pre-, during-, and postdeployment.

Nested within FHP is medical readiness. Medical readiness is the functions that conserve the fighting strength of the battalion such as periodic medical assessments, immunizations, and dental care to name a few.

SECTION I – FORCE HEALTH PROTECTION

D-1. Force health protection is a continuous process that begins with the Soldier's entry into the military and continues throughout the Soldier's military career. Force health protection includes establishing a healthy and fit force by sustaining health promotion and nutrition programs, the identification of the health threat in all settings (in both deployed and garrison settings), the development and implementation of personnel protective measures to reduce exposure to health hazards, and mitigating the adverse effects of the impact of health threats to military personnel.

D-2. Force health protection is one of the major components of AHS and one of the primary tasks of the protection warfighting function. It consists of the following five medical functions:

- Dental services.
- Operational public health.
- Combat and operational stress control.
- Veterinary services.
- Medical laboratory services.

D-3. The medical platoon facilitates FHP for the battalion by accomplishing the list of tasks in table D-1 on page D-2.

Table D-1. Medical platoon force health protection responsibilities

<i>Coordinating staff supported</i>	<i>Medical platoon responsibilities</i>
Battalion commander/ executive officer	Monitors the health of the command and advises the commander on measures to counter disease and injury threats.
Battalion commander/ executive officer	Advises the commander on the overall health of the command.
Chief of Protection (Battalion Operations Officer)	Participates in the protection cell working group to— <ul style="list-style-type: none"> • Integrate and synchronize Force Health Protection (FHP) tasks and systems for each phase or transition of an operation or major activity. • Provide the chief of protection with FHP input for Annex E (Protection), Appendix 9 (FHP).
Chief of Protection (Battalion Operations Officer)	Monitors and coordinates FHP operations. Coordinates FHP to include dental services, operational public health, COSC, veterinary services, and medical laboratory services.
Chief of Protection (Battalion Operations Officer)	Periodic health assessment (PHA) tracking/reporting. Provides first sergeants (1SGs) weekly PHA statistics.
Chief of Protection (Battalion Operations Officer)	Dental readiness tracking/reporting. Provides 1SGs weekly dental readiness statistics. Also, coordinates with the brigade support medical company (BMSC) about scheduling Soldiers through the dentist to conduct annual exams while in a deployed setting or requests the BMSC to set up their dental tent in the battalion area to conduct annual exams.
Chief of Protection (Battalion Operations Officer)	Immunizations and vaccines. Considers a monthly immunization clinic. Runs a medical protective system (MEDPROS) report and let the 1SGs know who is due for immunizations that month. Alternatively, if not battalion-wide, picks one company per month and concentrate on their immunizations.
Chief of Protection (Battalion Operations Officer)	Ensures the battalion maintains a list of blood types.
Chief of Protection (Battalion Operations Officer)	Hearing Readiness and Operational Hearing Services. Tracks and reports hearing status of battalion personnel and addresses operational noise negatively impacting Soldiers, such as generators placed near sleeping quarters. Hearing and accurate communication are combat multipliers key to Soldier lethality and survivability.
Chief of Protection (Battalion Operations Officer)	Vision readiness. Tracks and reports vision readiness of battalion personnel.

**Table D-1. Medical platoon force health protection responsibilities
(continued)**

<i>Coordinating Staff Supported</i>	<i>Medical Platoon Responsibilities</i>
Chief of Protection (Battalion Operations Officer)	Coordinates other "routine" medical readiness requirements with the BMSC or other echelons above brigade medical assets during field training exercises, such as an optometry team to do annual vision exams or a preventive medicine detachment conducts field sanitation team refresher training using field conditions as the training aid.
Chief of Protection (Battalion Operations Officer)	Advises how operations affect the public health of personnel and the indigenous populations.
Chief of Protection (Battalion Operations Officer)	Coordinates with medical detachment, veterinary service support for government owned animal veterinary medical care and transport to Army veterinary service's location for treatment.
Chief of Protection (Battalion Operations Officer)	Monitors the command operational public health program to include health risk assessment and medical surveillance.
Chief of Sustainment (Battalion Logistics Officer)	Plans for and implements operational public health (including initiating measures to counter the health threat, and establishing medical and occupational and environmental health surveillance).
Chief of Sustainment (Battalion Logistics Officer)	Coordinates for food and water inspections.
CBRN Officer	Coordinates Army Health System support requirements for chemical, biological, radiological, and nuclear operations. (Annex E (Protection, Appendix 10).
Chaplain	Coordinates the employment of combat and operational stress control teams with the chaplain to best meet the needs of battalion personnel for stress control.

SECTION II – MEDICAL READINESS

D-4. *Medical readiness* is a standardized system across the total force to enable the commander to measure, achieve, and sustain Soldiers' health to perform their war time requirement (MOS/AOC) from induction to separation (AR 40-502). See AR 40-502 for more information on medical readiness.

D-5. The battalion commander is charged with the health and welfare of all those assigned and/or attached to their battalion. The medical platoon facilitates this by developing TTP that track, report, and conduct medical readiness activities for the battalion commander. For example, the medical platoon will gather reports from MODS and the supporting dental clinic on next month's delinquencies for periodic health

assessment (PHA), immunizations, and dental. This information is broken down by company and given to company senior medics to disseminate to the unit leadership for action. The medical platoon then tracks and reports medical readiness data during monthly battalion-level briefings to the battalion commander.

MEDICAL READINESS CLASSIFICATION

D-6. Medical readiness classification (MRC) is an administrative determination by health care providers using a standardized system across the total force. This system enables the commander to measure, achieve, and sustain their Soldiers' health and ability to perform their wartime requirement in accordance with their military occupational specialty (MOS)/area of concentration (AOC) from induction to separation. Medical readiness is described in AR 40-502, chapter 2.

D-7. Commanders administratively use the medical readiness information to determine if a Soldier is deployable and able to perform the unit's core designed mission or assigned mission in accordance with readiness reporting guidance in AR 220-1 and DA Pam 220-1. Soldiers are automatically medically deployable in the Medical Readiness System of Record if they are in MRC 1 or 2. This status is automatically uploaded to the readiness reporting system without additional commander action. Commanders can make deployability determinations for readiness reporting on Soldiers who are in MRC 3, with deployment-limiting (DL) 1 and 2, as well as for Soldiers in MRC 4. Deployment limiting codes 3 to 7 are constrained by policy from deployment, and cannot be overridden by commanders.

D-8. Upon receipt of an assigned mission, the battalion surgeon or servicing health care provider will evaluate the Soldiers to determine if they meet the combatant command's (CCMD) deployment requirements or require a waiver. Combatant commanders establish their deployment status guidance and processes. Combatant commander waivers do not influence a Soldier's medical readiness. Permanent and temporary conditions with DL codes 1, 2, and 7 may be evaluated for CCMD waiver requests. Conditions that do not meet CCMD deployment criteria, but otherwise do not require a profile (for example, excessive body mass index) will receive a temporary profile until the CCMD waiver is complete. Listed below are areas of emphasis for units commands:

- In making deployability determinations, unit commanders should consider the Soldier's skills, responsibilities, duties, type of mission, and geographic conditions/concerns. Additionally, commanders should ensure close collaboration with unit supporting or healthcare providers in making their deployability determination.
- The Commander Portal records deployable personnel determinations for Soldiers with duty limitations and an indeterminate status. The Medical Readiness System of Record feeds the deployability determinations to the Army Readiness.
- The electronic profiling system annotates on the profile when the commander reviews the Soldier's profile.
- Unit commander's deployable personnel determinations for their Soldiers in MRC 3, DL 1, and DL 2 are independent of the assessment and requirements

for deployment medical waivers in accordance with CCMD specific guidance.

D-9. Specific medical readiness criteria can be addressed in detail in AR 40-502, chapters 2 through 5.

INDIVIDUAL MEDICAL READINESS KEY ELEMENTS

D-10. The medical platoon facilitates the following six DOD individual medical readiness (IMR) elements for the battalion's assigned and/or attached personnel:

- Periodic health assessment.
- Deployment-limiting conditions.
- Dental readiness.
- Immunization status.
- Medical readiness laboratory tests.
- Individual medical equipment.

D-11. The medical platoon also tracks two additional Army-specific requirements:

- Hearing readiness.
- Vision readiness.

D-12. To be medically ready, all Soldiers must maintain these eight IMR elements. With regards to the deployment-limiting conditions IMR element, Soldiers must meet AR 40-501 retention standards or have completed a boarding action that returned them to duty without a deployment-limiting physical category code. Department of the Army Pamphlet 40-502 describes the medical administrative processing after completion of a medical or administrative board. Soldiers who do not meet medical retention standards are not medically ready. They should be referred for disability evaluation system processing in accordance with the eligibility provisions of AR 635-40, and by DOD disability evaluation system policy (see DODI 1332.18). Soldiers use the medical protection system (MEDPROS) to electronically complete their DD Form 3024 (*Annual Periodic Health Assessment*).

INDIVIDUAL MEDICAL READINESS CLASSIFICATION

D-13. After evaluating the required IMR elements by viewing e-Profile, the Medical Readiness System of Record and the electronic health record information, the health care team will categorize the Soldier into one of four medical readiness categories listed below and depicted in table D-2 on pages D-6 through D-7.

MEDICAL READINESS CLASS 1 (FULLY MEDICALLY READY)

D-14. Soldiers in this class are current in PHA (completed), dental readiness assessment classified as Dental Class 1 or 2, immunization status, medical readiness and laboratory studies, individual medical equipment, and without any deployment-limiting medical conditions or medications and are considered MRC 1.

MEDICAL READINESS CLASS 2 (PARTIALLY MEDICALLY READY)

D-15. Soldiers in this class are lacking one or more immunizations, medical readiness laboratory studies, Hearing Readiness Class 4, Vision Readiness Class 4, and/or individual medical equipment and are considered MRC 2.

MEDICAL READINESS CLASS 3 (NOT MEDICALLY READY)

D-16. Soldiers in this class have a deployment-limiting condition described by the deployment-limiting codes 1 through 7. This may include chronic or prolonged deployment-limiting medical or mental conditions, serious illness or injury with associated hospitalization and recovery time, and dental readiness classification (DRC) 3 dental conditions and are considered MRC 3.

MEDICAL READINESS CLASS 4 (MEDICAL READINESS INDETERMINATE)

D-17. This class includes those Soldiers whose current health status is indeterminate because of missing health information, including Soldiers with an overdue PHA, and/or those in Dental Class 4 and are considered MRC 4.

Table D-2. Medical readiness classification chart

<i>MRC</i>	<i>Short definition</i>	<i>Medical definition</i>	<i>Commander deployment status personnel determination</i>
MRC 1	Medically ready/ deployable	Meets all medical readiness requirements and DRC 1 or 2 <ul style="list-style-type: none"> • Temporary profile ≤ 7 days 	Not required.
MRC 2	Partially medically ready/ deployable	Soldier is deficient in one or more of the following: <ul style="list-style-type: none"> • Temporary profile between 8 and 30 days inclusive • Hearing Readiness Class 4 (current within 13 months) • Vision Readiness Class 4 (current within 15 months) • DNA (drawn/on file with DOD Repository) • HIV (drawn/validated with DOD Repository) • Immunizations current or valid exception (routine adult immunization profile, to include HepA, HepB, TD or TDaP, MMR, polio, varicella, influenza-seasonal and, if required rabies) • Individual medical equipment if required; 1 MI, 2 pair eye glasses, MCEP-I, MWT, and hearing aid with batteries 	Not required, default to deployable. Commanders may make a deployability determination that a Soldier with a temporary profile between 14 and 30 days is not deployable.

Table D-2. Medical readiness classification chart (continued)

<i>MRC</i>	<i>Short definition</i>	<i>Medical definition</i>	<i>Commander deployment status personnel determination</i>																																				
MRC 3	Not medically ready/commander determines deployment status for: —Temporary profile >30 days (DL 1) —DRC 3 (DL 2)	Soldier is deficient in one or more of the following: <ul style="list-style-type: none"> • DL 1—Temporary profile > 30 days • DL 2—DRC 3 • DL 3—Pregnancy or post-partum • DL 4—Permanent profile indicating a MAR2 needed • DL 5—Permanent profile indicating a MEB action is needed • DL 6—Permanent profile indicating a non-duty related action is needed • DL 7—Permanent profiles with a deployment/assignment restriction code (F, V, X, or Y) 	DL 1 and 2: Soldier is not medically ready/commander determines deployment status. DL 3, 4, 5, and 6: Soldier is not medically ready/non-deployable. Unit commander cannot make a deployability determination for routine readiness re-reporting. DL 7: Soldier is not medically ready/non-deployable. Unit commander cannot make a deployability determination for routine readiness reporting. Upon receipt of an assigned mission, deployment status will be in accordance with CCMD policies.																																				
MRC 4	Not medically ready/deployable and commander determines deployment status (default nondeployable)	Status is unknown Soldier is deficient in one of the following: <ul style="list-style-type: none"> • PHA (current within 15 months) • DRC 4 (current within 15 months) 	Soldier is not medically ready/deployable and commander determines deployment status.																																				
<p>Legend:</p> <table border="0"> <tr> <td>CCMD</td> <td>combatant command</td> <td>MCEP-I</td> <td>military combat eye protection</td> </tr> <tr> <td>DL</td> <td>deployment-limiting</td> <td>MEB</td> <td>medical evaluation board</td> </tr> <tr> <td>DNA</td> <td>deoxyribonucleic acid</td> <td>MI</td> <td>mask insert</td> </tr> <tr> <td>DOD</td> <td>department of defense</td> <td>MMR</td> <td>measles, mumps, and rubella</td> </tr> <tr> <td>DRC</td> <td>dental readiness classification</td> <td>MRC</td> <td>medical readiness classification</td> </tr> <tr> <td>HepA</td> <td>hepatitis A</td> <td>MWT</td> <td>medical warning tags</td> </tr> <tr> <td>HepB</td> <td>hepatitis B</td> <td>PHA</td> <td>periodic health assessment</td> </tr> <tr> <td>HIV</td> <td>human immunodeficiency virus</td> <td>TD</td> <td>tetanus-diphtheria adult</td> </tr> <tr> <td>MAR2</td> <td>Military Occupational Specialty Administrative Retention Review</td> <td>TDaP</td> <td>tetanus, diphtheria, and acellular pertussis</td> </tr> </table>				CCMD	combatant command	MCEP-I	military combat eye protection	DL	deployment-limiting	MEB	medical evaluation board	DNA	deoxyribonucleic acid	MI	mask insert	DOD	department of defense	MMR	measles, mumps, and rubella	DRC	dental readiness classification	MRC	medical readiness classification	HepA	hepatitis A	MWT	medical warning tags	HepB	hepatitis B	PHA	periodic health assessment	HIV	human immunodeficiency virus	TD	tetanus-diphtheria adult	MAR2	Military Occupational Specialty Administrative Retention Review	TDaP	tetanus, diphtheria, and acellular pertussis
CCMD	combatant command	MCEP-I	military combat eye protection																																				
DL	deployment-limiting	MEB	medical evaluation board																																				
DNA	deoxyribonucleic acid	MI	mask insert																																				
DOD	department of defense	MMR	measles, mumps, and rubella																																				
DRC	dental readiness classification	MRC	medical readiness classification																																				
HepA	hepatitis A	MWT	medical warning tags																																				
HepB	hepatitis B	PHA	periodic health assessment																																				
HIV	human immunodeficiency virus	TD	tetanus-diphtheria adult																																				
MAR2	Military Occupational Specialty Administrative Retention Review	TDaP	tetanus, diphtheria, and acellular pertussis																																				

RESPONSIBILITIES

D-18. Commander's responsibilities for medical readiness are discussed below.

BATTALION COMMANDERS OR EQUIVALENT

D-19. The battalion commanders or equivalent will—

- Review the unit medical readiness and deployment status of subordinate units.
- Mentor unit commanders regarding deployability determinations and command support of medical readiness.
- Participate in profile review boards as outlined in DA Pam 40-502.
- Appoint dedicated medical protection system unit managers and commander clerks at battalion headquarters to track Soldier and unit medical readiness.
- Use the Commander Portal to perform a monthly review of temporary profiles lasting 120 days or more as described in DA Pam 40-502.

UNIT COMMANDERS

D-20. The unit commanders will—

- Establish a command expectation that individuals will be personally responsible for meeting and maintaining IMR requirements.
- Monitor individual and unit IMR status using the Commander Portal as described in DA Pam 40-502. Commanders will take action when unit members fail to respond to notifications of due or overdue IMR requirements or fail to keep scheduled appointments to ensure the unit meets the published medical readiness goal.
- Ensure unit medical readiness; determine deployable personnel when informed by medical readiness information and administration; and report unit readiness in accordance with AR 220-1 on the Commander Portal.
- Appoint formally a commander's designee who is a trusted and trained individual as an alternate to execute command readiness responsibilities. Commander designees will obtain system access after completing all training required for access to the Commander Portal.
- Allocate adequate duty time for Soldiers to meet and maintain IMR requirements.
- Ensure processes are in place and functioning to notify Soldiers of due and overdue IMR requirements and deployment-related health assessments completion.
- Review all physical profiles describing duty limitations within 14 days after a profiling officer issues a profile (30 days for RC) and make deployability determination on all profiles not constrained by regulation or policy for all Soldiers in their command through the Commander Portal.
- Complete Commander Portal training and obtain system access no later than 14 days (RA) or 30 days (RC) after assuming their duties.

- Ensure Soldiers assigned to deploy with their unit receive deployment health assessment screenings and maintain readiness throughout the deployment cycle.
- Ensure Soldiers' deployment, movement, and geographical area medical readiness requirements are met. Commanders will ensure all Soldiers have access to the appropriate systems to complete the individual portion of all deployment health assessment forms.

D-21. The Soldiers and other deployable personnel will—

- Monitor and maintain currency of medical readiness requirements. Reserve component personnel may have to accomplish some IMR requirements on their own time such as civilian dental exams or medical evaluations.
- Complete all deployment health assessment program assessments on the required forms, within the published timelines, in accordance with DODI 6490.03 and current Army policy.
- Report medical (including mental health) and health issues that may affect their readiness to deploy or fitness to continue serving in an active status per DODI 6025.19.

SECTION III – MANAGEMENT OF DEPLOYED INDIVIDUAL HEALTH RECORDS

D-22. The purpose of a medical record is to document patient encounters, health assessments, potential exposures to toxic industrial materials or CBRN warfare agents and concussive incidents, treatments received, and medications provided. The longitudinal medical record is initiated when a Soldier joins the Service and continues through the Soldiers' entire military career. It is essential that the individual medical record be comprehensive and captures all required data for medical-legal purposes, research, and education and aids in determining military retention, eligibility for benefits, and readiness for mobilization. Medical records may be handwritten or electronic. The electronic medical record is the preferred method for compiling a health record; however, in some deployed settings it may not be available at all roles of care. When using handwritten documentation, care must be taken to ensure the documentation accompanies the patient through the evacuation process. This appendix provides guidance on the maintenance of the Soldier's individual health record (HREC) (handwritten) while deployed. The governing regulation for health care documentation is AR 40-66.

MEDICAL RECORDS TRAINING

D-23. Patient administrators will establish training programs for Role 1 BAS personnel. Training should encompass but not be limited to rotations in nearest installation MTF PAD section. The goal is to improve Soldier skills that will be used in support of deployed unit operations.

D-24. As applicable, training should also increase proficiency/familiarization in the use of applicable automation systems such as the Composite Health Care System, Joint

Patient Tracking Application, the Patient Administration Systems and Biostatistics Activity tool, and the Transportation Command Regulating and Command & Control System.

D-25. Through the brigade surgeon, upon alert for deployment the Role 1 BAS will notify the Chief, Data Management Branch, PASBA at USAMEDCOM who will forward the medical platoon a deployment package including applicable ARs, users' manuals, and required reports/tools. Any training requirements for the deployment unit will be discussed at that time.

MAINTENANCE OF HEALTH RECORDS

D-26. Health records are normally maintained by the installation MTF that provides primary care for the Soldier.

D-27. Unit commanders will ensure that HRECs are always available to Army Medicine personnel who require such records in the performance of their duties. Unit commanders will also ensure that the information in the HRECs is kept private and confidential in accordance with law and regulations governing patient records administration.

D-28. Health records located at Role 1 BAS are maintained by unit medical personnel. The senior Army Medicine officer usually serves as the custodian of the HRECs. Army Medicine officers are in charge of the HRECs for the members of the units for whom they supply primary medical care. They are also in charge of the HRECs, and the records of other individuals that are receiving treatment from the BAS. Health records are important for the conservation and improvement of the patient's health. Therefore, medical platoon personnel will ensure that all pertinent information is promptly entered in the HREC in their custody. If any such pertinent information has been omitted, the battalion surgeon will take immediate action to obtain such information from the proper authority and include it in the HREC.

D-29. The Health Insurance Portability and Accountability Act of 1996 provides for the privacy rights and protection of health information of Soldiers while ensuring necessary and required health/medical information is accessible to medical personnel and other appropriate entities. This applies whether the Soldier is deployed or at home station, whether it is written, verbal, or in digital format.

D-30. Detainees are afforded safeguards to patient confidences and privacy within constraints of U.S. law, whether the information is entered in electronic format, written down, or verbally presented. Medical records for enemy prisoners of war and/or detainees will be identified by the interment serial number. If an interment serial number has not been assigned, the individual will be identified by the capture tag number. Once the individual has been processed by the theater interment facility, they will be assigned their interment serial number and the HREC is annotated appropriately.

HEALTH RECORDS FOR DEPLOYED SOLDIERS

D-31. The HREC of deployed Soldiers will not accompany them to the combat area. The supporting installation MTF will initiate the following forms:

- DD Form 2766 (*Adult Preventive and Chronic Care Flowsheet*).
 - DD Form 2766C (*Adult Prevention and Chronic Care Flowsheet [Continuation Sheet]*).
 - DD Form 2795 (*Pre-Deployment Health Assessment*).
 - DD Form 2796 (*Post Deployment Health Assessment [PDHA]*).
-

Note: DD Form 2795 and DD Form 2796 are completed electronically through the MEDPROS.

D-32. If an individual deploys, the DD Form 2766 and DD Form 2766C will be photocopied prior to deployment and the copy will be kept in the individual's medical record. The original DD Form 2766 and any DD Forms 2766C will accompany the individual on the deployment. The DD Form 2766 serves as the treatment folder for the individual that is deployed. Other forms that can be included are:

- DD Form 2766C.
 - SF 600 (*Chronological Record of Medical Care*).
-

Note: DD Form 2005 (*Privacy Act Statement – Health Care Records*), should be included in each deployed medical record.

D-33. These forms will be filed inside DD Form 2766. The photocopies of the DD Form 2766 and DD Form 2766C will be removed and shredded when the originals are placed back into the HREC. Forms that had been filed inside the DD Form 2766 folder will be removed and placed in the HREC.

D-34. When processing individuals for deployment, the MTF and dental treatment facility will audit each individual's HREC and record essential health and dental care information on DD Form 2766. If a HREC is not available, DD Form 2766 will be completed based on individual interviews and any other locally available data. A HREC may not be available for most individual ready reserve, individual mobilization augmentees, and retired personnel because these HREC may remain on file at the Human Resources Command or the Department of Veterans Affairs. Upon notification of deployment, all military personnel will complete DD Form 2795. A copy of the form will be filed on the fastener inside the DD Form 2766 folder; one copy will remain in the HREC and the original form will be sent to the Armed Forces Health Surveillance Center.

D-35. If the deployed individual is taking part in a classified operation, the DD Form 2795 is still required to be completed electronically. See AR 40-66 for more information on disclosure of medical records containing classified defense information.

D-36. The completed DD Form 2766 and a copy of any printout from an automated immunization tracking system will be provided to the individual's command or to the individual if they are an individual replacement, and then handed off to the MTF in the AO responsible for providing primary medical care to that individual. That MTF will

maintain the DD Form 2766 as an outpatient field file for reference as needed. The MTF will ensure that the blood type from a verified blood bank typing is recorded accurately. The field file will consist of, in part the following forms:

- DD Form 1380.
- DD Form 2766, and possibly DD Form 2766C.
- SF 558 (*Medical Record, Emergency Care and Treatment [Patient]*).
- SF 600
- SF 603 (*Health Record – Dental*).

D-37. These forms will be filed inside the DD Form 2766. If DD Form 2766 is not available, the Soldier's field file may be managed as a drop file (forms not attached) and integrated into the DD Form 2766 when it is available.

D-38. If required, TOE units may be responsible for submitting daily joint patient tracking application and patient status reports via the patient administration systems and biostatistics activity tool electronically to patient administration systems and biostatistics activity or by using the worldwide workload reporting function in the TOE automated patient tracking systems.

LIMITED CONTINGENCY OPERATIONS

D-39. Retain the HREC at the BAS and dental treatment facility providing primary care. If the servicing primary care facility closes, forward the HREC to the BAS or dental treatment facility indicated by the servicing installation Role 4 installation MTF and dental activity.

USE OF FIELD FILES/DD FORM 2766

D-40. If a Soldier's primary MTF changes, the field file/DD Form 2766 should be moved to the gaining MTF. If a Soldier requires admission to the hospital, every attempt will be made to forward the field file/DD Form 2766. The file will be returned to the member's primary MTF if disposition is RTD.

STORAGE OF HEALTH RECORDS

D-41. The Role 1 BAS will secure field chest or field file containers in quantities sufficient for the battalion. They will maintain the DD Form 2766 for each individual receiving primary medical care from their BAS.

ESTABLISHMENT AND MANAGEMENT OF THE FIELD FILE IN THE OPERATIONAL AREA

D-42. A DD Form 2766 and the medical records identified above will be maintained by the medical platoon that operates a Role 1 BAS, or will be handed off to the installation MTF providing their primary care.

D-43. Supported units will be required to provide the BAS a battle roster of personnel assigned. This roster should be provided when personnel assignment changes are made or upon request.

D-44. The Role 1 BAS, when possible, will attempt to ensure that the HREC accompanies the medically evacuated individual. If an individual's BAS changes, the HREC will be transferred to the gaining unit. If an individual requires hospital admission, every attempt will be made to forward the HREC to the admitting hospital.

D-45. When the BAS determines that an individual was evacuated without the DD Form 2766 and other medical records in the file, then the individual's DD Form 2766 and other medical records are forwarded to the medical C2 headquarters responsible for regulating patients out of the AO. The medical C2 headquarters forwards the outpatient field file to the hospital where the patient was evacuated. The hospital patient administration section will attach the file to the inpatient chart and the file is evacuated with the patient out of the AO or theater of operations.

HEALTH ASSESSMENTS AFTER DEPLOYMENT

D-46. All military personnel will electronically complete a DD Form 2796 prior to leaving the AO.

D-47. If a situation does not allow this health screening prior to departure, the individual's commander will ensure that the health assessment is electronically completed within 30 days of the individual's return.

D-48. The postdeployment assessment of RC personnel must be completed prior to release from active duty if not completed before redeployment. RC personnel who have been deployed will also complete DD Form 2697 (*Report of Medical Assessment*). Reserve Component personnel who are called to active duty but never actually deployed will only complete DD Form 2697.

D-49. If the deployed Soldier is taking part in a classified operation, the postdeployment evaluation (DD Form 2796) is still required to be completed electronically.

FIELD RECORD ADMINISTRATION AFTER HOSTILITIES CEASE

D-50. Field files/DD Form 2766 will be integrated with the HREC after demobilization at the home station or at mobilization stations.

D-51. On return to the BAS (postdeployment), forms, such as SF 600, will be removed from the DD Form 2766 folder and placed with the other SF 600 in the medical record.

D-52. DD Form 2795 and DD Form 2796 will be removed from the DD Form 2766 folder and placed as shown in figures 5-1 on page 50, 5-2 on page 56, or 7-1 on page 86 of AR 40-66. If a previously photocopied DD Form 2795 is contained in the record, only one of the DD Forms 2795 will be kept; the other will be removed and shredded.

D-53. The photocopies of the DD Form 2766 and DD Form 2766C will also be removed and shredded when the originals are placed back into the record. Field files/DD Form 2766 will be forwarded to human resources command (HRC) for those members whose HREC is maintained at HRC.

D-54. Field files will be integrated with the HREC maintained at home station or mobilization station.

This page intentionally left blank.

Appendix E

Medical Training Considerations

The mission of the medical platoon is not just medical treatment and evacuation. It is responsible for the medical training of both its own medical platoon personnel and that of all nonmedical personnel assigned or attached to the battalion. Listed below are many of the trainings requirements the medical platoon is responsible for pre-, during-, and postdeployment.

SECTION I – MEDICAL TRAINING CONSIDERATIONS

E-1. Make every "garrison medical support task" a training event. For example, if an ambulance crew is designated to provide medical support at a range, DZ, or ensure the medics conduct "mission analysis" and pack according to probable injuries instead of just relying on the standard MES, ground ambulance and aid bags. Ensure those medics have an SOP, battle drill, or doctrine and expect an oral summary of what it contained.

E-2. Be involved in maneuver unit training events. Capitalize on every opportunity to participate in company level training. For example, manual carries and litter team training can be concurrent training events at a company small arms range or as an Army physical readiness training event. Establishing a company CCP and exercising CLS personnel can too. Remember, successful medical support is not only training the medical platoon, but also ensuring the maneuver companies are well trained at managing medical support requirements, MASCALs, and conducting CASEVAC. This also includes the specialty platoons in HHC, such as the scouts and mortars.

E-3. Ensure there is a number of opportunity training events planned, resourced, and rehearsed prior to field training exercises and/or deployments. Typically, there is some "down time" for the medical platoon and the field surgeon, PA, and NCOs. This time can be better used if they are prepared. Potential training events can be executed with little notice when proper planning includes initiating an IV, assessing a patient, filling out a tactical combat casualty card, presenting a patient to the next higher level of provider, presenting a patient to the PA over an FM radio (and receiving instructions on providing care), and treating a combat stress reaction patient.

SECTION II – COMBAT LIFESAVER TRAINING

E-4. Each squad, crew, or equivalent-sized deployable unit will have at least one member certified as a CLS. Combat lifesavers must be recertified every 12 months at unit level according to AR 350-1.

ROLE OF THE COMBAT LIFESAVER

E-5. The role of a CLS is to treat the most common causes of death on the battlefield, which are massive hemorrhage and airway/respiratory problems. They are also given the skills to prevent complications and treat other associated but not immediately life-threatening injuries.

E-6. Immediate, far-forward medical care is essential on a widely dispersed and fluid battlefield to prevent Soldiers from dying of wounds. Medical platoon personnel may not be able to reach and apply lifesaving measures to all wounded Soldiers in a timely manner. The CLS is a nonmedical Soldier trained to provide lifesaving measures beyond the level of self-aid/buddy aid. A properly trained CLS is capable of stabilizing many types of casualties and can slow the deterioration of a wounded Soldier's condition until medical platoon personnel arrive. Functioning as a CLS is a secondary mission undertaken when the tactical situation permits.

E-7. Large-scale combat operations are characterized by a widely dispersed, rapidly moving battlefield. This presents constraints on the rapid acquisition of casualties and medical treatment. These constraints in many cases limit the ability of medical platoon personnel to provide immediate, far-forward medical treatment. The plan developed to provide care for Soldiers includes the CLS who has become an intricate part of providing care for the wounded Soldier.

E-8. A major advantage of the CLS is that they will probably be nearby if a member of their squad or crew is injured. It may take a combat medic several minutes or longer to reach the casualty, especially when the combat medic is treating seriously wounded members of the platoon. The CLS is trained to provide immediate care that can save a casualty's life, such as stopping severe bleeding and performing needle chest decompression for a casualty with tension pneumothorax. The CLS may also assist the combat medic in providing care and preparing casualties for evacuation when the CLS has no combat duties to perform.

E-9. The CLS is a bridge between the self-aid/buddy aid skills given to all Soldiers basic training and the medical training given to the combat medic or provider the tier 4 TCCC training if paramedic qualified (see DODI 1322.24).

TRAINING THE COMBAT LIFESAVER

E-10. Corps, divisions, and brigades, and battalions will implement CLS training within their commands and designate a staff surgeon responsible for supervising their CLS programs. The Army Combat LifeSaver Course information can be found on the All Partner Access Network's (APAN) CLS website.

E-11. In accordance with the individual critical task list (ICTL) Task: 081-68W-2003 instructors must meet the following qualifications:

- Ensure the course manager at the battalion is the TMT SQDLDR. Instructors are usually 68W sergeants and specialists.
- Verify all instructors are BLS certified.

- Verify an initial instructor evaluation was completed (by the Course Manager or Medical Director) NLT 30 days prior to the start of instruction.
- Ensure that all instructors are placed on additional duty orders.
- Ensure all instructors and assistant instructors (AI) are trained on equipment, course material, and requirements.

E-12. Units without qualifying medical platoon personnel will request training instructor support from the next higher command surgeon or local installation MTF.

E-13. Student and instructor materials for units and organizations are printed by the Army Training Support Center and shipped to the primary instructor. Unit training managers are not authorized to augment correspondence course material or change the length of the course. Training and testing will be conducted in accordance with the tasks, conditions, and standards established by TRADOC.

E-14. Proof of CLS course completion will be placed in the Soldier's military personnel folder in accordance with AR 600-8-104. Soldiers who successfully complete CLS in IMT will be issued certificates of training in accordance with this regulation and awarded course credit in the Army Training Requirements and Resources System (ATRRS).

E-15. Combat lifesaver training locations that already self-managing their training documentation in ATRRS in their local troop schools or other local ATRRS school code will continue to document their training completion roster utilizing local ATRRS clerks as before.

E-16. For those training locations that do not have an established ATRRS CLS under a local ATRRS school code, instructors will submit class completion rosters to MEDCoE Instructional Technology Support Services Help Desk.

Note. The Army CLS course does not limit the number of retests that can be administered to a student on a failed examination. However, the Soldier must be allowed at least one retest on each examination. The course manager may establish a maximum number of retests or procedures for approving more than one retest per examination.

EQUIPMENT AND SUPPLIES

E-17. Unit personnel are not authorized to increase or delete items contained in the CLS aid bag. All Class VIII supplies and materials required for CLS training will be requisitioned through normal supply channels.

E-18. Arrange for equipment and supplies as early as possible. The purchase of some items, such as IV infusion trainers and rescue breathing mannequins, may be required. The local Training and Audiovisual Support Center may have these items available. Training items will not be provided by MEDCoE.

ENROLLMENT

E-19. Enrollment request should be sent a minimum of four weeks prior to beginning of the course according to instructions found located on the APAN CLS website. To order books the medical platoon must complete the following:

- Submit a DA Form 1687 per the instruction on the APAN CLS website. The DA Form 1687 must include the following:
 - The “Location” block must show a valid, unit shipping address.
 - The Unit Identification Code.
 - The remarks section must show the unit representative’s, Army knowledge online user name and official email address.
- When the request is approved, the unit representative will receive instructions for ordering manuals through an online system.

FACILITIES

E-20. Facilities must be reserved well in advance. The facilities chosen should allow clear observation of demonstrations and provide room for student practice. Handwashing devices are required.

COURSE MATERIAL

E-21. Combat Lifesaver Course instructors are provided lesson plans, student self-study materials, written (multiple-choice) examinations, solutions to written examinations, and performance checklists. Training, testing, and grading are conducted under the supervision of qualified instructors at the Soldiers' home stations.

E-22. The CLS course is a 40 hour course consisting of self-study materials, classroom instruction, testing materials. The course consists of three subcourses:

- IS0873 (Combat Lifesaver Course: Instructor Guide) Edition “C”.
- IS0871 (Combat Lifesaver Course: Student Self-Study) Edition “C”.
- IS0875 (Combat Lifesaver Course: Examinations) Edition “C”.

E-23. Combat lifesaver presentations are located on the APAN CLS website.

E-24. Testing includes both proctored multiple-choice and performance examinations. Only one examination response (IS0875) is returned for grading upon completion of IS0871.

E-25. This is a GO or NO-GO course.

RECERTIFICATION

E-26. CLS tasks are perishable skills. Combat lifesavers must be recertified every 12 months on the performance-tested tasks in the CLS course. The printed material in the correspondence course can be locally reproduced and used for sustainment training.

E-27. Do not reenroll Soldiers requiring recertification. Unit instructors can accomplish this. The instructor’s guide also includes a test appropriate for recertification. It is the

responsibility of the personnel staff, not the medical platoon leader, to ensure that personnel records are updated following completion of CLS training.

PROGRAM MANAGERS

E-28. Program managers are not authorized to augment correspondence course material, change the length of the course, or increase or delete items contained in the CLS aid bag.

SUSTAINMENT TRAINING

E-29. To the extent needed to sustain skill proficiency, CLS will be exercised during home station training activities (to include field-training exercises) and during deployment for training (to include rotations through combat training centers).

COMBAT LIFESAVER AID BAG

E-30. The CLS carries a small aid bag (called an MES) containing supplies for controlling bleeding, relieving tension pneumothorax, and performing other procedures. For a current listing of the supplies found in the aid bag, check the MMIP website. The website is managed USAMMA. The aid bags will be issued to the CLS only upon deployment (training and actual).

E-31. It is the responsibility of each CLS to ensure that—

- Their aid bag is stocked according to the prescribed packing list.
- All stocked items are serviceable.
- Items have not exceeded their expiration dates.

CLASS VIII RESUPPLY OF COMBAT LIFESAVER AID BAG

E-32. In a deployed environment, resupply is accomplished in the same manner as during home station operations:

- Units with assigned medical platoon personnel will request Class VIII resupply for CLS aid bags through the BSMC's BMSO.
- Brigade units without assigned medical platoon personnel request Class VIII support through the BSMC's BMSO.
- Emergency resupply is provided to all units by the nearest medical unit capable of doing so.

E-33. Medical platoons maintain stocks of medical material to resupply CLS aid bags during operations.

SECTION III – UNIT FIELD SANITATION TEAM TRAINING

E-34. Historically, in every conflict up through World War II in which the United States was involved, approximately 20 percent of hospital admissions were the result of combat

injuries. The other 80 percent were the result of DNBI. In some areas the incidence of disease was so severe that entire divisions became combat ineffective.

E-35. The problem was so severe that the United States War Department ordered the establishment of antimalaria details within every company, battery, or similar sized unit. Once established and trained, antimalaria details were very successful in reducing the incidence of arthropodborne disease. As a result of their success the antimalaria details were redesignated as unit field sanitation teams, and their duties and responsibilities were significantly increased.

Note. A DNBI casualty is defined as a Soldier who is lost to an organization by reason of disease or injury and who is not a battle casualty.

CONTEMPORARY OPERATIONS

E-36. Operating Forces are frequently required to maneuver in some of the harshest environments on earth. Many of these areas present significant health threats which can quickly result in the spread of disease and increased incidences of nonbattle related injuries if not properly addressed. Disease and nonbattle injury rates from 1991 to 2003 are depicted in table E-1.

Table E-1. Disease and nonbattle injury rates in contemporary operations

<i>Percentage of casualties attributed to disease and nonbattle injury</i>	
Operation Desert Shield/Desert Storm, 1991	6.5 percent
Operation Joint Endeavor, 1995	7.1 percent
Operation Joint Guardian, 1999	8.1 percent
Operation Enduring Freedom, 2001	5 percent

IMPORTANCE OF THE UNIT FIELD SANITATION TEAMS

E-37. The drop in DNBI rates as reflected in table E-1 on page E-6 is due largely to the efforts of well-trained, appropriately equipped, and command supported unit field sanitation team members. Unit field sanitation team members are extremely effective in assisting the commander's efforts to prevent DNBI related losses to the unit.

E-38. Countering health threats that Soldiers are confronted with is as simple as implementing and enforcing unit-level field hygiene and sanitation practices and monitoring individual personnel protective measures. These are the reasons for which the unit field sanitation team was created and which continue to make it the most effective tool that commanders have at their disposal to ensure that their Soldiers remain healthy and fit to accomplish the mission.

E-39. It is critical that commanders—

- Provide command emphasis regarding the importance of field hygiene and sanitation and personal protective measures.

- Set the example of the importance of the program for their Soldiers.
- Enforce the standards set for the use of personal protective measures.
- Select only the very best Soldiers to staff the field sanitation teams.
- Ensure that their teams are well trained and equipped to perform their duties.

ESTABLISHING UNIT FIELD SANITATION TEAMS

E-40. Establishing and employing unit field sanitation teams is covered in AR 40-5, AR 350-1, and DA Pam 40-11. Commanders of all company-sized units should establish, train, equip, and deploy unit field sanitation teams when required. For more information on Unit Field Sanitation Teams, refer to ATP 4-25.12.

MISSION

E-41. The mission of the unit field sanitation team is to assist commanders in maintaining the health and the well-being of the Soldiers assigned to the unit. They accomplish this by—

- Performing arthropod and rodent management control measures within the unit area.
- Supervising the disinfection of unit bulk water supplies and monitoring residual chlorine levels.
- Teaching Soldiers—
 - Individual water purification techniques.
 - The dangers of consuming food and drinks from unapproved sources.
- Inspecting unit-level food service personnel, feeding facilities, and food service equipment.
- Supervising the placement, construction, and maintenance of—
 - Unit-level garbage disposal facilities and soakage pits.
 - Field latrines and urinals and then conducting regular sanitation inspections.
 - Hand washing stations at latrines and feeding areas and replenishment of supplies such as water, soap, paper towels, or alcohol based hand sanitizer.

Note. Unit details, not the field sanitation team members, are responsible for constructing and maintaining field waste disposal facilities.

- Providing—
 - Training, guidance, and inspections of personnel hygiene practices to establish and maintain high levels of personal hygiene.
 - Information and assistance relating to individual personal protective measures to include use of the DOD Insect Repellent System.

- Assisting in the selection of unit field sites and reporting the presence and location of suspected toxic industrial materials as necessary.
- Identifying and posting noise hazards in the unit area. Providing the unit commander a list of potential hazards within the unit area.
- Reporting findings of inspections to the unit commander.

E-42. Soldiers selected for unit field sanitation teams must have the confidence and support of the commander and be given sufficient time to perform their duties adequately.

ORGANIZATION

E-43. The unit field sanitation teams consist of one NCO and one enlisted Soldier. In units with organic medical platoon personnel, the NCO should be a medical NCO. Soldiers appointed to field sanitation teams should have at least six months of service remaining with the unit after completion of certification training.

ASSIGNMENT

E-44. Unit field sanitation teams are established within company-sized units.

DEPENDENCIES

E-45. Unit field sanitation teams are dependent on support from preventive medicine personnel at brigade and EAB for—

- Field sanitation team certification training.
- Field screening and presumptive analysis of water supplies.
- Basic pest management and surveillance.
- Limited application of pesticides.
- Limited medical surveillance.

EMPLOYMENT

E-46. Unit field sanitation teams are employed within company-sized units while deployed or when operating in the field for extended periods of time.

FIELD SANITATION TEAM TRAINING

E-47. Field sanitation team training should be conducted under field conditions. The certification course consists of 40 hours of—

- Classroom instruction.
- Demonstrations on the proper use and maintenance of field sanitation team equipment (field sanitation kit, National Stock Number 4540-01-578-4352).
- Practical exercises designed to test the Soldiers' competence.

E-48. At the end of the training program, Soldiers are administered an examination which consists of 50 questions. After the successful completion of the training program and the examination, Soldiers are awarded field sanitation team certification.

E-49. Field sanitation team certification training must be conducted when—

- Commanders appoint Soldiers to perform as members of unit field sanitation teams.
- Members of the unit field sanitation teams require sustainment training.
- Units are scheduled to operate in the field for extended periods of time or when deploying.

Note. Establishing and training additional field sanitation teams can be beneficial in situations where commanders are responsible for establishing a presence in multiple locations. This is especially true in situations where the terrain, distance between locations, and tactical situation make it difficult for two teams to adequately support the Soldiers at those locations.

E-50. Unit field sanitation team course standards and training support packages are established and maintained by the Director, Distributed Learning Division, MCCS-HC-DL, United States Army MEDCoE.

SECTION IV – CHEMICAL, BIOLOGICAL, RADIOLOGICAL, AND NUCLEAR MEDICAL TRAINING

E-51. Medical platoon personnel will provide a health threat briefing to deploying personnel identifying health threats and countermeasures to include applicable immunizations and other pre-exposure drugs, such as pyridostigmine bromide.

PREDEPLOYMENT TRAINING

E-52. All deploying personnel should be trained in CBRN-related self-aid/buddy aid, and CLS skills to include immediate decontamination, administration of CBRN medical countermeasures and barrier creams, and the wear/care and inspection of IPE or personal protective equipment.

E-53. The IPE is the personal clothing and equipment provided to all military personnel to protect them from CBRN hazards. Protective equipment that meets civilian certifications as required by the United States Department of Labor Occupational Safety and Health Administration is considered PPE.

E-54. A best practice is for all medical platoon personnel and selected nonmedical augmentees be trained in CBRN casualty triage, TCCC in a CBRN environment, and how to thoroughly decontaminate CBRN-contaminated casualties. Topics for training include:

- Roles of medical platoon personnel.
- Roles of nonmedical augmentees.
- Patient decontamination principles.

- Zones of contamination.
- Safety, heat injury prevention, and water consumption.
- Employment of the BAS CBPS system.
- Establishment and operation of a battalion-level PDS.
- Core components of the PDS and patient flow.
- Patient decontamination site operational considerations.
- Procedures for closing down a PDS.

PRE-ATTACK POSTURE

E-55. Given the disruption of transportation, communications, and operations during and following a CBRN attack, it should be clear that preparation is the key to survival and effectively providing HSS. Preparing a simple and complete tactical TACSOP and HSS plan that integrates CBRN is the first step. Critical training for medical platoon personnel before a CBRN attack includes how to—

- Survive the attack individually and as a unit.
- Operate the Role 1 BAS in a CBRN environment.
- Effectively care for CBRN patients.

ESTABLISH A SECURITY PERIMETER AROUND THE PATIENT DECONTAMINATION SITE

E-56. When not setting up the decontamination site, nonmedical augmentees can receive additional just-in-time training on such topics as: basic medical signs and symptoms of chemical agents; safe patient litter transfer techniques; roles and responsibilities; the use of detection devices; the importance of work rest cycles; and prevention of heat injuries.

SECTION V – ADDITIONAL TRAINING REQUIREMENTS

E-57. Detailed below are a list of training tasks. Table E-2 outlines specific medical training for medical platoon personnel while table E-3 on page E-12 depicts battalion-level medical training of nonmedical personnel.

Table E-2. Additional battalion medical personnel training

Medical Personnel Training
Continuing medical education and clinical training of subordinate medical platoon personnel.
Providing training to battalion medical platoon personnel in tactical combat casualty care principles and procedures. To include the tenants of holistic health and fitness in accordance with FM 7-22.
Providing training for tables 1-7 and support for the table 8 biannual recertification of the military occupational specialty 68W battalion medical platoon personnel in accordance with training circular 8-800.
Medical battle drill training and/or rehearsals. Including: <ol style="list-style-type: none"> 1. Establish the battalion aid station. 2. Conduct extended medical support operations. 3. Relocate the battalion aid station. 4. Establish and rehearse a casualty collection point include triage. 5. Evacuate patients. 6. Establish patient decontamination site.
Training to recognized, treat, and document suspected or known chemical, biological, radiological, and nuclear (CBRN) contaminated patients.
Training to operate (triage, decontamination, treatment, and transport) in mission-orientated protective posture level 4.
Training to establish and manage a temporary morgue in a noncontaminated area and CBRN contaminated area.
See table 5-13, Additional proficiency skills for medical personal for a list of recommended CBRN courses for medical platoon personnel.
Planning, executing, and maintaining the training of medical platoon personnel for battalion patient decontamination site operations. This includes: <ol style="list-style-type: none"> 1. Roles of medical platoon personnel. 2. Roles of nonmedical augmentees. 3. Patient decontamination principles. 4. Zones of contamination. 5. Safety, heat injury prevention, and water consumption. 6. Employment of the battalion aid station chemical biological protective shelter system. 7. Establishment and operation of a battalion-level patient contamination site. 8. Core components of the patient contamination site and patient flow. 9. Patient decontamination site operational considerations. 10. Procedures for closing down a patient contamination site.
Medical records training per AR 40-400 and AR 40-66.

Table E-3. Additional battalion nonmedical personnel training

<i>Battalion-level nonmedical personnel training</i>
Planning, executing, and maintaining the training of the battalion combat lifesaver program.
Planning, executing, and maintaining the training of battalion field sanitation teams.
See table 5-13, Additional proficiency skills for medical personal for a list of recommended chemical, biological, radiological, and nuclear courses for nonmedical personnel.
<p>Planning, executing, and maintaining the training of nonmedical augmentees for battalion patient decontamination site operations. This includes:</p> <ol style="list-style-type: none"> 1. Roles of medical platoon personnel. 2. Roles of nonmedical augmentees. 3. Patient decontamination principles. 4. Zones of contamination. 5. Safety, heat injury prevention, and water consumption. 6. Employment of the battalion aid station chemical biological protective shelter system. 7. Establishment and operation of a battalion-level patient decontamination site. 8. Core components of the patient decontamination site and patient flow. 9. Patient contamination site operational considerations. 10. Procedures for closing down a patient decontamination site.
<p>Planning, executing, and maintaining the training of battalion nonmedical augmentees as aid and litter teams. This includes:</p> <ol style="list-style-type: none"> 1. Litter carries. 2. Manual carries. 3. Load and unload unit vehicles for casualty evacuation (CASEVAC). 4. Load and unload unit medical evacuation (MEDEVAC) vehicles. 5. Transmit a 9-line medical evacuation request. 6. Unit tactical standard operating procedures for CASEVAC vehicle marking, notification techniques. 7. Traversing rough terrain with a litter. 8. Organization and layout of the casualty collection point layout. 9. Triage categories.
Supervising all unit-level tactical combat casualty care training (also part of warrior tasks).
Planning and oversight of operational public health training for battalion personnel (to include personal hygiene).
Planning and oversight of holistic health and fitness training for the battalion in accordance with FM 7-22.
Providing Soldier and leader training on the prevention of negative combat and operational stress reaction and other stress-related reactions.

Appendix F

Battalion-Level Symbolology

This appendix depicts and describes the unit symbols that will be of use as medical platoon leaders and PSGs. Refer to MIL-STD 2525D and FM 1-02.2 for more information about military symbols.

F-1. Military symbols are governed by the rules in MIL-STD 2525D. Field Manual 1-02.2 is the Army proponent publication for all military symbols and complies with MIL-STD 2525D.

F-2. Field Manual 1-02.2 provides a single standard for developing and depicting hand drawn and computer-generated military symbols for situation maps, overlays, and annotated aerial photographs for all types of military operations. A military symbol is a graphic representation of a unit, equipment, installation, activity, control measure, or tactical task relevant to military operations that is used for planning or to represent the common operational graphic on a map, display, or overlay. Table F-1 through F-4 (below through page F-12) contains examples of select symbols used at the battalion-level.

Table F-1. Battalion-level echelons





<i>Unit</i>	<i>Unit symbol</i>	<i>Example</i>
<p>Team or crew Note. This is the smallest echelon and should not be confused with company team and brigade combat team.</p>		<p style="text-align: center;">∅</p> 
<p>Squad - A small military unit typically containing two or more fire teams. (ADP 3-90)</p>		
<p>Section - A tactical unit of the Army and Marine Corps smaller than a platoon and larger than a squad. (ADP 3-90)</p>		

Table F-1. Battalion-level echelons (continued)





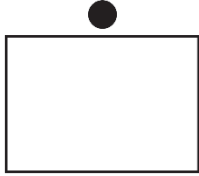

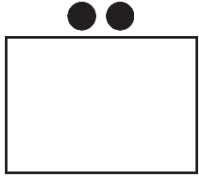

<i>Unit</i>	<i>Unit Symbol</i>	<i>Example</i>
<p>Platoon - A subdivision of a company or troop consisting of two or more squads or sections. (ADP 3-90)</p> <p>Detachment - A tactical element organized on either a temporary or permanent basis for special duties. (ADP 3-90)</p>		
<p>Company - unit consisting of two or more platoons, usually of the same type, with a headquarters and a limited capacity for self-support. (ADP 3-90)</p> <p>Battery - A company-size unit in a field artillery or air defense artillery battalion. (ADP 3-90)</p> <p>Troop - A company-size unit in a cavalry organization. (ADP 3-90)</p>		
<p>Battalion - A unit consisting of two or more company-, battery-, or troop-size units and a headquarters. (ADP 3-90)</p> <p>Squadron - A battalion size unit in a cavalry organization. (see ATP 3-20.96)</p>		
<p>Regiment or group - A unit consisting of 2 or more battalions. (ADP 3-90)</p>		
<p>Brigade - A unit consisting of two or more battalions and a headquarters company or detachment. (ADP 3-90)</p>		

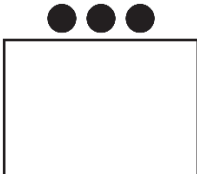
Table F-2. Battalion-level unit symbols

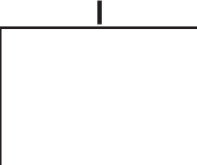

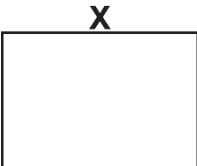

<i>Unit</i>	<i>Unit Symbol</i>	<i>Example</i>
Combat trains command post - controls and coordinates administrative and logistical support. (See ATP 6-0.5 for more information on combat trains.)	CTCP	 CTCP
Early-entry command post - A lead element of a headquarters designed to control operations until the remaining portions of the headquarters are deployed and operational. (FM 6-0)	EECP	 EECP
Field trains command post - A facility containing a personnel administration center, elements of the logistics staff (battalion or brigade logistics staff officer) sustainment staff section, elements of company supply sections, and elements of the forward support company. (See ATP 6-0.5 for more information on field trains.)	FTCP	 FTCP
Main command post - A facility containing the majority of the staff designed to control current operations, conduct detailed analysis, and plan future operations. (FM 6-0)	MAIN	 MAIN
Tactical command post - A facility containing a tailored portion of a unit headquarters designed to control portions of an operation for a limited time. (FM 6-0)	TAC	 TAC
Armor (tracked) - Provides main battle tank weapons system with 120mm smoothbore cannon and increased armor protection. (See FM 3-20.21 for more information on armor.)		 Tank company

Table F-2. Battalion-level unit symbols (continued)



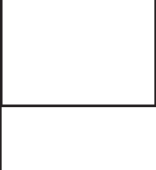
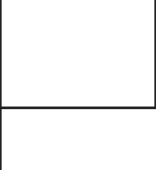

<i>Unit</i>	<i>Unit Symbol</i>	<i>Example</i>
<p>Armored (tracked) cavalry - Conducts reconnaissance and security with armored tracked fighting vehicles to support the brigade's awareness and knowledge in the area of operations. (See ATP 3-20.96 for more information on cavalry.)</p>		<p>I</p>  <p>Armored cavalry troop</p>
<p>Combined arms - Combines the efforts of armor units and mechanized infantry units to execute tactical missions as part of a combined arms operation. (See FM 3-96 for more information on combined arms.)</p>		<p>II</p>  <p>Combined arms battalion</p>
<p>Cavalry (reconnaissance) - Conducts reconnaissance and security to support the brigade's awareness and knowledge in the area of operations. (See FM 3-98 and ATP 3-20.96 for more information on cavalry reconnaissance.)</p>		<p>II</p>  <p>Cavalry (reconnaissance) battalion</p>
<p>Field artillery - Equipment, supplies, ammunition, and personnel involved in the use of cannon, rocket, or surface-to-surface missile launchers. (JP 3-09)</p>		<p>II</p>  <p>Field artillery battalion</p>
<p>Infantry - Provides Soldiers trained, armed, and equipped to fight dismounted by means of fire and movement in order to destroy, defeat, capture, or repel an enemy assault. (See ATP 3-21.20 for more information on infantry.)</p>		<p>II</p>  <p>Infantry battalion</p>

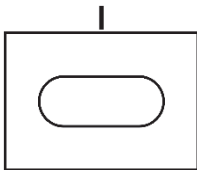
Table F-2. Battalion-level unit symbols (continued)

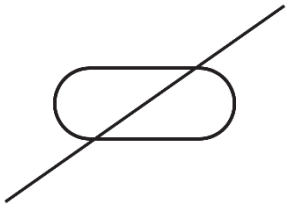
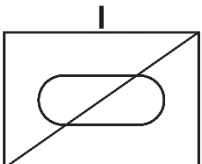

<i>Unit</i>	<i>Unit Symbol</i>	<i>Example</i>
<p>Mechanized armored (tracked) infantry - Provides armored tracked fighting vehicles to transport and support Soldiers trained, armed, and equipped to fight dismounted by means of fire and movement. (See FM 3-96 for more information on mechanized infantry.)</p>		 <p>Mechanized armored Infantry company</p>
<p>Stryker - Provides wheeled fighting vehicle transport and support Soldiers trained, armed, and equipped to fight dismounted by means of fire and movement. (See ATP 3-21.21 for more information on the Stryker battalion.)</p>		 <p>Stryker battalion</p>
<p>Infantry with mobile gun system - A Stryker brigade combat team asset that provides precise long range direct fire in support of infantry and cavalry units. (See ATP 3-21.21 and ATP 3-21.91 for more information.)</p>		 <p>Infantry Platoon with Mobile Gun System armored high mobility vehicle capability.</p>
<p>Mortar - Organic fire support to battalions, squadrons, companies, and troops, and are available to a commander when other indirect fire support is not available. (See ATP 3-21.90 for more information on mortars.)</p>		 <p>Mortar section</p>
<p>Medical - Promotes, improves, conserves, or restores the behavioral and physical well-being of personnel in the Army, and as directed in other Services, agencies, and organizations. (See FM 4-02 for more information on medical.)</p>		 <p>Medical unit with a COSC capability</p>

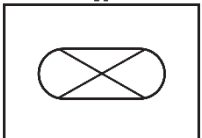
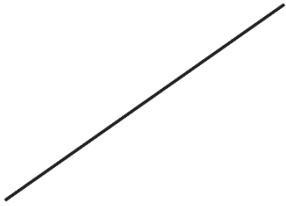
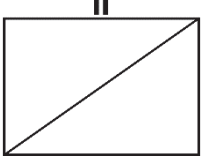
Table F-2. Battalion-level unit symbols (continued)

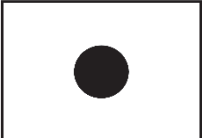
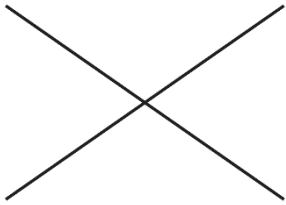
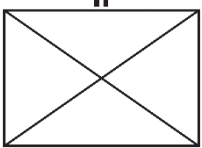

<i>Unit</i>	<i>Unit Symbol</i>	<i>Example</i>
<p>Medical treatment facility - Any facility established for the purpose of providing medical treatment. This includes the Role 1 battalion aid station, Role 2 BSMC, dispensaries, clinics, and Role 3 MTF. (FM 4-02)</p>		 <p>Medical treatment facility with a Role 1 capability</p>
<p>Support - The action of a force that aids, protects, complements, or sustains another force in accordance with the directive requiring such action. An element of a command that assists, protects, or supplies other forces in combat. (JP 1)</p>	<p>SPT</p>	 <p>Forward support company</p>
<p>Armored (protection) - A vehicle hull equipped or protected with armor.</p> <p>Note. As a sector 1 modifier, this symbol represents armored protected vehicles. To complete the vehicle type capability it requires a sector 2 mobility modifier. Table 2-7 (of FM 1-02.2 provides sector 2 mobility modifier.</p>		 <p>Infantry with armor high mobility wheeled vehicle capability</p>
<p>Brigade (echelon of support) - Provides support to a brigade.</p>	<p>X</p>	 <p>Brigade support battalion</p>
		 <p>Brigade engineer battalion</p>

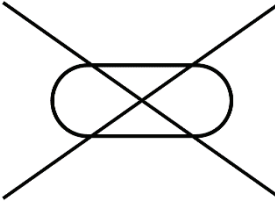
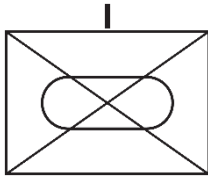
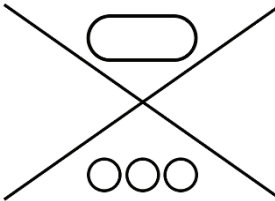
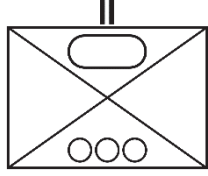
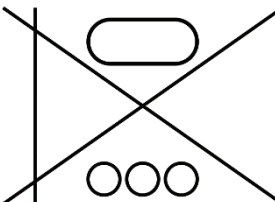
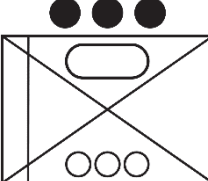
Table F-2. Battalion-level unit symbols (continued)

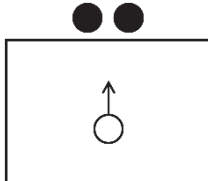
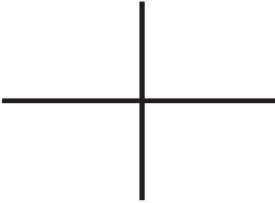
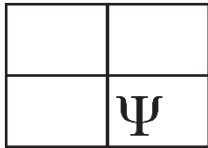

<i>Unit</i>	<i>Unit Symbol</i>	<i>Example</i>
<p>Medical evacuation - The timely and effective movement of the wounded, injured, or ill to and between medical treatment facilities on dedicated and properly marked ground and air medical platforms with en route care provided by medical personnel. Also called MEDEVAC. (ATP 4-02.2)</p>		<div style="border: 1px solid black; padding: 5px; margin-bottom: 5px;">  <p>Aviation unit aeromedical evacuation capability</p> </div> <div style="border: 1px solid black; padding: 5px;">  <p>Medical unit with wheeled high mobility vehicle ground evacuation capability</p> </div>
<p>Medical Role 1 - Unit-level medical care capability provided by the combat medic or medical treatment provided by the battalion aid station. (see FM 4-02)</p>	<p style="font-size: 2em; font-weight: bold;">1</p>	<div style="border: 1px solid black; padding: 5px;">  <p>Role 1 platoon-sized BAS with airborne capability</p> </div>
<p>Medical Role 2 - Capability to provide care by area support squads or medical treatment platoons of medical companies with greater medical capabilities available than Role 1. (see FM 4-02)</p>	<p style="font-size: 2em; font-weight: bold;">2</p>	<div style="border: 1px solid black; padding: 5px;">  <p>Role 2 company-sized BSMC with armored tracked capability</p> </div>
<p>Medical Role 3 - Capability to provide care to all categories of patients to include resuscitation, initial wound surgery, damage control surgery, and postoperative treatment. (see FM 4-02)</p>	<p style="font-size: 2em; font-weight: bold;">3</p>	<div style="border: 1px solid black; padding: 5px;">  <p>Hospital center with Role 3 capability</p> </div>

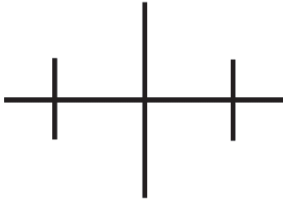
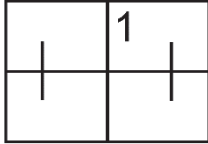
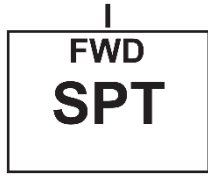
Table F-2. Battalion-level unit symbols (continued)

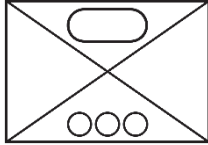
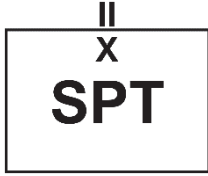
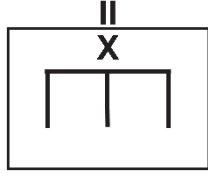



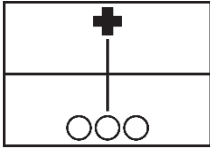
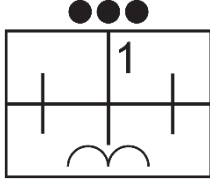
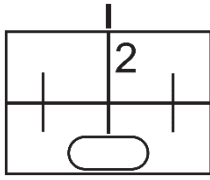
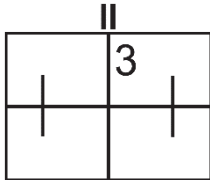

<i>Unit</i>	<i>Unit Symbol</i>	<i>Example</i>
<p>Airborne - Capability to parachute into an objective area. (see JP 3-18, FM 3-99)</p>		 <p>BAS with Role 1 capability</p>
<p>Armored tracked - A vehicle equipped or protected with armor and with a continuous band of treads or track plates for self-propelled mobility. Note. As a sector 2 modifier, this symbol represents armored self-propelled tracked vehicle capability.</p>		 <p>Artillery unit with armored self-propelled (tracked) capability</p>
<p>Combat and Operational Stress Control (COSC) - A capability that provides behavioral health services such as consultation and combat and operational stress control. (see FM 4-02)</p>		 <p>Medical unit with COSC capability</p>
<p>Medical bed - A capability to identify and locate available adequate bed assets for current and anticipated needs. (see FM 4-02, ATP 4-02.5, ATP 4-02.55)</p>		 <p>Medical unit with Role 2, and 20 medical bed capability</p>

Table F-2. Battalion-level unit symbols (continued)

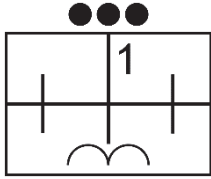

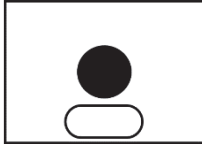

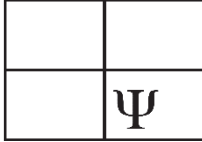

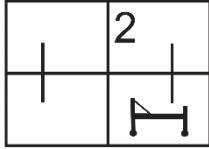
<i>Unit</i>	<i>Unit Symbol</i>	<i>Example</i>
<p>Preventive medicine - Capability that provides consultation and conducts medical surveillance which includes health risk communication, education, field sanitation, pest and vector control, disease risk assessment, environmental and occupational monitoring and health surveillance, personal protective measures, health threat controls for waste (human, hazardous, and medical) disposal, food safety inspection, and potable water surveillance. (see FM 4-02)</p>		 <p>Medical unit with preventive medicine capability</p>
<p>Surgical - Capability to provide life or limb saving operative treatment using specialized instruments to repair or stabilize a patient. (see FM 4-02)</p>		 <p>Medical unit with surgical capability</p>
<p>Veterinary services - A capability that provides consultation, animal care, food protection, and veterinary public health services. (see FM 4-02)</p>	<p style="text-align: center;">V</p>	 <p>Medical unit with veterinary service capability</p>
<p>Dental services - Capability to provide consultation, early treatment of severe oral and maxillofacial injuries; and augment medical personnel (as necessary) during mass casualty operations. (See FM 4-02)</p>		 <p>Medical unit with dental service capability</p>

Table F-2. Battalion-level unit symbols (continued)

<i>Unit</i>	<i>Unit Symbol</i>	<i>Example</i>
<p>Wheeled (high mobility) - A wheeled capability that can traverse various types of off-road terrain, unimproved routes, and paved road networks</p>		 <p>Reconnaissance unit with armored wheeled (high mobility) vehicle capability</p>

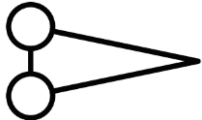
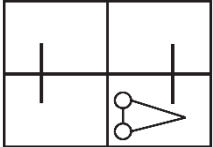
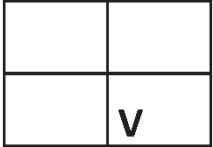
Note. To avoid overlapping main icon with modifiers:

1. Some modifiers are offset to the right by design to avoid overlapping with the main icon.
2. When modifiers cannot offset to the right, shorten the vertical center line to allow space for the modifier.

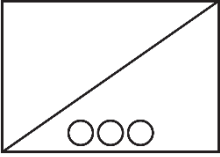
Table F-3. Medical control points



<i>Unit</i>	<i>Unit Symbol</i>	<i>Example</i>
<p>Ambulance exchange point - A location where a patient is transferred from one ambulance to another en route to a medical treatment facility. Also called AXP. (ATP 4-02.2)</p>	<p>AXP</p>	<p>160300ZDEC44 162359ZDEC44</p>  <p>C/426/1BCT 101AAD</p>
<p>Ambulance control point - A manned traffic regulating, often stationed at a crossroad or road junction, where ambulances are directed to one of two or more directions to reach loading points and medical treatment facilities. (ATP 4-02.2)</p>	<p>ACP</p>	<p>151000ZJAN19- 152359ZJAN19</p>  <p>514CO/56BN 62MEDBDE(SPT)</p>
<p>Ambulance load point - This is the point in the shuttle system where one or more ambulances are stationed ready to receive patients for evacuation. (ATP 4-02.2)</p>	<p>ALP</p>	<p>171800ZSEP44- 172359ZSEP44</p>  <p>690CO/261BN 44MEDBDE(SPT)</p>

Table F-3. Medical control points (continued)





<i>Unit</i>	<i>Unit Symbol</i>	<i>Example</i>				
<p>Ambulance relay point - A point in the shuttle system where one or more empty ambulances are stationed to advance to a loading point or to the next relay post to replace departed ambulances. (ATP 4-02.2)</p>	<p>ARP</p>	<p>251400ZAPR20- 252300ZAPR20</p> <div style="display: flex; align-items: center; justify-content: center;"> <div style="border: 1px solid black; padding: 5px; text-align: center; margin-right: 10px;"> <p>ARP</p> <p>1</p> </div> <div style="margin-left: 10px;"> <p>568CO/168BN 65MEDBDE(SPT)</p> </div> </div>				
<p>Casualty collection point - A location that may or may not be staffed, where casualties are assembled for evacuation to a medical treatment facility. (ATP 4-02.2)</p>	<p>CCP</p>	<p>060104ZJUN44- 062359ZJUN44</p> <div style="display: flex; align-items: center; justify-content: center;"> <div style="border: 1px solid black; padding: 5px; text-align: center; margin-right: 10px;"> <p>CCP</p> <p>2/327</p> </div> <div style="margin-left: 10px;"> <p>1BCT 101AAD</p> </div> </div>				
<p>United States and NATO Class VIII - (medical)</p>		<p>050001ZJUN19- 052359ZJUN19</p> <div style="display: flex; align-items: center; justify-content: center;"> <div style="border: 1px solid black; padding: 5px; text-align: center; margin-right: 10px;"> <table border="1" style="width: 100%; height: 100%;"> <tr> <td style="width: 50%; height: 50%;"></td> <td style="width: 50%; height: 50%;"></td> </tr> <tr> <td style="width: 50%; height: 50%;"></td> <td style="width: 50%; height: 50%;"></td> </tr> </table> <p>C/82</p> </div> <div style="margin-left: 10px;"> <p>82BSB/ 3BCT/82ABD</p> </div> </div>				

Table F-4. Vehicle symbols

<i>Function</i>	<i>Modifier</i>	<i>Modifier icon usage construct example and symbol translation</i>
Medical Evacuation		 <p>Medical evacuation aircraft rotary wing</p>
		 <p>Medical evacuation aircraft fixed wing</p>
		 <p>Medical evacuation wheeled high mobility vehicle</p>
		 <p>Medical evacuation armored tracked vehicle</p>
		 <p>Medical evacuation armored wheeled high mobility vehicle</p>
		 <p>Hospital Ship</p>

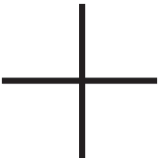
Appendix G

Law of Land Warfare and Medical Ethics

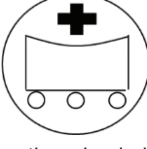
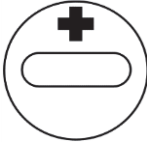
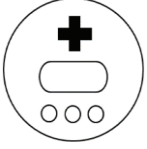
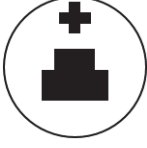
The conduct of armed hostilities on land is regulated by both written and unwritten law. This land warfare law is derived from numerous conventions and treaties. Collectively, these treaties are often referred to as The Hague and Geneva Conventions. Whereas the Hague Conventions concern the methods and means of warfare, the Geneva Conventions concern the victims of war or armed conflict. The Geneva Conventions are four separate international treaties, signed in 1949. The Conventions are very detailed and contain many provisions, which are tied directly to the medical mission. These Conventions are entitled:

- Geneva Convention for the Amelioration of the Condition of the Wounded and Sick in Armed Forces in the Field (GWS).
- Geneva Convention for the Amelioration of the Condition of the Wounded, Sick and Shipwrecked Members of the Armed Forces at Sea.
- Geneva Convention Relative to the Treatment of Prisoners of War (GPW).
- Geneva Convention Relative to the Protection of Civilian Persons in Time of War (GC).

This appendix discusses areas of emphasis that pertain to the medical platoon and its execution of the AHS support mission for the maneuver battalion.

SECTION I – THE LAW OF LAND WARFARE

G-1. The conduct of armed hostilities on land is regulated by the law of land warfare. This body of law is inspired by the desire to diminish the evils of war by—

- Protecting both combatants and noncombatants from unnecessary suffering.
- Safeguarding certain fundamental human rights of persons who fall into the hands of the enemy, particularly detainees, the wounded and sick, and civilians.
- Facilitating the restoration of peace.

G-2. The law of land warfare places limits on the exercise of a belligerent's power in the interest of furthering that desire (diminishing the evils of war), and it requires that belligerents—

- Refrain from employing any kind or degree of violence which is not actually necessary for military purposes.
- Conduct hostilities with regard for the principles of humanity and chivalry.

G-3. Refer to DODD 2311.01E and FM 6-27/MCTP 11-10C (*The Commander's Handbook on the Law of Land Warfare*) for additional information on the law of land warfare.

PROTECTION AND IDENTIFICATION OF MEDICAL PERSONNEL

G-4. Article 24 of the GWS provides special protection for “Medical personnel exclusively engaged in the search for, or the collection, transport or treatment of the wounded or sick, or in the prevention of disease, [and] staff exclusively engaged in the administration of medical units and establishments . . . [emphasis added].” Article 25 provides limited protection for “Members of the armed forces specially trained for employment, should the need arise, as hospital orderlies, nurses or auxiliary stretcher-bearers, in the search for or the collection, transport or treatment of the wounded and sick. If they are carrying out these duties at the time when they come into contact with the enemy or fall into his hands [emphasis added].”

PROTECTION

G-5. There are two separate and distinct forms of protection:

- The first is protection from intentional attack if medical personnel are identifiable as such by an enemy in a combat environment. Normally, this is facilitated by medical personnel wearing an armband bearing the distinctive emblem (a Red Cross or Red Crescent on a white background) or by their employment in a medical unit, establishment, or vehicle (including medical aircraft and hospital ships) that displays the distinctive emblem. Persons protected by Article 25 may wear an armband bearing a miniature distinctive emblem only while executing medical duties.
- The second protection provided by the GWS pertains to medical personnel who fall into the hands of the enemy. Article 24 personnel are entitled to “retained person” status. They are not deemed to be prisoner’s of war (POW) but otherwise benefit from the protections of the GPW. Article 28 of the GWS states they are authorized to carry out medical duties only and “. . . shall be retained only in so far as the state of health . . . and the number of POWs require.” Article 25 personnel are POWs, but shall be employed to perform medical duties in so far as the need arises. They may be required to perform other duties or labor, and they may be held until a general repatriation of POWs is accomplished upon the cessation of hostilities.

SPECIFIC CASES

G-6. Army Medicine personnel and non-Army Medicine personnel assigned to medical units fall into the category identified in Article 24 provided they meet the exclusively engaged criteria of that article. The United States Army does not have any personnel who officially fall into the category identified in Article 25. While it is not a violation of the GWS for Article 24 personnel to perform nonmedical duties, it should be understood, however, that Article 24 personnel lose their protected status under that article if they perform duties or tasks inconsistent with their noncombatant role. Should those personnel later take up their medical duties again, a reasonable argument might be made that they cannot regain Article 24 status since they have not been exclusively engaged in medical duties and that such switching of roles might at best cause such personnel to fall under the category identified in Article 25. Listed below are some of the main provisions of Articles 24 and 25:

- While only Article 25 refers to nurses, nurses are Article 24 personnel if they meet the criteria of that article.
- The AHS officers and NCOs assigned to nonmedical positions in a brigade support battalion are neither Article 24 nor Article 25 personnel. Such assignments place them in the role of a combatant. Examples of such personnel are:
 - The AHS officers serving as commanders of brigade support battalions with responsibility for base or base-cluster defense, as well as command and control of medical and nonmedical units.
 - The AHS officers and NCOs assigned to nonmedical staff positions with a BSB with responsibility for planning and supervising the sustainment support for a BCT or other combat unit.
- Article 24 personnel who might become Article 25 personnel by virtue of their switching roles could include the following:
 - A medical company commander, a physician, or the executive officer (a medical service corps officer) detailed as convoy march unit commander with responsibility for medical and nonmedical unit routes of march, convoy control, defense, and repulsing attacks.
 - Helicopter pilots, who are permanently assigned to a dedicated air ambulance unit, but fly helicopters not bearing the Red Cross emblem on standard combat missions during other times.
- The GWS does not itself prohibit the use of Article 24 personnel in perimeter defense of nonmedical units such as areas or base-clusters, under overall security defense plans, but the policy of the United States Army is that Article 24 personnel will not be used for this purpose. Adherence to this policy should avoid any issues regarding their status under the GWS due to a temporary change in their role from noncombatant to combatant. Medical personnel may guard their own unit without any concurrent loss of their protected status.

IDENTIFICATION CARDS AND ARMBANDS

G-7. Medical personnel who meet the exclusively engaged criteria of Article 24, GWS, are entitled to wear an armband bearing the distinctive emblem of the Red Cross and carry the medical personnel identification card authorized in Article 40, GWS (in the United States Armed Services, DD Form 1934 [*Geneva Conventions Identity Card for Medical and Religious Personnel Who Serve in or Accompany Armed Forces*]). Article 25 personnel and medical personnel serving in positions that do not meet the exclusively engaged criteria of Article 24 are not entitled to carry the medical personnel identification card or wear the distinctive emblem armband. Such personnel carry a DOD Common Access Card and under Article 25, may wear an armband bearing a miniature distinctive emblem when executing medical duties.

PROTECTION AND IDENTIFICATION OF MEDICAL UNITS, ESTABLISHMENTS, BUILDINGS, MATERIEL, AND MEDICAL TRANSPORTS

G-8. There are two separate and distinct forms of protection, protection from intentional attack and protection when falling into the hands of the enemy.

PROTECTION FROM INTENTIONAL ATTACK

G-9. The first is protection from intentional attack if medical units, establishments, or transports are identifiable as such by an enemy in a combat environment. Normally, this is facilitated by medical units or establishments flying a white flag with a Red Cross and by marking buildings and transport vehicles (aircraft or ground) with the distinctive emblem.

- It follows that if we cannot attack recognizable medical units, establishments, or transports, we should allow them to continue to give treatment to the wounded in their care as long as this is necessary.
- All vehicles employed exclusively on medical transport duty are protected in the operational area. Medical vehicles being used for both military and medical purposes, such as moving wounded personnel during an evacuation and carrying retreating belligerents, are not entitled to protection.
- The second paragraph of Article 19 imposes an obligation upon those responsible to “. . . ensure that the said medical establishments and units are, as far as possible, situated in such a manner that attacks against military objectives cannot imperil their safety.” Hospitals should be sited alone, as far as possible from military objectives. The unintentional bombardment of a medical establishment or unit due to its presence among or in proximity to valid military objectives is not a violation of the GWS. Legal protection is certainly valuable, but it is more valuable when accompanied by practical safeguards.

PROTECTION WHEN FALLING INTO THE HANDS OF THE ENEMY

G-10. The second protection provided by the GWS pertains to medical units, establishments, materiel, and transports that fall into the hands of the enemy.

- Captured mobile medical unit materiel is to be used first to treat the patients in the captured unit. If there are no patients in the captured unit, or when those who were there have been moved, the materiel is to be used for the treatment of other wounded and sick persons.
- Generally, the buildings, materiel, and stores of fixed medical establishments will continue to be used to treat wounded and sick, however, after provision is made to care for remaining patients, operational commanders may make other use of them. All distinctive markings must be removed if the buildings are to be used for other than medical purposes.
- The materiel and stores of fixed establishments and mobile medical units are not to be intentionally destroyed, even to prevent them from falling into enemy hands. In certain extreme cases, buildings may have to be destroyed for operational reasons.
- Medical transports that fall into enemy hands may be used for any purpose once arrangement has been made for the medical care of the wounded and sick they contain. The distinctive markings must be removed if they are to be used for nonmedical purposes.

IDENTIFICATION

G-11. The GWS contains several provisions regarding the use of the Red Cross emblem on medical units, establishments, and transports. (The identification of medical personnel has been previously discussed.)

- Article 39 of the GWS reads as follows: “Under the direction of the competent military authority, the emblem shall be displayed on the flags, armlets and on all equipment employed in the Medical Service.”
 - There is no obligation of a belligerent to mark his units with the emblem. Sometimes a commander (generally no lower than a brigade commander for NATO forces) may order the camouflage of his medical units in order to conceal the presence or real strength of his forces. The enemy must respect a medical unit if they know of its presence, even one that is camouflaged or not marked. The absence of a visible Red Cross emblem, however, coupled with a lack of knowledge on the part of the enemy as to the unit’s protected status, may render that unit’s protection valueless.
 - The distinctive emblem is not a Red Cross alone; it is a Red Cross on a white background. Should there be some good reason, however, why an object protected by the Convention can only be marked with a Red Cross without a white background, belligerents may not make the fact that it is so marked a pretext for refusing to respect it.
 - Some countries use the Red Crescent on a white background in place of the Red Cross. This emblem is recognized as an authorized exception under

Article 38, GWS. Additional Protocol III to the Geneva Conventions also recognizes the Red Crystal. The Red Crystal replaces the Red Star of David.

- The initial phrase of Article 39 shows that it is the military commander who controls the emblem and can give or withhold permission to use it. They are at all times responsible for the use made of the emblem and must see that it is not improperly used by the troops or by individuals.
- Article 42 of the GWS specifically addresses the marking of medical units and establishments:
 - “The distinctive flag of the Convention shall be hoisted only over such medical units and establishments as are entitled to be respected under the Convention, and only with the consent of the military authorities.” (Paragraph 1, Article 42, GWS.) Although the Convention does not define “the distinctive flag of the Convention,” what is meant is a white flag with a Red Cross in its center. Also, the word “flag” must be taken in its broadest sense. Hospitals are often marked by one or several Red Cross emblems painted on the roof. Finally, the military authority must consent to the use of the flag (see the above comments on Article 39) and must ensure that the flag is used only on buildings entitled to protection.
 - “In mobile units, as in fixed establishments, it [the distinctive flag] may be accompanied by the national flag of the Party to the conflict to which the unit or establishment belongs.” (Article 42, GWS.) This provision makes it optional to fly the national flag with the Red Cross flag. It should be noted that in an operational area the national flag is a symbol of belligerency and is therefore likely to provoke attack.
 - In a NATO conflict, NATO STANAG provides for camouflage of the Geneva emblem on medical facilities where the lack of camouflage might compromise operations. Medical facilities on land, supporting forces of other nations, will display or camouflage the Geneva emblem in accordance with national regulations and procedures. When failure to camouflage would endanger or compromise operational operations, the camouflage of medical facilities may be ordered by a NATO commander of at least brigade level or equivalent. Such an order is to be temporary and local in nature and countermanded as soon as the circumstances permit. It is not envisaged that fixed, large, medical facilities would be camouflaged. The STANAG defines “medical facilities” as “medical units, medical vehicles, and medical aircraft on the ground.”

Note. There is no such thing as a “camouflaged” Red Cross. When camouflaging a medical unit either cover up the Red Cross or take it down. A black cross on an olive drab or any other background is not a symbol recognized under the Geneva Conventions.

G-12. For more information on approved medical symbols, refer to Appendix F.

LOSS OF PROTECTION OF MEDICAL ESTABLISHMENTS AND UNITS

G-13. Medical assets lose their protected status by committing acts “harmful to the enemy.” (Article 21, GWS.) A warning must be given to the offending unit and a reasonable amount of time allowed to cease such activity.

ACTS HARMFUL TO THE ENEMY

G-14. The phrase “acts harmful to the enemy” is not defined in the Convention, but should be considered to include acts the purpose or effect of which is to harm the enemy, by facilitating or impeding military operations. Such harmful acts would include, for example, the use of the BAS as a shelter for able-bodied combatants, as an arms or ammunition dump, or as a military observation post. Also, covering up the crosses on dedicated ground ambulances to transport combat troops and ammunition to the FLOT. Another instance would be the deliberate siting of a medical unit in a position where it would impede an enemy attack.

WARNING AND TIME LIMIT

G-15. The enemy has to warn the unit to put an end to the harmful acts and must fix a time limit on the conclusion of which they may open fire or attack if the warning has not been complied with. The phrase in all appropriate cases recognizes that there might obviously be cases where no time limit could be allowed. A body of troops approaching a hospital and met by heavy fire from every window would return fire without delay.

USE OF SMOKE AND OBSCURANTS

G-16. The use of smoke and obscurants during MEDEVAC operations for signaling or marking LZs does not constitute an act harmful to the enemy, however, employing such devices to obfuscate a medical element’s position or location is tantamount to camouflaging; it would jeopardize its entitlement privilege status under the GWS. Refer to Army doctrine for MEDEVAC for additional information on the use of smoke and obscurants for medical operations.

CONDITIONS NOT DEPRIVING MEDICAL UNITS AND ESTABLISHMENTS OF PROTECTION

G-17. Article 22 of the GWS reads as follows: “The following conditions shall not be considered as depriving a medical unit or establishment of the protection guaranteed by Article 19: (1) That the personnel of the unit or establishment are armed, and that they use the arms in their own defense [sic], or in that of the wounded and sick in their charge. (2) That in the absence of armed orderlies, the unit or establishment is protected by a picket or by sentries or by an escort. (3) That small arms and ammunition taken from the wounded and sick and not yet handed to the proper service, are found in the unit or establishment. (4) That personnel and material [sic] of the veterinary service are found in the unit or establishment, without forming an integral part thereof. (5) That the humanitarian activities of medical units and establishments or of their personnel extend to the care of civilian wounded or sick.”

ACTS

G-18. These five conditions are not to be regarded as acts harmful to the enemy. These are particular cases where a medical unit retains its character and its right to immunity, in spite of certain appearances which might lead to a contrary conclusion or, at least, create some doubt.

DEFENSE OF MEDICAL UNITS AND SELF-DEFENSE BY MEDICAL PERSONNEL

G-19. A medical unit is granted a privileged status under the law of land warfare. This status is based on the view that medical personnel are not combatants and that their Role In the combat area is exclusively a humanitarian one. In recognition of the necessity of self-defense, however, medical personnel may be armed for their own defense or for the protection of the wounded and sick under their charge. To retain this privileged status, they must refrain from all aggressive action and may only employ their weapons if attacked in violation of the Conventions. They may not employ arms against enemy forces acting in conformity with the law of land warfare and may not use force to prevent the capture of their unit by the enemy (it is, on the other hand, perfectly legitimate for a medical unit to withdraw in the face of the enemy). Medical personnel who use their arms in circumstances not justified by the law of land warfare expose themselves to penalties for violation of the law of land warfare. Provided they have been given due warning to cease such acts, they may also forfeit the protection of the medical unit or establishment which they are protecting. Refer to AR 350-1 for further information regarding the discussion below.

- Medical personnel are not authorized crew-served or offensive weapons. They may carry small arms, such as rifles, pistols, squad automatic weapons, or authorized substitutes, in the defense of medical facilities, equipment, and personnel/patients without surrendering the protections afforded by the Geneva Conventions. Further, Army Medicine and non-Army Medicine personnel in medical units are not required to train and qualify on crew-served weapons; however, Army Medicine personnel attending training at Noncommissioned Officer Education System courses will receive weapons instruction that is part of the curriculum. This will ensure the successful completion of the course is not jeopardized by failure to attend the weapons training portion of the curriculum.
- The presence of machine guns, grenade launchers, booby traps, hand grenades, light antitank weapons, or mines (regardless of the method by which they are detonated) in or around a medical unit or establishment would seriously jeopardize its entitlement privilege status under the GWS. The *deliberate arming* of a medical unit with such items could constitute an act harmful to the enemy and cause the medical unit to lose its protection, regardless of the location of the medical unit.

Guarding Medical Units

G-20. As a rule, a medical unit is to be guarded by its own personnel, however, it will not lose its protected status if the guard is performed by a number of armed Soldiers. The military guard attached to a medical unit may use its weapons, just as armed medical personnel may, to ensure the protection of the unit. But, as in the case of medical personnel, the Soldiers may only act in a purely defensive manner and may not oppose the occupation or control of the unit by an enemy who is respecting the unit's privileged status. The status of such Soldiers is that of ordinary members of the armed forces. The mere fact of their presence with a medical unit will shelter them from attack. In case of capture, they will be POWs.

Arms and Ammunition Taken from the Wounded

G-21. Wounded persons arriving in a medical unit may still be in possession of small arms and ammunition, which will be taken from them and handed to authorities outside the medical unit. Should a unit be captured by the enemy before it is able to get rid of these arms, their presence is not of itself cause for denying the protection to be accorded the medical unit under the GWS.

Personnel and Materiel of Veterinary Services

G-22. The presence of personnel and materiel of Veterinary Services with a medical unit is authorized, even where they do not form an integral part of such unit.

Care of Civilian Wounded and Sick

G-23. A medical unit or establishment protected by the GWS may take in civilians, as well as military wounded and sick, without jeopardizing its privileged status. This clause merely sanctions what is actually done in practice.

MEDICAL CARE FOR DETAINED PERSONNEL

G-24. It is DOD policy that the United States Military Services shall comply with the principles, spirit, and intent of the international law of war, both customary and codified, to include the Geneva Conventions. As such, captured or detained personnel will be accorded an appropriate legal status under international law and conventions. Personnel in United States custody will receive medical care consistent with the standard of medical care that applies for United States military personnel in the same geographic area. Refer to DODD 2310.01E, DODI 2310.08E, JP 3-63, JP 4-02, AR 40-400, AR 190-8, and ATP 4-02.46 for additional information on medical care for detained personnel.

SECTION II – MEDICAL ETHICS

G-25. Health care personnel are well-trained in and guided by the ethics of their professional calling. This training and ethical principles, coupled with the requirements of international law as it pertains to the treatment of detainees, and civilians during conflict will ensure the ethical treatment of all sick and wounded personnel.

ETHICAL CONSIDERATIONS FOR THE MEDICAL TREATMENT OF DETAINEES

G-26. Health care personnel (particularly physicians) perform their duties consistent with the below basic principles. Health care personnel—

- Have a duty in all matters affecting the physical and BH of detainees to perform, encourage, and support, directly and indirectly, actions to uphold the humane treatment of detainees. They must ensure that no individual in the custody or under the physical control of the DOD, regardless of nationality or physical location, shall be subject to cruel, inhuman, or degrading treatment or punishment as defined in United States law.
- Charged with the medical care of detainees have a duty to protect detainees' physical and BH and provide appropriate treatment for disease. To the extent practicable, treatment of detainees should be guided by professional judgments and standards similar to those applied to personnel of the United States Military Services.
- Shall not be involved in any professional provider-patient treatment relationship with detainees the purpose of which is not solely to evaluate, protect, or improve their physical and BH.
- Whether or not in a professional provider-patient treatment relationship, shall not apply their knowledge and skills in a manner that is not applicable law or the standards set forth in DODD 2310.01E.
- Shall not certify, or participate in the certification of, the fitness of detainees for any form of treatment or punishment that is not in consonance with applicable law, or participate in any way in the administration of any such treatment or punishment.
- Shall not participate in any procedure for applying physical restraints to the person of a detainee unless such a procedure is determined to be necessary for the protection of the physical or BH or the safety of the detainee, or necessary for the protection of other detainees or those treating, guarding, or otherwise interacting with them. Such restraints, if used, shall be applied in a safe and professional manner.

G-27. Health care personnel engaged in a professional provider-patient treatment relationship with detainees shall not participate in detainee-related activities for purposes other than health care. Such health care personnel shall not actively solicit information from detainees for other than medical purposes. Health care personnel engaged in nontreatment activities, such as forensic psychology, behavioral science consultation, forensic pathology, or similar disciplines, shall not engage in any professional provider-patient treatment relationship with detainees (except in emergency circumstances in which no other health care providers can respond adequately to save life or prevent permanent impairment).

G-28. During the initial screening of detainees any preexisting medical conditions, wounds, fractures, and bruises should be noted. Documentation of these

injuries/conditions provides a baseline for each detainee which facilitates the identification of injuries which may have occurred in the detention facility.

G-29. Detainees who report for routine sick call should be visually examined to determine if any unusual or suspicious injuries are apparent. If present, the health care provider should determine from the detainee how the injuries occurred. Any injuries which cannot be explained or for which the detainee is providing evasive responses should be noted in the medical record and should be reported to the chain of command, technical medical channels, and United States Army Criminal Investigation Command.

G-30. Health care personnel may enter the holding areas of the facility for a variety of reasons. These can include, but are not limited to, conducting sanitary inspections, providing TCCC, and dispensing medications. When in the holding areas of the facility, health care personnel must be observant. Should they observe anything suspicious which might indicate that detainees are being mistreated, they should report these suspicions immediately to the chain of command. Should they observe a detainee being mistreated, they should take immediate action to stop the abuse and then report the incident.

G-31. Detained personnel must have access to the same available standard of medical care as the United States and unified action partners to include respect for their dignity and privacy. In general, the security of detainees' medical records and confidentiality of medical information will be managed the same way as for the United States and multinational forces. During detainee operations, the patient administrator, the United States Army Criminal Investigation Command, the International Committee of the Red Cross, and the medical chain of command can have access to detainee medical records besides the treating health care personnel.

G-32. Health care personnel shall safeguard patient confidences and privacy within the constraints of the law. Under United States and international law and applicable medical practice standards, there is no absolute confidentiality of medical information for any person. Detainees shall not be given cause to have incorrect expectations of privacy or confidentiality regarding their medical records and communications, however, whenever patient-specific medical information concerning detainees is disclosed for purposes other than treatment, health care personnel shall record the details of such disclosure, including the specific information disclosed, the person to whom it was disclosed, the purpose of the disclosure, and the name of the medical unit commander (or other designated senior medical activity officer) approving the disclosure. Similar to legal standards applicable to United States citizens, permissible purposes include preventing harm to any person, maintaining public health and order in detention facilities, and any lawful law enforcement or national security-related activity.

G-33. In any case in which the medical unit commander (or other designated senior medical activity officer) suspects that the medical information to be disclosed may be misused, they should seek a senior command determination that the use of the information will be consistent with the applicable standards.

G-34. The information disclosed to a physician during the course of the relationship between physician and patient is confidential to the greatest possible degree. The patient

should feel free to make a full disclosure of information to the physician in order that the physician may most effectively provide needed services. The patient should be able to make this disclosure with the knowledge that the physician will respect the confidential nature of the communication. The physician should not reveal confidential communications or information without the express consent of the patient, unless required to do so by law. The obligation to safeguard patient confidences is subject to certain exceptions, which are ethically and legally justified because of overriding social considerations. Where a patient threatens to inflict serious bodily harm to another person or to himself and there is a reasonable probability that the patient may carry out the threat, the physician should take reasonable precautions for the protection of the intended victim, including notification of law enforcement authorities.

G-35. Patient consent for the release of medical records is not required. The installation MTF commander or commander's designee, usually the patient administrator, determines what information is appropriate for release. Only that specific medical information or medical record required to satisfy the terms of a legitimate request will be authorized for disclosure.

G-36. Because the chain of command is ultimately responsible for the care and treatment of detainees, the detention facility chain of command requires some medical information. For example, detainees suspected of having infectious diseases such as tuberculosis should be separated from other detainees. Guards and other personnel who come into contact with such patients should be informed about their health risks and how to mitigate those risks.

G-37. Releasable medical information on detainees includes that which is necessary to supervise the general state of health, nutrition, and cleanliness of internees and to detect contagious diseases. Such information should be used to provide health care; to ensure health and safety of internees, Soldiers, employees, or others at the facility; to ensure law enforcement on the premises; and to ensure the administration and maintenance of the safety, security, and good order of the facility.

G-38. For additional information on medical ethics refer to the Textbooks of Military Medicine— *Military Medical Ethics, Volumes I and II*, and *Emergency War Surgery*. Both of these publications are available electronically at the Borden Institute website.

G-39. The provision of health care to detainees within the BAS or other facilities (such as dispensaries located within detention or holding facilities) is a unique role within the military structure. This Role 1s governed by rules and regulations designed to ensure the provision of health care while ensuring personal safety and maintenance of security, custody, and discipline in a detention/holding facility environment. Health care personnel must ensure that their actions, both on- and off-duty, do not undermine their ability to function effectively among detainees or compromise established health care, safety, security, and custody guidelines.

Note. The process of abiding by the principles of ethical treatment of personnel regardless of national/adversarial affiliation and navigating rules regarding employment of weapon systems, markings, and duties, can be challenging. Units are strongly encouraged to consult with their servicing Staff Judge Advocate and Unit Ministry Team for advisement.

This page intentionally left blank.

Appendix H

Tactical Standard Operating Procedures

Army Techniques Publication 3-90.90 facilitates development of SOPs in order to enhance efficiency and adaptability across the force. Army techniques publication 3-90.90 achieves this purpose through linking to a milWiki portal under the milSuite uniform resource locator containing guidance for tactical SOPs and unclassified examples of SOPs for reference. The SOP portal provides a baseline for developing new SOPs quickly and a forum for improving existing SOPs. The portal presents best practices consistent with doctrinal principles.

SPECIAL CONSIDERATIONS FOR USE OF THIS MANUAL

H-1. The Combined Arms Doctrine Directorate established the SOP portal in 2009. The authors attempted to align the original information with pertinent doctrine and regulations. Where the portal's contents differ from current doctrine and regulations, the latter take precedence. The information in the SOP portal is not authoritative doctrine. The examples in the portal do not provide ready-to-use SOPs for Army units. Soldiers developing SOPs for their units are encouraged to apply critical thinking while referring to the models and other resources to aid their own content development. At a minimum, portal users must be familiar with this ATP, ADP 5-0 and FM 6-99, AR 25-1 and AR 380-5, and DA Pam 25-403. Soldiers are encouraged to use the portal to collaborate, to improve the portal's contents, and to upload new SOP examples. The SOP portal is secure and requires an Army Knowledge Online or Defense Knowledge Online login. The portal's contents are unclassified. Neither this manual nor the SOP portal is intended to regulate the appearance or content of unit SOPs.

H-2. A *standard operating procedure* is a set of instructions covering those features of operations which lend themselves to a definite or standardized procedure without loss of effectiveness. The procedure is applicable unless ordered otherwise (JP 3-31). A SOP is both standing and standard: it instructs how to perform a prescribed and accepted process established for completing a task. Features of operations that lend themselves to standardization are common and usually detailed processes performed often and requiring minimal variation each time. Well-written and properly used unit tactical SOPs enhance effective execution of tasks; the benefits of SOPs are numerous. They reduce training time, the loss of unwritten information, the commission of errors, the omission of essential steps or processes, and the time required for completion of tasks. This does not mean, however, that carrying out SOPs never requires thought or that SOPs should never change. Indeed, tactical units must change some operating

procedures as rapidly as the OE and missions change. The SOP portal helps units avoid an unnecessary loss of effectiveness that could occur by maintaining unthinking dependence on outdated written procedures. The portal also helps units avoid a loss of effectiveness that could occur when units delay writing down processes that need to become standardized.

Note. In June 2010, JP 3-31 changed standing operating procedure to standard operating procedure. The meaning is unchanged.

SCOPE

H-3. The doctrine in this appendix provides techniques for developing unit tactical SOPs. Units throughout the Army can take advantage of technology to obtain guidance, collaborate in real time, and find information quickly. This manual and the SOP portal are intended to enhance operational adaptability Army-wide. In the short term, the information in the SOP portal will help units establish or improve SOPs more rapidly. In the long-term, the intention is that more and more units will build SOPs using the portal and the doctrine in this manual. Ideally, SOPs throughout the Army should increase in similarity as the combination of doctrinal guidance and Army-wide milWiki collaboration facilitates consensus. This will help units communicate and coordinate with one another more easily. Reassigned Soldiers and units will become familiar with SOPs in their new assignments more quickly.

SECURITY MEASURES FOR MILWIKI COLLABORATION

H-4. The milSuite and milWiki information security procedures ensure that the SOP portal is secure. The SOP portal is consistent with Department of the Army information security policies and procedures. Standard operating procedure portal users must adhere to AR 380-5. Standard operating procedure portal users must not post classified information to the portal. To develop unit SOPs, users must download and develop information on unit hardware with the appropriate classification. The Combined Arms Doctrine Directorate milWiki program manager, SOP portal content managers, and the milSuite security network enterprise managers monitor input to the portal. Managers or doctrine proponents may modify or remove content. Posts are traceable to their originator.

CAUTION

Standard operating procedure portal users must comply with AR 380-5. Do not enter any classified information about friendly or enemy tactics, techniques, and procedures in use for current operations. Develop classified unit SOPs on classified unit hardware.

STANDARD OPERATING PROCEDURE DEVELOPMENT RESOURCES

H-5. This chapter introduces using collaborative technology to enhance SOP content development. Then it discusses Army doctrine and policy in support of SOP content development. Finally, it briefly discusses resources related to coordinating operating procedures with partners.

COLLABORATIVE TECHNOLOGY FOR SOP DEVELOPMENT

H-6. Army techniques publication 3-90.90 is distinct from traditional doctrinal literature in that it links to an online portal containing guidance for developing TACSOPs, along with examples of unit SOPs. The portal serves as a forum for discussion, updates, and improvements. Soldiers may use the portal as a resource when developing unit SOPs in support of CP operations. Soldiers can refer to ATP 3-90.90 and the SOP portal to improve processes for establishing and revising SOPs and for discussing best practices in general.

H-7. The SOP portal harnesses collaborative technology to accelerate the creation and sharing of knowledge related to unit SOPs. The portal makes it easy for Soldiers to preserve, share, and adopt lessons learned among units throughout the Army. The portal's guidance and examples are not doctrinal or authoritative and, therefore, are not subject to the time-consuming staffing requirements of doctrine development. Additionally, the models do not present classified TTP used in current operations.

DOCTRINE AND POLICY TO SUPPORT STANDARDIZATION AND RECORDKEEPING

H-8. While Army units may draw on material in the SOP portal to accelerate SOP development, they also must consider pertinent Army doctrine and regulations. Additionally, commanders and staffs analyze their OE and their mission to determine what SOPs are needed and how to employ them. Commanders and staffs employ SOPs to further mission command. See FM 6-0 for more information about mission command. Paragraphs H-9 to H-12 introduce Army doctrine and policy publications to support SOP standardization and recordkeeping.

Note. Chapter 1 of FM 6-0 provides the guidelines command post operations, including the importance of establishing SOPs.

The Army Universal Task List

H-9. Army Doctrinal Reference Publication 1-03 defines Army tactical task 5.2.1.3, Establish or revise standard operating procedures as units create or modify a set of instructions covering those tasks and functions that lend themselves to a definite or standard procedure without a loss of effectiveness. The standard operating procedures are effective unless ordered otherwise to meet altered conditions. (FM 6-0) (USACAC).

H-10. Per Army Doctrinal Reference Publication 1-03, the overall goal for SOPs is to facilitate mission accomplishment and warfighting functions integration.

United States Army Report and Message Formats

H-11. Field manual 6-99 prescribes Army report and message formats. Unit SOPs must use voice and digital report and message formats from FM 6-99. Only unit commanders may authorize modifications. For occasions that FM 6-99 does not provide necessary branch-specific technical reports and messages, units still must use doctrinally established formats. Refer to the Army Publishing Directorate website to find doctrinal publications containing branch-specific formats

Department of the Army Recordkeeping Guidance

H-12. Leaders ensure units adhere to Department of the Army (DA) recordkeeping guidance when preparing and using SOPs. The SOP portal does not alter or substitute for these requirements. Standard operating procedures are a type of operational record (See table 12-1, DA Pam 25-403). Department of the Army Pamphlet 25-403 provides guidance and procedures for collecting, preparing, transferring, and preserving operational records. Army regulation 25-1 establishes policies and assigns responsibilities for managing information resources and information technology, including recordkeeping. Army Regulation 25-400-2 governs maintenance and disposition of Army information and implements policy on recordkeeping requirements (see the Army Records Information Management System website). Department of the Army Pamphlet 25-403 provides operational procedures and guidelines for Army recordkeeping. Army Regulation 380-5 discusses Army information security policy. Units use the Army writing standard to ensure SOPs and other operational records are concise and easy to read. Table H-1 summarizes these recordkeeping authorities.

Table H-1. Department of the Army recordkeeping guidance

AR 25-1, <i>Army Knowledge Management and Information Technology</i> . AR 25-400-2, <i>The Army Records Information Management System (ARIMS)</i> . AR 380-5, <i>Department of the Army Information Security Program</i> . DA Pam 25-403, <i>Guide to Recordkeeping in the Army</i> .
--

Army Standardization Policy

H-13. Authors of unit SOPs ensure alignment with higher-level SOPs. This emphasizes procedures that—

- Sustain proficiency and readiness among Soldiers and Army units.
- Reduce adverse effects of personnel turbulence following reassignment of Soldiers.
- Eliminate local modification to approved standardized practices and procedures.

H-14. Standardization throughout an organization reduces operational turbulence and confusion between units when force tailoring occurs.

DOCTRINE AND POLICY FOR COORDINATING OPERATING PROCEDURES WITH PARTNERS

H-15. Leaders consider whether unit SOPs can enhance coordination with military and nonmilitary partners. Army leaders incorporate interoperability requirements when establishing and revising SOPs, particularly regarding the command and control system. Paragraphs H-14 to H-20 briefly discuss doctrine and policy related to coordinating Army tactical unit operating procedures with partners.

COORDINATION WITH JOINT PARTNERS

H-16. Army standardization efforts related to operating procedures sometimes include joint partners. Joint doctrine expands standardization principles to include the DOD as a whole. *Standardization* is the process by which the Department of Defense achieves the closest practicable cooperation among the Services and Department of Defense agencies for the most efficient use of research, development, and production resources, and agrees to adopt on the broadest possible basis the use of: a. common or compatible operational, administrative, and logistic procedures; b. common or compatible technical procedures and criteria; c. common, compatible, or interchangeable supplies, components, weapons, or equipment; and d. common or compatible tactical doctrine with corresponding organizational compatibility (JP 4-02).

H-17. To facilitate coordination during joint operations, other Services and other partners may refer to the SOP portal.

H-18. Joint Publication 3-0 discusses considerations related to interoperability of operating procedures during joint operations. Joint publication 6-0 discusses interoperability considerations for communications during joint operations. Unit leaders

consider whether unit SOPs should incorporate coordination with joint partners, consistent with joint and Army doctrine.

Multinational Force Compatibility

H-19. Standardization efforts related to operating procedures sometimes include multinational partners. Army Regulation 34-1 establishes DA policy for enhancing multinational force compatibility through international military standardization and other Army security cooperation activities. Army Regulation 34-1 requires United States Army Training and Doctrine Command to integrate multinational force compatibility where appropriate in all assigned doctrine, organization, training, materiel, leadership and education, personnel, and facilities (also referred to as DOTMLPF) development activities. Army Regulation 34-1 also lists additional publications related to standardization for multinational operations. For information security policy related to sharing information with multinational partners, see AR 380-5 and AR 380-10. See JP 3-16 for joint doctrine related to interoperability with multinational partners. Unit leaders consider whether unit SOPs should incorporate coordination with multinational partners.

CAUTION

SOPs that support standardization for multinational operations must comply with foreign disclosure policies and procedures described in AR 380-10. This appendix provides an example of a medical platoon tactical standard operation procedure for conducting Army Health System operations.

Support for Unified Action

H-20. Unit SOPs can support unified action, which is vital to the success of stability and defense support of civil authorities operations. Unified action is the synchronization, coordination, and/or integration of the activities of governmental and nongovernmental entities with military operations to achieve unity of effort (JP 1).

H-21. Military forces conduct stability operations in coordination with diplomatic, informational, and economic instruments of national power. Army forces synchronize, coordinate, and integrate their activities with other entities to achieve common goals.

H-22. Field Manual 3-07 provides the doctrinal foundation for developing TTP for stability operations and discusses civil-military cooperation, including governmental and international partners. Military forces conduct defense support of civil authorities operations in coordination with other Services; local, state, and federal government agencies; private sector organizations; and both state National Guard and federal military forces. See JP 3-08 for joint doctrine related to coordinating military operations with nonmilitary partners. Unit leaders consider how unit SOPs can support unified action for stability and defense support of civil authorities operations.

PUBLICATION FORMAT

H-23. The medical platoon should establish a TACSOP for conducting AHS operations supporting their units for all operational contingencies. The TACSOP should be detailed and cover all aspects of unit AHS operations.

H-24. The most often used format for the TACSOP is a loose-leaf binder arrangement. Policies and procedures are subject to frequent change and a loose-leaf arrangement can be easily updated. It is also relatively inexpensive and easily produced in multiple copies at the unit level.

H-25. This TACSOP supports the battalion for all operational contingencies and is written for wartime and other operations. For more information on writing a TACSOP see ATP 3-90-90; however, it is recommended that the annex follow the format used by its higher headquarters.

ORGANIZATION

H-26. Annexes with supporting appendixes and tabs are easy to change and update; therefore, maximum use of annexes in a TACSOP is advisable. The TACSOP should be organized as follows:

- Directive.
- Table of contents.
- Record of changes and corrections.
- Annexes, appendixes, and tabs.

DIRECTIVE

H-27. The commander's directive should be the first page of the TACSOP. This directive is a letter order signed by the commander that directs implementation of the TACSOP. The directive should be on unit letterhead and in memorandum format.

TABLE OF CONTENTS

H-28. The information contained in TACSOP is variable and will depend on the type of unit and, of course, guidance and policy from the unit commander and their higher headquarters. The table of contents should have an outline of annexes, appendixes, and tabs.

RECORD OF CHANGES AND CORRECTIONS

H-29. Since information in the TACSOP is subject to frequent change, include a page in the front of the binder to record changes and corrections. This allows the user and the medical platoon leadership to easily audit that particular copy of the TACSOP. A single page formatted as shown in figure H-1 on page H-8, will serve this purpose.

RECORD OF CHANGES AND CORRECTIONS				
<i>Dental treatment facilities designation or unit designation CSOP</i>				
NUMBER	DESCRIPTION	AUTHORITY	DATE	ENTERED BY
_____	_____	_____	_____	_____
_____	_____	_____	_____	_____
_____	_____	_____	_____	_____
_____	_____	_____	_____	_____

Figure H-1. Format for changes and corrections

ANNEXES

H-30. Information in the TACSOP is incorporated into annexes dealing with general areas. Annexes are supported by appendixes and tabs that deal with more specific issues. Information in annexes and supporting appendixes and tabs should not be redundant or voluminous.

H-31. There should be sufficient detail to ensure proper performance of the task addressed or compliance with the policy prescribed. As with the TACSOP, annexes to the TACSOP are directive and address who, what, where, when, and how.

H-32. Annexes are attached in alphabetical order after the body of the table of contents, with appendixes (numerical) and tabs (alphabetical) following their supported annexes. Annexes are generally formatted in the same manner prescribed for the TACSOP; however, as a matter of expediency and economy, some material may be incorporated as an appendix or tab in its original form simply by adding a tab or appendix designator. Some examples of this method are manufacturer's instruction manuals, military technical manuals, or written policy directives from higher headquarters.

H-33. The information contained in annexes is variable and will depend on the type of unit and, of course, guidance and policy from the unit commander and their higher headquarters.

H-34. The following is an outline of annexes, appendixes, and tabs recommended for inclusion in a generic TACSOP:

- Purpose.
- Scope.
- Applicability.
- Accountability. All personnel assigned to the medical platoon as a part of their initial orientation should become familiar with and have a working knowledge of this TACSOP. Thereafter, all medical platoon personnel in leadership positions should review the TACSOP every 90 days and update or recommend changes as required. Personnel not in leadership positions should review the TACSOP a minimum of every six months or as necessary when conducting operations.

- General.
- Organization and mission.
- Medical evacuation of sick and wounded:
 - Purpose.
 - General.
 - Responsibilities for MEDEVAC.
 - Procedures for MEDEVAC.
 - Rules for employment of ground ambulance and ambulance personnel.
 - Use of AE.
- Deceased personnel.
- Detainees.
- Class VIII supply.
- Medical maintenance.
- Management of mass casualties.
- Operational public health.
- Dental services.
- Combat and operational stress control.
- Eyewear.
- Geneva Conventions compliance.
- Medical reporting.

This page intentionally left blank.

Glossary

This glossary lists acronyms and terms with Army or joint definitions. Where Army and joint definitions differ, (Army) precedes the definition. Terms for which ATP 4-02.4 is the proponent are marked with an asterisk (*). The proponent publication for other terms is listed in parentheses after the definition.

SECTION I – ACRONYMS AND ABBREVIATION

1SG	first sergeant
A/L	administrative and logistics
AAR	after action review
AATF	air assault task force
AE	aeromedical evacuation
AFMAN	Air Force Manual
AHS	Army Health System
AMC	air mission commander
AMedP	allied medical publication
AMPV	armored multi-purpose vehicle
AO	area of operations
AOC	area of concentration
APAN	all partner access network
AR	Army regulation
ATP	Army techniques publication
ATRRS	Army training requirements and resources system
AXP	ambulance exchange point
BAS	battalion aid station
BCT	brigade combat team
BH	behavioral health
BMSO	brigade medical supply office
BSA	brigade support area

Glossary

BSB	brigade support battalion
BSMC	brigade support medical company
BMSO	brigade medical supply office
C	celsius
C2	command and control
CAB	combined arms battalion
CASEVAC	casualty evacuation
CB	chemical-biological
CBPS	chemical biological protective shelter
CBRN	chemical, biological, radiological, and nuclear
CCIR	commander's critical information requirement
CCMD	combatant command
CCP	casualty collection point
CLS	combat lifesaver
COA	course of action
COSC	combat and operational stress control
COSR	combat and operational stress reactions
CPE	collective protection equipment
CPPW	chemical patient protective wrap
CPS	collective protective shelter
CRT	contact repair team
CTCP	combat trains command post
CUF	care under fire
DA	Department of the Army
DCAM	defense medical logistics standard support customer assistance module
DD	Department of Defense
DLIC	detachment left in contact
DNBI	disease and nonbattle injury
DOD	Department of Defense
DODD	Department of Defense directive
DODI	Department of Defense instruction
DRC	dental readiness classification
DTD	detailed troop decontamination

DVE	driver's vision enhancer
DZ	drop zone
EAB	echelons above brigade
ECP	entry control point
EMT	emergency medical treatment
F	fahrenheit
FDT	forward distribution team
FEBA	forward edge of the battle area
FHP	force health protection
FLOT	forward line of own troops
FM	field manual
FM	frequency modulation
FMT	forward maintenance team
FRAGORD	fragmentary order
FRSD	forward resuscitative and surgical detachment
FSC	forward support company
FSMP	forward support medical evacuation platoon
GCSS-A	global combat support system—Army
GTA	graphic training aid
H2F	holistic health and fitness
HHC	headquarters and headquarters company
HLZ	helicopter landing zone
HREC	health record
HSS	health service support
IMR	individual medical readiness
IPE	individual protective equipment
IV	intravenous
JBC-P	joint battle command - platform
JCR	joint capabilities release
JP	joint publication
LD	line of departure
LIN	line item number
LOGPAC	logistics package
LRP	logistics release point

Glossary

LSCO	large-scale combat operations
LTIOV	latest time information is of value
LZ	landing zone
M3PT	medical materiel mobilization planning tool
MASCAL	mass casualty
MC4	medical communication for combat casualty care
MCOO	modified combined obstacle overlay
MCP	maintenance control point
MCRW	medical contingency requirements workflow
MED SEC	medical section
MEDCOP	medical common operating picture
MEDEVAC	medical evacuation
MEDLOG	medical logistics
MEDO	medical operations officer
MES	medical equipment set
METT-TC	mission, enemy, terrain and weather, troops and support available, time available, and civil considerations
MGRS	military grid zone system
MLC	medical logistics company
MMB	medical battalion, multifunctional
MMIP	medical materiel information portal
MMS	medical materiel set
MODS	medical operational data system
MOPP	mission-oriented protective posture
MOS	military occupational specialty
MRC	medical readiness classification
MTF	medical treatment facility
NATO	North Atlantic Treaty Organization
NCMI	National Center for Medical Intelligence
NCO	noncommissioned officer
NCOIC	noncommissioned officer in charge
NTTP	Navy tactics, techniques, and procedures
OAKOC	observation and fields of fire, avenues of approach, key terrain, obstacles, and cover and concealment
OIC	officer in charge

OPLAN	operation plan
OPORD	operation order
PA	physician assistant
PACE	primary, alternate, contingency, and emergency
PCC	pre-combat check
PCI	pre-combat inspection
PDS	patient decontamination site
PHA	periodic health assessment
PMCS	preventive maintenance checks and service
PMI	patient movement item
POI	point of injury
PSG	platoon sergeant
PZ	pickup zone
RTD	return to duty
SB	supply bulletin
SPO	support operations
SQDLDR	squad leader
SSA	supply support activity
STANAG	standardization agreement
TACEVAC	tactical evacuation care
TACSOP	tactical standard operating procedure
TAP	toxicological agent protective
TASKORG	task organization
TB MED	technical bulletin (medical)
TC	training circular
TCCC	tactical combat casualty care
TEWLS	theater enterprise wide logistics system
TFC	tactical field care
TL	team leader
TLP	troop-leading procedures
TM	technical manual
TOE	table of organizational equipment
TTP	tactics, techniques, and procedures
UA	unit assemblage

UAL	unit assemble list
USAMMA	United States Army Medical Materiel Agency
UTM	universal transverse mercator
VCL	vapor control line
VSST	veterinary service support team
WARNORD	warning order
XO	executive officer

SECTION II – TERMS

adversary

A party acknowledged as potentially hostile to a friendly party and against which the use of force may be envisaged (JP 3-0).

after action review

A guided analysis of an organization's performance, conducted at appropriate times during and at the conclusion of a training event or operation with the objective of improving future performance. It includes a facilitator, event participants, and other observers (FM 7-0).

air assault

The movement of friendly assault forces by rotary-wing or tiltrotor aircraft to engage and destroy enemy forces or to seize and hold key terrain (JP 3-18).

ambulance control point

A manned traffic regulating, often stationed at a crossroad or road junction, where ambulances are directed to one of two or more directions to reach loading points and medical treatment facilities (ATP 4-02.2).

ambulance exchange point

A location where a patient is transferred from one ambulance to another en route to a medical treatment facility. Also called AXP (ATP 4-02.2).

ambulance loading point

This the point in the shuttle system where one or more ambulances are stationed ready to receive patients for evacuation (ATP 4-02.2).

ambulance relay point

A point in the shuttle system where one or more empty ambulances are stationed to advance to a loading point or to the next relay post to replace departed ambulances (ATP 4-02.2).

ambulance shuttle system

A system consisting of one or more ambulance loading points, relay points, and when necessary, ambulance control points, all echeloned forward from the principal group of ambulances, the company location, or basic relay points as tactically required (ATP 4-02.2).

area defense

A type of defensive operation that concentrates on denying enemy forces access to designated terrain for a specific time rather than destroying the enemy outright (ADP 3-90).

attack

An offensive operations destroys or defeats enemy forces, seizes and secures terrain, or both (ADP 3-90).

avenue of approach

(Army) A path used by an attacking force leading to its objective or to key terrain. Avenues of approach exist in all domains (ADP 3-90).

backbrief

A briefing by subordinates to the commander to review how subordinates intend to accomplish their mission (FM 6-0).

***battalion aid station**

The forward-most medically staffed treatment location organic to a maneuver battalion (ATP 4-02.4).

battle drill

A rehearsed and well understood actions made in response to common battlefield occurrences (ADP 3-90).

breach

A tactical mission task in which the unit employs all available means to break through or establish a passage through an enemy defense, obstacle, minefield, or fortification (FM 3-90-1).

casualty collection point

A location that may or may not be staffed, where casualties are assembled for evacuation to a medical treatment facility (ATP 4-02.2).

casualty evacuation

The unregulated movement of casualties that can include movement both to and between medical treatment facilities. Also called CASEVAC. See also casualty; evacuation; medical treatment facility (JP 4-02).

The movement of casualties aboard nonmedical vehicles or aircraft without en route medical care. Also called CASEVAC (FM 4-02).

combat lifesaver

A non-medical Soldier trained to provide enhanced first aid as a secondary mission. Normally, one member of each squad, team, or crew is trained (FM 4-02).

command and control

The exercise of authority and direction by a properly designated commander over assigned and attached forces in the accomplishment of the mission. Also called C2. (JP 1, Volume 2).

concealment

Protection from observation or surveillance. (FM 3-96)

cover

(Army) Protection from the effects of fires. (FM 3-96)

decisive action

(Army) The continuous, simultaneous execution of offensive, defensive, and stability operations or defense support of civil authorities tasks. (ADP 3-0)

decontamination

The process of making any person, object, or area safe by absorbing, destroying, neutralizing, making harmless, or removing chemical or biological agents, or by removing radioactive material clinging to or around it. (JP 3-11).

defensive operation

An operation to defeat an enemy attack, gain time, economize forces, and develop conditions favorable for offensive or stability operations (ADP 3-0).

delay

When a force under pressure trades space for time by slowing down the enemy's momentum and inflicting maximum damage on enemy forces without becoming decisively engaged (ADP 3-90).

detachment left in contact

An element left in contact as part of the previously designated (usually rear) security force while the main body conducts its withdrawal (FM 3-90-1).

emergency medical treatment

The immediate application of medical procedures to the wounded, injured, or sick by specially trained medical personnel.

en route care

The care required to maintain the phased treatment initiated prior to evacuation and the sustainment of the patient's medical condition during evacuation (ATP 4-02.2).

enemy

A party identified as hostile against which the use of force is authorized (ADP 3-0).

envelopment

A form of maneuver in which an attacking force seeks to avoid the principal enemy defenses by seizing objectives behind those defenses that allow the targeted enemy force to be destroyed in their current positions (FM 3-90-1).

exploitation

A type of offensive operation that usually follows a successful attack and is designed to disorganize the enemy in depth (JP 2-01.2).

field of fire

The area that a weapon or group of weapons may cover effectively from a given position (FM 3-90-1).

fixing force

A force designated to supplement the striking force by preventing the enemy from moving from a specific area for a specific time (ADP 3-90).

force health protection

Measures that promote, improve, or conserve the behavioral and physical well-being of Soldiers comprised of preventive and treatment aspects of medical functions that include: combat and operational stress control, dental services, veterinary services, operational public health, and laboratory services. Enabling a healthy and fit force, prevent injury and illness, and protect the force from health hazards (FM 4-02).

health service support

Support and services performed, provided, and arranged by the Army Medicine to promote, improve, conserve, or restore the behavioral and physical well-being of personnel by providing direct patient care that include medical treatment (organic and area support) and hospitalization, medical evacuation to include medical regulating, and medical logistics to include blood management (FM 4-02).

immediate decontamination

Decontamination carried out by individuals immediately upon becoming contaminated to save lives, minimize casualties, and limit the spread of contamination (JP 3-11).

infiltration

A form of maneuver in which an attacking force conducts undetected movement through or into an area occupied by enemy forces to occupy a position of advantage in the enemy rear while exposing only small elements to enemy defensive fires (FM 3-90-1).

key terrain

An identifiable characteristic whose seizure or retention affords a marked advantage to either combatant (ADP 3-90).

mass casualty

Any large number of casualties produced in a relatively short period of time, usually as the result of a single incident such as a military aircraft accident, hurricane, flood, earthquake, or armed attack that exceeds local logistic support capabilities. Also called MASCAL (JP 4-02).

medical evacuation

The timely and effective movement of the wounded, injured, or ill to and between medical treatment facilities on dedicated and properly marked medical platforms with en route care provided by medical personnel. Also called MEDEVAC (ATP 4-02.2).

medical readiness

A standardized system across the total force to enable the commander to measure, achieve, and sustain Soldiers' health to perform their war time requirement (MOS/AOC) from induction to separation (AR 40-502).

medical surveillance

The ongoing, systematic collection, analysis, and interpretation of data derived from instances of medical care or medical evaluation, and the reporting of population-based information for characterizing and countering threats to a population's health, well-being, and performance (JP 4-02).

military decision-making process

An iterative planning methodology to understand the situation and mission, develop a courses of action, and produce an operation plan or order. Also called MDMP (ADP 5-0).

mission command

The Army's approach to command and control that empowers subordinate decision-making and decentralized execution appropriate to the situation (ADP 6-0).

mission-oriented protective posture

A flexible system of protection against chemical, biological, radiological, and nuclear contamination in which personnel are required to wear only that protective clothing and equipment appropriate to the threat level, work rate imposed by the mission, temperature, and humidity. Also called MOPP (JP 3-11).

mobile defense

A type of defensive operation that concentrates on the destruction or defeat of the enemy through a decisive attack by a striking force (ADP 3-90).

mobility corridor

(DOD) Areas that are relatively free of obstacles where a force will be canalized due to terrain restrictions allowing military forces to capitalize on the principles of mass and speed (JP 2-01.3).

movement to contact

A type of offensive operation designed to develop the situation and to establish or regain contact (ADP 3-90).

offensive operation

An operation to defeat or destroy enemy forces and gain control of terrain, resources, and population centers (ADP 3-0).

observation

The condition of weather and terrain that permits a force to see the friendly, enemy, and neutral personnel and systems, and key aspects of the environment (FM 1-02.1).

operational decontamination

Decontamination carried out by an individual and/or a unit, restricted to specific parts of operationally essential equipment, materiel and/or working areas, in order to minimize contact and transfer hazards and to sustain operations (JP 3-11).

operational environment

A composite of the conditions, circumstances, and influences that affect the employment of capabilities and bear on the decisions of the commander. Also called OE (JP 3-0).

patient

A sick, injured or wounded individual who receives medical care or treatment from medically trained personnel (FM 4-02).

patient decontamination

The removal and/or the neutralization of hazardous levels of chemical, biological, radiological, and nuclear contamination from patients before admission into a medical treatment facility under the supervision of medical personnel to prevent further injury to the patient during the decontamination process (ATP 4-02.7).

penetration

A form of maneuver in which an attacking force seeks to rupture enemy defenses on a narrow front to disrupt the defensive system (FM 3-90-1).

pursuit

A type of offensive operation designed to catch or cut off a hostile force attempting to escape, with the aim of destroying it (ADP 3-90).

rehearsal

(Army) A session in which the commander and staff or unit practices expected actions to improve performance during execution (ADP 5-0).

retirement

When a force out of contact moves away from the enemy (ADP 3-90).

retrograde

A type of defensive operation that involves organized movement away from the enemy (ADP 3-90).

standardization

The process by which the Department of Defense achieves the closest practicable cooperation among the Services and Department of Defense agencies for the most efficient use of research, development, and production resources, and agrees to adopt on the broadest possible basis the use of: a. common or compatible operational, administrative, and logistic procedures; b. common or compatible technical procedures and criteria; c. common, compatible, or interchangeable supplies, components, weapons, or equipment; and d. common or compatible tactical doctrine with corresponding organizational compatibility (JP 4-02).

striking force

A dedicated counterattack force in a mobile defense constituted with the bulk of available combat power (ADP 3-90).

strong point

A heavily fortified battle position tied to a natural or reinforcing obstacle to create an anchor for the defense or to deny the enemy decisive or key terrain (ADP 3-90).

sustainment

The provision of logistics, financial management, personnel services, and health service support necessary to maintain operations until successful mission completion (ADP 4-0).

***tailgate medical support**

An economy of force device employed primarily to retain maximum mobility during movement halts or to avoid the time and effort required to set up a formal, operational treatment facility (for example, during rapid advance and retrograde operations) (ATP 4-02.4).

thorough decontamination

Decontamination carried out by a unit to reduce contamination on personnel, equipment, materiel and/or working areas equal to natural background or to the lowest possible levels, to permit the partial or total removal of IPE and to maintain operations with minimum degradation (JP 3-11).

threat

Any combination of actors, entities, or forces that have the capability and intent to harm U.S. forces, U.S. national interests, or the homeland (ADP 3-0).

troop leading procedures

A dynamic process used by small-unit leaders to analyze a mission, develop a plan, and prepare for an operations (ADP 5-0).

turning movement

A form of maneuver in which the attacking force seeks to avoid the enemy's principal defense positions by seizing objectives behind the enemy's current positions thereby causing the enemy force to move out of their current positions or divert major forces to meet the threat (FM 3-90-1).

warfighting function

A group of tasks and systems united by a common purpose that commanders use to accomplish missions and training objectives (ADP 3-0).

withdraw

To disengage from an enemy force and move in a direction away from the enemy (ADP 3-90).

This page intentionally left blank.

References

All websites accessed on 16 March 2021.

REQUIRED PUBLICATIONS

- ATP 4-02.1. *Army Medical Logistics*. 29 October 2015.
ATP 4-02.2. *Medical Evacuation*. 11 July 2019.
ATP 4-02.8. *Force Health Protection*. 9 March 2016.
ATP 4-02.55. *Army Health System Support Planning*. 30 March 2020.
ATP 4-25.12. *Unit Field Sanitation Teams*. 30 April 2014.
ATP 4-25.13. *Casualty Evacuation*. 15 February 2013.
FM 1-02.1. *Operational Terms*. 21 November 2019.
FM 1-02.2. *Military Symbols*. 10 November 2020.
FM 4-02. *Army Health System*. 17 November 2020.
TC 4-02.1. *First Aid*. 21 May 2016.
TC 4-02.3. *Field Hygiene and Sanitation*. 6 May 2015.

These publications are available online at:

<https://www.jcs.mil/Doctrine/Joint-Doctrine-Pubs/>.

DOD Dictionary of Military and Associated Terms. January 2021.

Military Medical Ethics, Volumes I and II. 2003 at:

<https://medcoe.army.mil/borden>.

RELATED PUBLICATIONS

These documents contain relevant supplemental information.

GENEVA CONVENTIONS

These documents are available online at:

https://www.loc.gov/rr/frd/Military_Law/Geneva_conventions-1949.html.

Convention (I) for the Amelioration of the Condition of the Wounded and Sick in Armed Forces in the Field. 12 August 1949.

Convention (II) for the Amelioration of the Condition of Wounded, Sick and Shipwrecked Members of Armed Forces at Sea. 12 August 1949.

Convention (III) relative to the Treatment of Prisoners of War. 12 August 1949.

References

Convention (IV) relative to the Protection of Civilian Persons in Time of War, 12 August 1949.

NORTH ATLANTIC TREATY ORGANIZATION STANDARDIZATION AGREEMENTS

NATO standardization agreements are available on the NATO Standards Organization Website at: <https://nso.nato.int> (account registration required).

STANAG 2132, *Documentation Relative to Initial Medical Treatment and Evacuation*, Edition 3. 11 June 2013 (AMedP-8.1, Edition A, Version 2, September 2016).

STANAG 2136, *Requirements for Water Potability during Field Operations and in Emergency Situations—Allied Medical Publication-4.9 Edition A*. 24 March 2014.

STANAG 2454, *Road Movements and Movement Control—AMovP-1(A)*, Edition 3. 27 January 2005.

STANAG 2461, *The Medical Management of CBRN Casualties - AMedP-7.1 Edition A*. 20 June 2018.

STANAG 2542, *Allied Joint Medical Planning Doctrine - AJMedP-2 Edition A*. 17 September 2018.

STANAG 2546, *Allied Joint Medical Doctrine for Medical Evacuation - AJMedP-2 Edition A*. 30 August 2018.

STANAG 2549, *Emergency Medical Care in the Operational Environment - AMedP-24*. 25 May 2011.

STANAG 2561, *Allied Joint Medical Force Health Protection Doctrine - AJMedP-4 Edition A*. 11 September 2018.

STANAG 2931, *Orders for the Camouflage of Protective Medical Emblems on Land in Tactical Operations*, Edition 4, 19 January 2018 (ATP-79, Edition B, Version 1. January 2018).

STANAG 2954, *Training of Medical Personnel for Chemical, Biological, Radiological, and Nuclear (CBRN) Defence - AMedP-7.3 Edition A*. 7 June 2016.

STANAG 3204, *Aeromedical Evacuation - AAMedP-1.1 Edition*. 6 July 2020.

STANAG 3619, *Helipad and Heliport Marking and Lighting - AATMP-12 Edition A*. 23 February 2018.

UNITED STATES CODE

These document is available online at: <https://uscode.house.gov/>.

Title 10. Armed Forces.

Title 32. National Guard.

Title 42. The Public Health and Welfare.

29 CFR 1910.120. *Hazardous waste operations and emergency response.*
Website: <https://www.ecfr.gov/>.

PUBLIC LAW

This document is available at: <http://aspe.hhs.gov/admsimp/pl104191.htm>.
Public Law 104-191. 104th Congress. *Health Insurance Portability and Accountability Act of 1996.*

DEPARTMENT OF JUSTICE PUBLICATIONS

These documents are available online at: <https://www.bop.gov>.
HSD/HPB 6031.04. *Patient Care*. 3 June 2014.

DEPARTMENT OF DEFENSE PUBLICATIONS

Department of Defense publications are available on the Executive Services Directorate website at: <https://www.esd.whs.mil/dd>.
DODD 1300.22C1. *Mortuary Affairs Policy*. 20 October 2015.
DODD 2310.01E. *DOD Defense Detainee Program*. 19 August 2014.
DODD 2311.01E. *DOD Law of War Program*. 2 July 2020.
DODD 3000.05. *Stabilization*. 13 December 2018.
DODD 5100.01. *Functions of Department of Defense and Its Major Components*. 21 December 2010.
DODD 6400.04E. *DOD Veterinary Public and Animal Health Services*. 27 June 2013.
DODD 6490.02E. *Comprehensive Health Surveillance*. 8 February 2012.
DODI 1322.24. *Medical Readiness Training (MRT)*. 16 March 2018.
DODI 1332.18. *Disability Evaluation System (DES)*. 5 August 2014.
DODI 2310.08. *Medical Program Support for Detainee Operations*. 5 September 2019.
DODI 2310.09. *Behavioral Science Support (BSS) for Detainee Operations and Intelligence Interrogations*. 5 September 2019.
DODI 6000.11. *Patient Movement (PM)*. 22 June 2018.
DODI 6000.19. *Military Medical Treatment Facility Support of Medical Readiness Skills of Health Care Providers*. 7 February 2020.
DODI 6025.19. *Individual Medical Readiness*. 9 June 2014.
DODI 6025.27. *Medical Ethics in the Military Health System*. 8 November 2017.
DODI 6040.47. *Joint Trauma System (JTS)*. 28 September 2016.
DODI 6490.03. *Deployment Health*. 19 June 2019.
JROCM 025-15. *Combat Casualty Care Medical Research and Development DOTmLPPF-P Change Request*.

References

JROCM 031-14. *Force Health Protection DOTmLPF-P Change Recommendation.*

JROCM 048-15. *Joint Theater Patient Evacuation DOTmLPF-P Change Recommendation.*

JOINT PUBLICATIONS

Most joint publications are available online at: <https://www.jcs.mil/Doctrine>.

JP 1-0. *Joint Personnel Support*. 1 December 2020.

JP 3-0. *Joint Operations*. 17 January 2017.

JP 3-08. *Interorganizational Cooperation*. 12 October 2016.

JP 3-09. *Joint Fire Support*. 10 April 2019.

JP 3-11. *Operations in Chemical, Biological, Radiological, and Nuclear Environments*. 29 October 2018.

JP 3-16. *Multinational Operations*. 1 March 2019.

JP 3-18. *Joint Forcible Entry Operations*. 27 June 2018.

JP 3-31. *Joint Land Operations*. 3 October 2019.

JP 3-63. *Detainee Operations*. 13 November 2014.

JP 4-0. *Joint Logistics*. 4 February 2019.

JP 4-02. *Joint Health Services*, 11 December 2017.

JP 5-0. *Joint Planning*. 1 December 20.

JP 6-0. *Joint Communications System*. 10 June 2015.

MIL-STD 2525D. *Joint Military Symbolology*. 10 June 2014 at: <https://assist.dla.mil> (account registration required).

MULTI-SERVICE PUBLICATIONS

AR 40-905/SECNAVINST 6401.1B AFI 48-131. *Veterinary Health Services*. 29 August 2006.

AR 190-8. *Enemy Prisoners Of War, Retained Personnel, Civilian Internees and Other Detainees {OPNAVINST 3461.6; AFJI 31-304; MCO 3461.1}*. 1 October 1997.

ATP 3-06/MCTP 12-10B. *Urban Operations*. 7 December 2017.

ATP 3-11.32/MCWP 10-10E.8/NTTP 3-11.37/AFTTP 3-2.46. *Multi-Service Tactics, Techniques, and Procedures for Chemical, Biological, Radiological, and Nuclear Passive Defense*. 13 May 2016.

ATP 3-90.99/MCTP 12-10D, *Desert Operations*, 7 April 2021.

ATP 4-02.7/MCRP 3-40A.6/NTTP 4-02.7/AFTTP 3-42.3. *Multi-Service Tactics, Techniques, and Procedures for Health Service Support In A Chemical, Biological, Radiological, and Nuclear Environment*. 15 March 2016.

- ATP 4-02.83/MCRP 3-40A.2/NTRP 4-02.21/AFMAN 44-161(I). *Multiservice Tactics, Techniques, and Procedures for Treatment of Nuclear and Radiological Casualties*. 5 May 2014.
- ATP 4-02.84/MCRP 3-40A.3/NTRP 4-02.23/AFMAN 44-156 IP. *Multi-Service Tactics, Techniques, and Procedures for Treatment of Biological Warfare Agent Casualties*. 21 November 2019.
- ATP 4-02.85/MCRP 3-40A.1/NTRP 4-02.22/AFTTP(I) 3-2.69. *Multi-Service Tactics, Techniques and Procedures for Treatment of Chemical Warfare Agent Casualties and Conventional Military Chemical Injuries*. 2 August 2016.
- FM 6-27/MCTP 11-10C. *The Commander's Handbook on the Law of Land Warfare*. 7 August 2019.
- NTTP 4-02.2M/MCRP 3-40A.7. *Patient Movement*. July 2013 at: <https://doctrine.navy.mil> (account registration required).
- TB MED 507/AFPAM 48-152(I). *Heat Stress Control and Heat Casualty Management*. 7 March 2003.
- TM 3-11.42/MCTP 10-10G/NTTP 3-11.36/AFTTP 3-2.82. *Multi-Service Tactics, Techniques, and Procedures for Installation Emergency Management*. 23 June 2014.
- TM 3-11.91/MCRP 10-10E.5/NTRP 3-11.32/AFTTP 3-2.55, *Chemical, Biological, Radiological, and Nuclear Threats and Hazards*. 13 December 2017.

ARMY PUBLICATIONS

- These documents are available online at: <https://armypubs.army.mil/>.
- ADP 3-0. *Operations*. 31 July 2019.
- ADP 3-07. *Stability*. 31 July 2019.
- ADP 3-28. *Defense Support of Civil Authorities*. 31 July 2019.
- ADP 3-37. *Protection*. 31 July 2019.
- ADP 3-90. *Offense and Defense*. 31 July 2019.
- ADP 4-0. *Sustainment*. 31 July 2019.
- ADP 5-0. *The Operations Process*. 31 July 2019.
- ADP 6-0. *Mission Command: Command and Control of Army Forces*. 31 July 2019.
- ADP 6-22. *Army Leadership and the Profession*. 31 July 2019.
- ADRP 1-03. *The Army Universal Task List*. 10 February 2015.
- AR 25-1. *Army Information Technology*. 15 July 2019.
- AR 25-400-2. *The Army Records Information Management System (ARIMS)*. 2 October 2007.
- AR 34-1. *Interoperability*. 9 April 2020.
- AR 40-3. *Medical, Dental, and Veterinary Care*. 23 April 2013.

References

- AR 40-5. *Army Public Health Program*. 12 May 2020.
- AR 40-66. *Medical Record Administration and Health Care Documentation*. 17 June 2008.
- AR 40-400. *Patient Administration*. 8 July 2014.
- AR 40-501. *Standards of Medical Fitness*. 27 June 2019.
- AR 40-502. *Medical Readiness*. 27 June 2019.
- AR 220-1. *Army Unit Status Reporting and Force Registration - Consolidated Policies*. 15 April 2010.
- AR 350-1. *Army Training and Leader Development*. 10 December 2017.
- AR 380-5. *Army Information Security Program*. 22 October 2019.
- AR 385-10. *The Army Safety Program*. 2 February 2017.
- AR 600-8-104. *Army Military Human Resource Records Management*. 7 April 2014.
- AR 635-40. *Disability Evaluation for Retention, Retirement, or Separation*. 19 January 2017.
- AR 700-138. *Army Logistics Readiness and Sustainability*. 23 April 2018.
- AR 735-5. *Property Accountability Policies*. 9 November 2016.
- AR 750-1. *Army Materiel Maintenance Policy*. 28 October 2019.
- ATP 1-05.04. *Religious Support and Internal Advisement*. 23 March 2017.
- ATP 3-20.96. *Cavalry Squadron*. 12 May 2016.
- ATP 3-20.98. *Scout Platoon*. 4 December 2019.
- ATP 3-21.20. *Infantry Battalion*. 28 December 2017.
- ATP 3-21.21. *SBCT Infantry Battalion*. 18 March 2016.
- ATP 3-21.50. *Infantry Small-Unit Mountain and Cold Weather Operations*. 27 August 2020.
- ATP 3-21.51. *Subterranean Operations*. 1 November 2019.
- ATP 3-21.90. *Tactical Employment of Mortars*. 9 October 2019.
- ATP 3-21.91. *Stryker Brigade Combat Team Weapons Troop*. 15 May 2017.
- ATP 3-90-1. *Armor and Mechanized Infantry Company Team*. 27 January 2016.
- ATP 3-90.5. *Combined Arms Battalion*. 5 February 2016.
- ATP 3-90.90. *Army Tactical Standard Operating Procedures*. 1 November 2011.
- ATP 3-90-97. *Mountain Warfare and Cold Weather Operations*. 29 April 2016.
- ATP 3-90-98. *Jungle Operations*. 24 September 2020.
- ATP 3-91. *Division Operations*. 17 October 2014.
- ATP 4-02.1. *Army Medical Logistics*. 29 October 2015.
- ATP 4-02.2. *Medical Evacuation*. 12 July 2019.
- ATP 4-02.3. *Medical Evacuation*. 9 June 2014.
- ATP 4-02.5. *Casualty Care*. 10 May 2013.

- ATP 4-02.8. *Force Health Protection*. 9 March 2016.
- ATP 4-02.10. *Theater Hospitalization*. 14 August 2020.
- ATP 4-02.19. *Dental Services*. 14 August 2020.
- ATP 4-02.25. *The Medical Detachment, Forward Resuscitative and Surgical*. 7 December 2020
- ATP 4-02.42. *Army Health System Support to Stability and Defense Support of Civil Authorities Tasks*. 9 June 2014.
- ATP 4-02.46. *Army Health System Support To Detainee Operations*. 12 April 2013.
- ATP 4-33. *Maintenance Operations*. 9 July 2019.
- ATP 4-35. *Munitions Operations and Distribution Techniques*. 5 September 2014.
- ATP 4-43. *Petroleum Supply Operations*. 6 August 2015.
- ATP 4-44. *Water Support Operations*. 2 October 2015.
- ATP 4-90. *Brigade Support Battalion*. 18 June 2020.
- ATP 5-19. *Risk Management*. 14 April 2014.
- ATP 6-0.5. *Command Post Organization and Operations*. 1 March 2017.
- ATP 7-22.1. *Holistic Health and Fitness Testing*. 1 October 2020.
- ATP 7-22.2. *Holistic Health and Fitness Drills and Exercises*. 1 October 2020.
- ATTP 3-06.11. *Combined Arms Operations in Urban Terrain*. 10 June 2011.
- CALL Handbook 19-18. *Commander and Staff Guide to Rehearsals, A No-Fail Approach*. 11 July 2019
- CALL Handbook 18-24. *The First 100 Days of Platoon Leadership, Lessons and Best Practices*. 15 May 2018
- CTA 8-100. *Army Medical Department Expendable/Durable Items*. 17 December 2004
- DA Pam 25-403. *Guide To Recordkeeping in the Army*. 11 August 2008.
- DA Pam 40-11. *Army Public Health Program*. 18 May 2020.
- DA Pam 40-502. *Medical Readiness Procedures*. 27 June 2019.
- DA Pam 220-1. *Defense Readiness Reporting System-Army Procedures*. 16 November 2011.
- DA Pam 710-2-1. *Using Unit Supply System (Manual Procedures)*. 1 December 2016.
- DA Pam 710-2-2. *Supply Support Activity Supply System: Manual Procedures*. 30 September 1998.
- DA Pam 750-8. *The Army Maintenance Management System (TAMMS) User's Manual*. 22 August 2005.
- FM 1-0. *Human Resources Support*. 1 April 2014.
- FM 1-05. *Religious Support*. 21 January 2019.
- FM 3-0. *Operations*. 6 October 2017.

References

- FM 3-04. *Army Aviation*. 6 April 2020.
- FM 3-07. *Stability*. 2 June 2014.
- FM 3-11. *Chemical, Biological, Radiological, and Nuclear Operations*. 23 May 2019.
- FM 3-20.21. *Heavy Brigade Combat Team (HBCT) Gunnery*. 3 September 2009.
- FM 3-21.38. *Pathfinder Operations*. 25 April 2006.
- FM 3-24. *Insurgencies and Countering Insurgencies*. 13 May 2014.
- FM 3-63. *Detainee Operations*. 2 January 2020.
- FM 3-90-1. *Offense and Defense Volume 1*. 22 March 2013.
- FM 3-94. *Theater Army, Corps, and Division Operations*. 21 April 2014.
- FM 3-96. *Brigade Combat Team*. 8 October 2015.
- FM 3-98. *Reconnaissance and Security Operations*. 1 July 2015.
- FM 3-99. *Airborne and Air Assault Operations*. 6 March 2015.
- FM 4-0. *Sustainment Operations*. 31 July 2019.
- FM 6-0. *Commander and Staff Organization and Operations*. 5 May 2014.
- FM 6-99. *U.S. Army Report and Message Formats*. 19 August 2013.
- FM 7-0. *Train To Win in a Complex World*. 5 October 2016.
- FM 7-22. *Holistic Health and Fitness*. 1 October 2020.
- GTA-03-06-008. *CBRN Warning and Reporting System*. 23 June 2017.
- GTA-03-08-002. *Contaminated Casualty Care*. 20 February 2017.
- GTA 03-10-001. *CBRN Individual Protective Equipment (IPE)*. 1 March 2017.
- GTA 03-10-002. *Small-Unit CBRN Detection Equipment*. 27 March 2017.
- GTA 07-40-001. *Map Reading and Land Navigation*. 1 November 2019.
- GTA 08-01-004. *MEDEVAC Request Card*. 31 July 2016.
- GTA 08-10-015. *Medical Communications for Combat Casualty Care (MC4) Pocket Guide*. 1 August 2011.
- GTA 20-01-001. *Cold Weather Smart Card*. 1 February 2011.
- GTA-21-08-001. *Risk Management Quick Reference Booklet*. 1 September 2015
- SB 8-75-11. *Department of the Army Supply Bulletin - Army Medical Department Supply Information*. 20 November 2016.
- SB 8-75-S7. *Army Medical Department Supply Information*. 20 July 2013.
- SC 6545-8. *Series of Medical Supply Catalogs*.
- TB MED 505. *Altitude Acclimatization and Illness Management*. 30 September 2010.
- TB MED 508. *Prevention and Management of Cold-Weather Injuries*. 1 April 2005.
- TB MED 750-2. *Operating Guide for TOE Medical Equipment Maintenance*. 1 November 2006.

- TC 3-97.61. *Military Mountaineering*. 26 July 2012.
- TC 8-270. *Brigade Medical Supply Office*. 2 October 2020.
- TC 8-800. *Medical Education and Demonstration of Individual Competence*. 15 September 2014.
- TC 90-1. *Training for Urban Operations*. 19 May 2008.
- TM 3-4240-288-12&P. *Operator`s and Unit Maintenance Manual Including Repair Parts and Special Tools List For Collective Protection Equipment NBC, Simplified, M20 (NSN 4240-01-166-2254)*. 20 August 1987.
- TM 10-5410-228-10. *Operator`s Manual For Chemical Biological Protective Shelter (CBPS) System (NSN 5410-01-441-8054) (Green) (5410-01-482-4633) (Tan)*. 19 March 2004.

UNITED STATES ARMY MEDICAL RESEARCH INSTITUTE OF INFECTIOUS DISEASES PUBLICATIONS

These documents are available online at: <https://www.usamriid.army.mil>.
Medical Management of Biological Casualties Handbook. September 2011.

AIR FORCE PUBLICATIONS

Most Air Force Publication is available online at: <https://www.publishing.af.mil/>
AFMAN 11-2 AEV3, Addenda-A. *Aeromedical Evacuation Operations Procedures*. 19 October 2020.

BORDEN INSTITUTE PUBLICATIONS

These documents are available online at: <https://medcoe.army.mil/borden>.
Emergency War Surgery. 2018.
Medical Management of Chemical Casualties Handbook. 2014.

PRESCRIBED FORMS

This section contains no entries.

REFERENCED FORMS

Unless otherwise indicated, DA Forms are available on the Army Publishing Directorate website at: <https://armypubs.army.mil>.
DD forms are available on the Executive Services Directorate website at: <https://www.esd.whs.mil/Directives/forms>.
SF forms are available on the U.S. General Services Administration website at: <https://www.gsa.gov/reference/forms/>.

DEPARTMENT OF THE ARMY FORMS

DA Form 1687. *Notice of Delegation of Authority - Receipt for Supplies*.

References

- DA Form 2028. *Recommended Changes to Publications and Blank Forms.*
- DA Form 2404. *Equipment Inspection and Maintenance Worksheet.*
- DA Form 2408-18. *Equipment Inspection List.*
- DA Form 3161. *Request for Issue or Turn-in.*
- DA Form 3862. *Controlled Substances Stock Record.*
- DA Form 4996-R. *Quality Control Card.*
- DA Form 4998-R. *Quality Control and Surveillance Record for TOE Medical Assemblage.*
- DA Form 5988-E. *Equipment Maintenance and Inspection Worksheet* (available through the Unit Level Logistics System).

DEPARTMENT OF DEFENSE FORMS

- DD Form 1380. *Tactical Combat Casualty Care (TCCC) Card* (available through normal supply channels).
- DD Form 1934. *Geneva Conventions Identity Card for Medical and Religious Personnel Who Serve in or Accompany Armed Forces*, (available through normal supply channels).
- DD Form 2005. *Privacy Act Statement – Health Care Records.*
- DD Form 2766. *Adult Preventive and Chronic Care Flowsheet* (available through normal supply channels).
- DD Form 2766C. *Adult Prevention and Chronic Care Flowsheet (Continuation Sheet)*. (Available through normal supply channels).
- DD Form 2795. *Pre-Deployment Health Assessment* (available through MEDPROS).
- DD Form 2796. *Post Deployment Health Assessment (PDHA)* (available through the Medical Protection System).
- DD Form 2697. *Report of Medical Assessment.*
- DD Form 3024. *Annual Periodic Health Assessment*, (available through MEDPROS).

STANDARD FORMS

- SF 558. *Medical Record - Emergency Care and Treatment.*
- SF 600. *Chronological Record of Medical Care.*
- SF 603. *Medical Record – Dental.*

WEBSITES

- All Partner Access Network at: <https://www.apan.org/>
- Armed Forces Radiobiology Research Institute at: <https://www.usuhs.edu/afri>
- Army Medical Logistics Command at: <https://www.amlc.army.mil/>
- Army Publishing Directorate at: <https://armypubs.army.mil>

Army Records Information Management System at: www.arims.army.mil
Army Training Requirements and Resources System at:
<https://www.atrrs.army.mil>
Borden Institute at: <https://medcoe.army.mil/borden>
Centers for Disease Control and Prevention at: <https://www.cdc.gov/>
Defense Logistics Agency at: <https://www.dla.mil/>
Deployed Medicine at: <https://deployedmedicine.com/>
Force Management System at: <https://fmsweb.fms.army.mil>
Joint Medical Logistics Functional Development Center at:
<https://jml149.dmlss.detrick.army.mil/resourcecenter/>
Joint Worldwide Intelligence Communications System at: <https://www.dia.ic.gov>
Journal of Special Operations Medicine at: <http://www.jsomonline.org/>
The United States Army Medical Materiel Agency at:
<https://www.amlc.army.mil/USAMMA/>
Medical Materiel Information Portal at:
<https://a01.usamma.amedd.army.mil/mmip>
Medical Operational Data System at: <https://www.mods.army.mil/>
Medical Protection System at: <https://medpros.mods.army.mil/>
Medical Services Information Logistics System at:
<https://a01.usamma.amedd.army.mil/mmip>
Military health system at:
<https://health.mil/Training-Center/Defense-Medical-Readiness-Training-Institute/Emergency-Preparedness-Response-Course-CBRNE>
National Center for Medical Intelligence at: <https://www.dia.smil.mil> and
<https://www.ncmi.dodiis.mil/>
United States Army Medical Research Institute of Chemical Defense at:
<https://usamricd.apgea.army.mil/>
United States Army Medical Research Institute of Infectious Diseases at:
<https://www.usamriid.army.mil/>

This page intentionally left blank.

Index

Entries are by paragraph number unless indicated otherwise.

A

after action reviews, 2-200
ambulance exchange point (AXP), 1-147
ambulance shuttle system, 1-151
army health system (AHS) support
for the defense, 3-47
for the offense, 3-2
in mountain warfare and cold weather operations, 3-119
to air assault operations, 3-252
to airborne operations, 3-268
to defense support of civil authorities operations, 3-101
to desert operations, 3-199
to detainees, 4-152
to jungle operations, 3-181
to night operations, 3-107
to stability operations, 3-101
to subterranean operations, 3-228
to urban operations, 3-224

to wet-gap crossing operations, 3-241

B

battalion aid station (BAS), 1-1
battalion aid station in a biological environment, 5-55
battalion aid station in a chemical environment, 5-41
battalion aid station in a nuclear environment, 5-64
battalion surgeon, 1-53
battle drill, 2-182
establish a battalion aid station, B-3
establish a casualty collection point, B-8
establish a patient decontamination site, B-10
react to mass casualty, B-5
brigade support medical company, 1-181
brigade surgeon, 1-176

C

casualty collection point (CCP) operations, 1-156
casualty evacuation, 1-37
casualty evacuation capabilities, table C-2

casualty evacuation capabilities Navy and Marines, table C-3
chemical biological protective shelter employment, 5-146
Class VIII (medical), 4-36
classes of supply, 4-17, table 4-2
collective protective shelter system, 5-138
collective protective shelter system, battalion aid station, 5-144
collective protective shelter system, M20, 5-152
combat lifesaver (CLS), 1-93
combat lifesaver training, E-4
combat medic, 1-92
combat and operational stress control forward support section, 1-195
contact repair team, 1-198
contamination zones, 5-120

D

decontamination of the battalion aid station, 5-84
decontamination levels, 5-28, table 5-3
decontamination line equipment and supplies, table 5-8

Entries are by paragraph number.

disposition of human remains, 4-149

E

emergency care sergeant (senior medic), 1-91

F

field sanitation team training, E-34

field surgeon, 1-73

five-paragraph operation order, 2-125

force health protection (FHP)

mission, 1-11

responsibilities, table D-1

forecasting logistics, 4-29

forward distribution team, 1-197

forward resuscitative and surgical detachment, 1-182

forward support medical evacuation platoon, 1-196

H

health service support (HSS) mission, 1-12

health threat, 1-44, table 1-3

helicopter landing zone, C-10, figure C-1, table C-6

M

maintenance categories, 4-124

marking contaminated areas, 5-22, table 5-2

medical command and control mission, 1-13.

medical company, ground ambulance section, 1-192

medical equipment set management, 4-113

medical ethics, G-25

medical evacuation, 1-28

medical evacuation capabilities, table C-1

medical functions, 1-5, figure 1-1

medical operations officer, 1-54

medical platoon capabilities, 1-50

medical platoon, employment 1-116

medical platoon key personnel, 1-49

medical platoon sergeant, 1-62

medical platoon task organization, 1-95

medical push-packages, 4-62

medical readiness, D-4

military decision-making process, 2-140, figure 2-7

military decision-making process, steps, 2-146

mission-oriented protective posture, 5-1, table 5-1

P

patient decontamination, 5-93

patient decontamination principles, 5-113

patient decontamination site, 5-154

closing, 5-277, table 5-12
components, 5-201, table 5-4

physician assistant, 1-74

pre-combat checks, 2-197, table 2-6

pre-combat instructions, 2-198, table 2-6

preventive medicine team, 1-193

principles of the Army Health System, 1-14

prolonged care, 1-141

protection and identification of medical units, G-8

R

rehearsals, 2-174

resupply methods, 4-80

resupply procedures, 4-91

resupply techniques, 4-93

risk management, 2-169

roles of care, 1-21

S

splitting the battalion aid station, 1-136

sustainment functions, 4-16, table 4-1

sustainment overlay, 4-75, figure 4-3, figure 4-4

sustainment planning factors, 4-19

T

tactical combat casualty care, 1-30

tailgate medical support, 1-132

treatment squad leader, 1-75

troop leading procedures, 2-23

U

United States Navy ship capabilities, table C-4

unmasking procedures, 5-285

V

vehicle recovery, 4-142

veterinary service support team, 1-194

W

work/rest cycles and water consumption, table 5-5

By Order of the Secretary of the Army:

JAMES C. MCCONVILLE
General, United States Army
Chief of Staff

Official:



KATHLEEN S. MILLER
Administrative Assistant
to the Secretary of the Army
2112412

DISTRIBUTION:

Active Army, Army National Guard, and United States Army Reserve: To be distributed in accordance with the initial distribution number (IDN) 345318, requirements for ATP 4-02.4.

This page intentionally left blank.

PIN: 208989-000

