

# TECHNICAL MANUAL

## UNIT AND DIRECT SUPPORT MAINTENANCE MANUAL INCLUDING REPAIR PARTS AND SPECIAL TOOLS LIST

MONOCULAR NIGHT VISION DEVICE (MNVD)  
AN/PVS-14  
(NSN 5855-01-432-0524) (EIC: N/A)

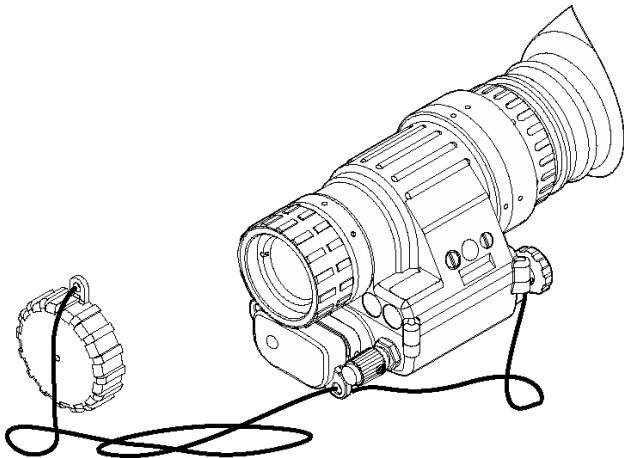

Introduction, page 1-1

Equipment Description and Data, page 1-9

Preventive Maintenance Checks and Services, page 2-3

Image Intensifier Inspection Criteria, page 2-3

Unit Troubleshooting, page 2-3

Unit Maintenance Procedures, page 2-4

Direct Support Servicing, page 3-2

Direct Support Troubleshooting, page 3-3

Direct Support Maintenance Procedures, page 3-20

**DISTRIBUTION STATEMENT C.** Distribution authorized to U.S. Government agencies and their contractors. This publication is required for administration and operational purposes, as determined 15 August 1992. Other requests for this document shall be referred to either: Commander, U.S. Army Communications-Electronics Command and Fort Monmouth, ATTN: AMSEL-LC-LEO-E-ED-P, Fort Monmouth, NJ 07703-5000; or: Commandant of the Marine Corps (ARD), Washington, DC 20380-0001.

**DESTRUCTION NOTICE** - For unclassified, limited documents, destroy by any method that will prevent disclosure of contents or reconstruction of the document.

DEPARTMENT OF THE ARMY  
AND HEADQUARTERS, MARINE CORPS

1 June 2000

PCN 184 102711 00

**WARNING**

Do not carry batteries in pockets containing metal objects such as coins, keys, etc. Metal objects can cause batteries to short circuit and become very hot.

**WARNING**

**Toxic Material**

The image intensifier's phosphor screen contains toxic materials.

- If an image intensifier breaks, be extremely careful to avoid inhaling the phosphor screen material. Do not allow the material to come in contact with the mouth or open wounds on the skin.
- If the phosphor screen material contacts your skin, wash it off immediately with soap and water.
- If you inhale/swallow any phosphor screen material, drink a lot of water, induce vomiting, and seek medical attention as soon as possible.

**WARNING**

The IR source is a light that is invisible to the unaided eye for use during conditions of extreme darkness. However, the light from the IR source can be detected by the enemy using night vision devices.

**WARNING**

**Personnel Injury**

- Serious injury may result if the nitrogen tank valve breaks off due to tank upset. If the tank valve breaks, the tank can be propelled by the escaping gas and strike you or others.
- Always secure the tank to an upright support before removing the tank valve guard and attaching the regulator valve to the tank.

**WARNING**

**EQUIPMENT LIMITATIONS**

To avoid physical and equipment damage when using the MNVD carefully read and understand the following safety precautions.

- The MNVD requires some night light (moonlight, starlight, etc.) to operate. The level of performance depends upon the level of light.
- Night light is reduced by passing cloud cover, while operating under trees, in building shadows, etc.
- The MNVD is less effective viewing into shadows and other darkened areas.
- The MNVD is less effective through rain, fog, sleet, snow, or smoke.
- The MNVD will not see through dense smoke.

**WARNING**

The monocular will not be turned off automatically when flipped up. The monocular must be turned off by the power switch.

**WARNING**

The compass illuminator can be seen by others using night vision devices.

**WARNING**

When installing the headmount over the protective mask, be careful not to break the protective mask seal around your face.

**WARNING**

Do not use contaminated eyecup or eyeguard. They must be replaced.

**FIRST AID**

For first aid or artificial respiration, see FM 21-11, First Aid for Soldiers.

**UNIT AND DIRECT SUPPORT MAINTENANCE MANUAL  
INCLUDING REPAIR PARTS AND SPECIAL TOOLS LIST**

**MONOCULAR NIGHT VISION DEVICE (MNVD) AN/PVS-14  
(NSN 5855-01-432-0524) (EIC: N/A)**

**REPORTING ERRORS AND RECOMMENDING IMPROVEMENTS**

You can help improve this manual. If you find any mistakes or if you know of a way to improve the procedures, please let us know. Mail your letter, DA Form 2028 (Recommended Changes to Publications and Blank Forms), or DA Form 2028-2 (Recommended Changes to Equipment Technical Publications) located in the back of this manual directly to: Commander US Army Communications-Electronics Command and Fort Monmouth, ATTN: AMSEL-LC-LEO-D-CS-CFO, Fort Monmouth, New Jersey 07703-5000. The Fax number is 732-532-1413, DSN 992-1413. You may also email your recommendations to [AMSEL-LC-LEO-PUBS-CHG@cecom3.monmouth.army.mil](mailto:AMSEL-LC-LEO-PUBS-CHG@cecom3.monmouth.army.mil). Marine Corps personnel send NAVMC 10772 to: Commander, Marine Corps Logistics Base (Code 826) 814 Radford Blvd, Albany, GA 31704-1128.

A reply will be furnished to you.

**TABLE OF CONTENTS**

<u>Paragraph</u>	<u>Title</u>	<u>Page</u>
	How to Use This Manual .....	vii
CHAPTER 1	<b>Introduction</b> .....	1-1
Section I	General Information .....	1-1
1-1	Scope.....	1-1
1-2	Maintenance Forms, Records, and Reports .....	1-2
1-3	Destruction of Electronic Materiel to Prevent Enemy Use.....	1-2
1-4	Preparation for Storage or Shipment.....	1-2
1-5	Official Nomenclature, Names, and Designations.....	1-2
1-6	Reporting Equipment Improvement Recommendations (EIR) .....	1-3
1-7	Warranty Information.....	1-4
1-8	Corrosion Prevention and Control (CPC).....	1-9
Section II	<b>Equipment Description and Data</b> .....	1-9
1-9	Equipment Characteristics, Capabilities, and Features.....	1-9
1-10	Location and Description of Major Components .....	1-10
1-11	Configuration of Image Intensifier.....	1-14
1-12	Equipment Data .....	1-15

**TABLE OF CONTENTS — Continued**

<u>Paragraph</u>	<u>Title</u>	<u>Page</u>
Section III	Principles of Operation.....	1-16
1-13	Mechanical Functions .....	1-16
1-14	Optical Functions .....	1-16
1-15	Electronic Circuit Functions .....	1-17
CHAPTER 2	UNIT MAINTENANCE INSTRUCTIONS .....	2-1
Section I	Repair Parts, Tools, Special Tools, TMDE, and Support Equipment .....	2-2
2-1	Common Tools and Equipment.....	2-2
2-2	Special Tools, TMDE, and Support Equipment .....	2-2
2-3	Repair Parts.....	2-2
Section II	Service Upon Receipt .....	2-2
2-4	Site and Shelter Requirements .....	2-2
2-5	Service Upon Receipt of Material.....	2-2
2-6	Installation .....	2-3
Section III	<b>Preventive Maintenance Checks and Services</b>	
2-7	Preventive Maintenance Checks and Services (PMCS) Table .....	2-3
2-8	<b>Image Intensifier Inspection Criteria</b> .....	2-3
Section IV	<b>Unit Troubleshooting</b> .....	2-3
2-9	Unit Troubleshooting.....	2-3
2-10	Resolution Check Using TS-4348/UV Test Set .....	2-3
Section V	<b>Unit Maintenance Procedures</b> .....	2-4
2-11	Removal and Installation of Components.....	2-4
2-12	Removal and Installation of Power Switch Knob .....	2-4
2-13	Removal and Installation of Gain Control Knob.....	2-5
2-14	Removal and Installation of Batteries/Battery Cartridge .....	2-5
2-15	Removal and Installation of Browpads .....	2-6
2-16	Removal and Installation of Neck Pads.....	2-6
2-17	Removal and Installation of Chinstrap.....	2-8
2-18	Removal and Installation of Cross Strap .....	2-9
2-19	Removal and Installation of Helmet Mount.....	2-10
2-20	Removal and Installation of Magnet on Metal Helmet Mount .....	2-11
2-21	Repainting and Refinishing Requirements .....	2-12
2-22	Lubrication Requirements .....	2-12
Section VI	Preparation for Storage and Shipment.....	2-12
2-23	Packing the MNVD .....	2-12

**TABLE OF CONTENTS — Continued**

<u>Paragraph</u>	<u>Title</u>	<u>Page</u>
CHAPTER 3	DIRECT SUPPORT MAINTENANCE INSTRUCTIONS .....	3-1
Section I	Repair Parts, Tools, Special Tools, TMDE, and Support Equipment .....	3-1
3-1	Common Tools and Equipment .....	3-1
3-2	Special Tools, TMDE, and Support Equipment.....	3-2
3-3	Repair Parts .....	3-2
Section II	Service Upon Receipt.....	3-2
3-4	Site and Shelter Requirements.....	3-2
3-5	Service Upon Receipt of Material .....	3-2
Section III	<b>Direct Support Servicing</b> .....	3-3
3-6	Scope.....	3-3
Section IV	<b>Direct Support Troubleshooting</b> .....	3-3
3-7	Direct Support Troubleshooting .....	3-3
3-8	TS-3895A/UV Preparation for Use .....	3-7
3-9	Testing Resolution Using TS-3895A/UV.....	3-7
3-10	Electrical Troubleshooting .....	3-13
3-11	Black Spot Check.....	3-14
Section V	<b>Direct Support Maintenance Procedures</b> .....	3-20
3-12	Removal, Repair, and Replacement of Eyepiece Lens.....	3-20
3-13	Setting Zero Diopter for Eyepiece.....	3-29
3-14	Removal and Installation of Battery Housing .....	3-34
3-15	Removal and Installation of Image Intensifier .....	3-39
3-16	Removal and Installation of Objective Lens.....	3-43
3-17	Objective Lens Infinity Focus Setting.....	3-47
3-18	Removal and Installation of Monocular Housing.....	3-49
3-19	Purging.....	3-50
3-20	Operational Checks.....	3-54
Section VI	Preparation for Storage and Shipment .....	3-54
3-21	Packing the MNVD .....	3-54
3-22	Shipping the Image Intensifier .....	3-54
APPENDIX A	REFERENCES	
A-1	Scope.....	A-1
A-2	Forms.....	A-1
A-3	Field Manuals.....	A-1
A-4	Technical Manuals .....	A-1
A-5	Miscellaneous Publications .....	A-1
A-6	Marine Corps Use .....	A-2

**TABLE OF CONTENTS — Continued**

<u>Paragraph</u>	<u>Title</u>	<u>Page</u>
APPENDIX B	MAINTENANCE ALLOCATION CHART (MAC) (ARMY ONLY)	
Section I	Introduction.....	B-1
B-1	The Army Maintenance System, MAC .....	B-1
B-2	Maintenance Functions.....	B-1
B-3	Explanation of Columns in the MAC, Section II.....	B-2
B-4	Explanation of Columns in Tools and Test Equipment Requirements, Section III.....	B-3
B-5	Explanation of Columns in Remarks, Section IV .....	B-3
Section II	Maintenance Allocation Chart for AN/PVS-14 .....	B-4
Section III	Tools and Test Equipment Requirements for AN/PVS-14 .....	B-5
Section IV	Remarks .....	B-6
APPENDIX C	REPAIR PARTS AND SPECIAL TOOLS LIST	
Section I	Introduction.....	C-1
C-1	Scope .....	C-1
C-2	General.....	C-1
C-3	Explanation of Columns (Sections II and III) .....	C-1
C-4	Explanation of Columns (Section IV).....	C-4
C-5	Special Information .....	C-5
C-6	How to Locate Repair Parts .....	C-5
C-7	Abbreviations.....	C-5
Section II	Repair Parts List .....	C-6
	AN/PVS-14 .....	C-7
	Monocular Assembly .....	C-9
	Eyepiece Assembly .....	C-11
	Headset Assembly.....	C-13
Section III	Special Tools List.....	C-15
Section IV	Cross-Reference Indexes .....	C-16
APPENDIX D	EXPENDABLE AND DURABLE ITEMS LIST	
Section I	Introduction.....	D-1
D-1	Scope .....	D-1
D-2	Explanation of Columns .....	D-1
Section II	Expendable and Durable Items List .....	D-2
APPENDIX E	ILLUSTRATED LIST OF MANUFACTURED ITEMS	
Section I	Introduction.....	E-1
Section II	Manufactured Items Part Number Index .....	E-1
Section III	Manufactured Items Illustrations .....	E-2
GLOSSARY		
Section I	Abbreviations .....	Glossary-1
Section II	Definitions of Unusual Terms .....	Glossary-2
ALPHABETICAL INDEX .....		Index-1

**TABLE OF CONTENTS — Continued**

**List of Tables**

<u>Table</u>	<u>Title</u>	<u>Page</u>
1-1	Nomenclature Cross- Reference List.....	1-2
1-2	Operator Adjustment Limits.....	1-15
1-3	Electrical Data.....	1-15
1-4	Mechanical Data.....	1-15
1-5	Optical Data.....	1-15
1-6	Environmental Data.....	1-15
3-1	Troubleshooting.....	3-5
3-2	Monocular Allowable Black Spots and Sizes.....	3-18

**List of Figures**

<u>Figure</u>	<u>Title</u>	<u>Page</u>
1-1	Warranty Expiration Label Location.....	1-4
1-2	Monocular Night Vision Device (MNVD), AN/PVS-14.....	1-11
1-3	Monocular Night Vision Device (MNVD), AN/PVS-14 and Subassemblies.....	1-13
1-4	Mechanical Functions of the MNVD.....	1-16
1-5	MNVD Optical Function Diagram.....	1-16
1-6	Electrical Function of Monocular.....	1-17
2-1	Headmount Components Removal and Installation.....	2-7
2-2	Lacing of Right and Left Neck Pad Straps.....	2-8
2-3	Lacing of Sliding Bar Buckles.....	2-9
2-4	Installation of Helmet Mount.....	2-10
2-5	Magnet, Metal Helmet Mount.....	2-11
3-1	Location of Major Components on Test Set.....	3-9
3-2	Inserting Monocular into Test Set.....	3-10
3-3	Low light Element in Resolution Test Pattern.....	3-11
3-4	High Light Element in Resolution Test Pattern.....	3-12
3-5	Image Intensifier Contact Pin Location.....	3-14
3-6	Dark Room Setup with Test Fixture.....	3-15
3-7	Dark Room Setup with Tripod.....	3-16
3-8	Black Spot Evaluation.....	3-19
3-9	Loosening Eyepiece Locking Ring.....	3-21
3-10	Components of Eyepiece Lens.....	3-23
3-11	Inserting Eyepiece Lens Cell into Eyepiece Focus Ring.....	3-25
3-12	Identifying the Limits for Diopter Plus (+) Travel.....	3-25
3-13	Applying Epoxy Adhesive to Eyepiece Retaining Ring.....	3-27
3-14	Applying Lubricant to Inside of Monocular Housing.....	3-28
3-15	Setting Zero Diopter.....	3-28
3-16	Attaching Collimator and Diopter Scope.....	3-30
3-17	Properly Focused Diopter Image Using TS-3895A/UV.....	3-31
3-18	Battery Housing Connections.....	3-36
3-19	Installing O-Ring.....	3-37



TABLE OF CONTENTS — Continued

List of Figures - Continued

<u>Figure</u>	<u>Title</u>	<u>Page</u>
3-20	Wire Connections .....	3-37
3-21	Tightening Screws .....	3-38
3-22	Removal of Tube Retainer .....	3-40
3-23	Inserting Tube into Monocular Housing.....	3-41
3-24	Light Pipe.....	3-41
3-25	Identifying Slots for Tube Retainer Wrench.....	3-43
3-26	Removing Close Focus Stop Ring .....	3-44
3-27	Installation of Close Focus Stop Ring .....	3-45
3-28	Cleaning Excess Sealing Compound.....	3-46
3-29	Nitrogen Purging Equipment Setup.....	3-51
C-1	Monocular Night Vision Device (MNVD), AN/PVS-14 and Accessories .....	C-6
C-2	Monocular Assembly .....	C-8
C-3	Eyepiece Assembly .....	C-10
C-4	Headset Assembly.....	C-12
C-5	Special Tools .....	C-14
E-1	Black Spot Test Stand .....	E-2

## **HOW TO USE THIS MANUAL**

- **USAGE**

You must familiarize yourself with the entire maintenance procedure before beginning the maintenance task. Read and follow all warning and caution notices.

- **Manual Overview**

The contents of each chapter are listed at the beginning of the chapter. This listing includes the paragraph title and page number. Additional references to the contents of this manual can be found in the index at the back of the manual. This manual also contains the Repair Parts and Special Tools List (RPSTL) in Appendix C for ordering repair parts. Appendix C gives details for using the RPSTL.

- **Special Feature**

A locator is provided on the right-hand border of the front cover. This gives the location of the information most frequently used. To find the topic UNIT TROUBLESHOOTING, open the manual to the correct page by using the black tab on the side of the manual that lines up with the topic UNIT TROUBLESHOOTING.

## CHAPTER 1 INTRODUCTION

---

	<u>Page</u>
Overview .....	1-1
Scope .....	1-1
Maintenance Forms, Records, and Reports .....	1-2
Destruction of Electronic Materiel to Prevent Enemy Use .....	1-2
Preparation for Storage or Shipment .....	1-2
Official Nomenclature, Names, and Designations .....	1-2
Reporting Equipment Improvement Recommendations (EIR) .....	1-3
Warranty Information .....	1-4
Corrosion Prevention and Control (CPC) .....	1-9
Equipment Characteristics, Capabilities, and Features .....	1-9
Location and Description of Major Components .....	1-10
Configuration of Image Intensifier .....	1-14
Equipment Data .....	1-15
Mechanical Functions .....	1-16
Optical Functions .....	1-16
Electronic Circuit Functions .....	1-17

### **OVERVIEW**

Chapter 1 of this technical manual is intended to give you information regarding the type of equipment, its characteristics, and the principles of operation that will help you maintain it properly.

### **Section I. General Information**

#### **1-1 SCOPE**

- a. Type of Manual. Unit and Direct Support Maintenance including Repair Parts and Special Tools List (RPSTL).
- b. Model Number and Equipment Name. Monocular Night Vision Device (MNVD) AN/PVS-14, hereinafter referred to as the MNVD.
- c. Purpose of Equipment. The MNVD is a self-contained night vision device that enables improved night vision using ambient light from the night sky (moon, stars, skyglow, etc.)

**1-2 MAINTENANCE FORMS, RECORDS, AND REPORTS**

Department of the Army forms and procedures used for equipment maintenance will be those prescribed by DA Pam 738-750, as contained in Maintenance Management Update. Refer to the latest issue of DA Pam 25-30 to determine whether there are new editions, changes or additional publications or forms pertaining to this equipment.

Marine Corps personnel refer to the on-line MCPDS, Marine Corps Publications Distribution System.

Marine Corps Ground Equipment Record Procedures. Marine Corps personnel refer to TM 4700-15/1 for disposition of forms and records required for Marine Corps equipment.

**1-3 DESTRUCTION OF ELECTRONIC MATERIEL TO PREVENT ENEMY USE**

For procedures to destroy this equipment to prevent its use by the enemy, refer to TM 750-244-2, Procedures for Destruction of Electronic Materiel to Prevent Enemy Use (Electronics Command). **Marine users**, render the MNVD inoperable by smashing, scattering or burying disassembled pieces, burning, or destroying by weapons fire.

**1-4 PREPARATION FOR STORAGE OR SHIPMENT**

See Chapter 2, paragraph 2-23, for instruction regarding preparation for storage or shipment of the MNVD and Chapter 3, and paragraph 3-22 for packing and shipping the image intensifier.

**1-5 OFFICIAL NOMENCLATURE, NAMES, AND DESIGNATIONS**

Table 1-1 provides a cross-reference of common names and official terms. Except in the Appendices, the common names will be used. The official names are used in the Appendices because they reflect the provisioning nomenclature.

**Table 1-1. Nomenclature Cross-Reference List.**

COMMON NAME	OFFICIAL NOMENCLATURE
3X Magnifier	Magnifier Lens Assembly
Batteries	Battery, Nonrechargeable
Battery Cartridge	Cover, Battery Retainer
Carrying Case	Case, Infrared Equipment
Carrying Case Strap	Strapping
Chinstrap	Strap, Helmet
Close Focus Stop	Ring, Retaining, Optical
Compass	Compass Assembly
Cross Strap	Strapping
Demist Shield	Lens, Infrared Receiver
Eyeguard	Eyeguard, Optical
Eyepiece Lens	Eyepiece Assembly
Eyepiece Lens Cap	Cap, Protective, Dust
Eyepiece Retaining Ring	Adapter Assembly, Interface Device
Headmount	Headset Assembly

**1-5 OFFICIAL NOMENCLATURE, NAMES, AND DESIGNATIONS – Continued**

**Table 1-1. Nomenclature Cross-Reference List - Continued.**

COMMON NAME	OFFICIAL NOMENCLATURE
Headmount/Helmet Mount Adapter	Adapter, Headset
Helmet Mount	Mount, Viewer
Image Intensifier	Image Intensifier, Night Vision
LIF	Filter, Infrared Light
Light Pipe	Light Pipe, Fiber Optic
Locking Ring	Ring, Retaining, Optical
Medium Browpad	Browpad Assy, Medium
Monocular	Monocular Assy
Monocular Housing	Cell, Optical Element
Neck Cord	Cord, Fibrous
Neck Pad	Neck Pad Assembly
Objective Lens	Lens, Optical Instrument
Objective Lens Cap	Cap, Protective, Dust
O-Ring	Packing, Preformed
Purge Device	Device, Purge
Purge Screw	Screw, Machine
Rear Cover	Rear Cover Assembly
Sacrificial Window	Window, Sacrificial
Screw	Screw, Cap, Socket, Hex
Shipping and Storage Case	Case, Shipping/Storage
Side Strap	Strap, Webbing
Tethering Cord	Clip, Retaining
Thick Browpad	Browpad Assy, Thick
Thin Browpad	Browpad Assy, Thin
Weapon Mount	Bracket Mounting

**1-6 REPORTING EQUIPMENT IMPROVEMENT RECOMMENDATIONS (EIR)**

If your MNVD needs improvement, let us know. Send us an EIR. You, the user, are the only one who can tell us what you don't like about the design. Put it on a Standard Form SF 368 Product Quality Deficiency Report. Mail it to Commander, US Army Communications-Electronics Command and Fort Monmouth, ATTN: AMSEL-LC-LEO-D-CS-CFO, Fort Monmouth, New Jersey 07703-5000. We will send you a reply.

**MARINE CORPS PERSONNEL** are encouraged to submit SF 368 in accordance with MCO 4855.10 (Quality Deficiency Report).

## 1-7 WARRANTY INFORMATION

MNVD is warranted by the manufacturer to conform to design and manufacturing requirements, to remain free from defects in materials and workmanship, and to conform to performance specifications. The warranty expiration date is printed on a label affixed to the end item and a separate label affixed to the image intensifier. The Direct Support (DS)/Intermediate maintenance level personnel make the determination of a warranty defect. If a warranty defect is detected, the product (either the end item or the image intensifier) is returned directly to the manufacturer for warranty service in accordance with applicable service (Army, Navy, and Marine Corps) procedures. Warranty defects may consist of the following:

- Image intensifier does not light up.
- Image tube fails the low light resolution and/or high light and resolution.
- Image intensifier exhibits any one, or more, of the operational defects described in "Inspection Criteria for Image Intensifier Operation" as defined in the Operator's Maintenance Manual (such as, shading, edge glow, flashing, flickering or intermittent operation).
- Fails the electrical troubleshooting test.
- Obvious mechanical malfunction with no evidence of severe trauma that indicates customer damage.

The manufacturer will use the same list of criteria in verifying a defect covered by the warranty.

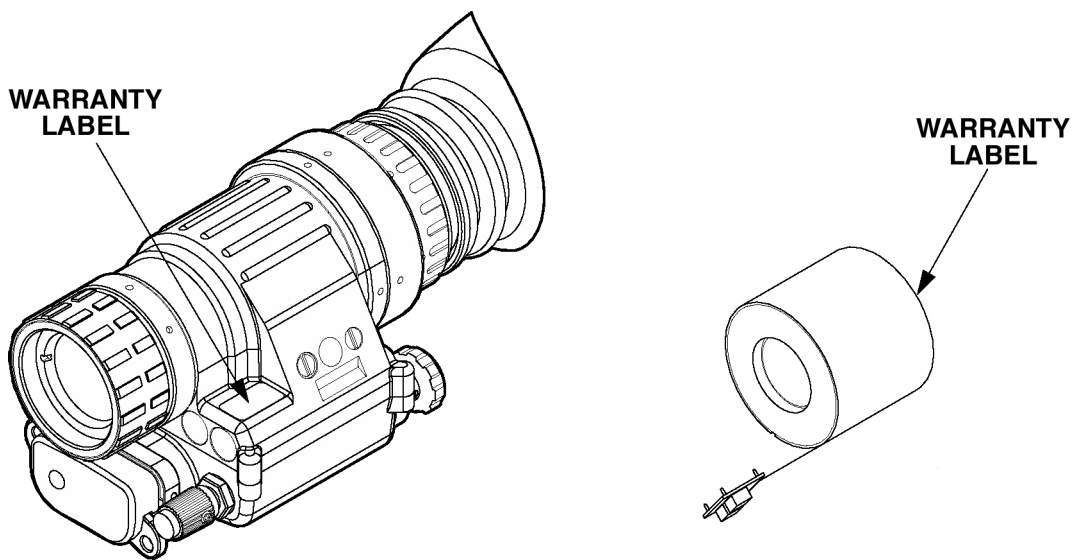

Figure 1-1. Warranty Expiration Label Location.

**1-7 WARRANTY INFORMATION – Continued**

**NOTE**

This warranty does not cover any product that has been subject to misuse, neglect, accident, installation or maintenance in violation of the instructions in the Operator's or Maintenance Technical Manuals. Also, a maintenance testing fee of \$100.00 per image intensifier or \$150.00 per end item will be charged to the appropriate activity for returns which are determined to have no evidence of a defect or have been subjected to misuse, neglect, etc. **Therefore, all PMCS and troubleshooting procedures must be performed before determining that the end item or image intensifier requires warranty action.**

**a. Turn-in Procedures.**

(1) The operator, after completing the PMCS and Troubleshooting, annotates the fault on DA Form 2404 (Army) or OPNAV Form 4790/138 (Navy), completes the appropriate blocks and turns the equipment into the unit maintainer. The unit maintainer will perform all applicable PMCS and Troubleshooting before determining that the end item does not show any faults or must be sent to Direct Support (DS)/Intermediate maintenance for further maintenance actions. If it is determined that the end item needs Intermediate repair, the unit maintainer will annotate DA Form 2407 or the automated system (Army), OPNAV Form 4790/60 (Navy/Marine Corps), and include this form with the end item and send it to appropriate Intermediate maintenance activity. DA Pam 738-750 outlines distribution of copies.

(2) The Direct Support (DS)/Intermediate maintenance activity performs all troubleshooting and maintenance procedures in accordance with the maintenance manual. If a defect is identified and the product is under warranty, per the warranty expiration date on the label, a warranty return is initiated.

**NOTE**

A newly fielded MNVD that fails either the service upon initial receipt of material inspection or fails prior to the expiration of the warranty must be reported on a PQDR, SF 368. This will ensure the unit submitting the PQDR will receive credit for that MNVD. DA Pam 738-750 outlines distribution of copies.

**NOTE**

If using an automated system such as SAMS or ULLS, use the equivalent electronic form, to track using the same procedure as for the hard copy DA Form 2404,2407, or DD Form 314 etc.

**NOTE**

For units operating under SAMS, DA Form 5504 (Maintenance Request) and 5504-1 (Maintenance Request Continuation Sheet) are the only forms used to file warranty claim actions. Do not use SF 368 to report Warranty Claims. DA Pam 738-750 outlines distribution of copies.

**1-7 WARRANTY INFORMATION – Continued**

**NAVY ONLY:** The item should be tagged (e.g. using the DD Form 1577-2). An OPNAV 4790/60, VIDS/MAF shall be filled out which will include the nature of the defect, i.e., spots, flicker, edge glow, etc. and method used to determine type and extent of defect. A product quality deficiency report, message or form SF 368, should be filed for an IN-WARRANTY item to the FST: Commander, Code 805B-Bldg 3291 NAVSURFWARCENDIV, 300 Highway 361, Crane, IN 47522-5001. No defective warranty items are to be shipped directly from the field to a contractor. If there are reoccurring problems for deficient out-of-warranty assemblies, an engineering investigation, in accordance with OPNAVINST 4790.2G, should be forwarded to the FST.

(3) Activities should follow local procedures for shipping equipment to the manufacturer. DD Form 1149 (Requisition and Invoice/Shipping Document) will accompany all shipments to the manufacturer's factory. The manufacturer will prepare a new DD Form 1149 for return shipment to the relevant activity. DA Pam 738-750 outlines distribution of copies.

**b. Return Procedures.** The manufacturer will repair and return all warranted equipment back to designated activities.

To determine the manufacturer of the item, check the identification plate for the manufacturer's (MFR) CAGEC (Commercial and Government Entity Code).

CAGEC	Manufacturer
13567 or 66868	ITT, Roanoke, VA
55311 or 51298	Litton, Tempe, AZ

**OCONUS WARRANTY PROCEDURES ARMY ONLY:**

DS/AVIM will contact one of the following POC's in lieu of contacting the manufacturer for warranty claims.

RSC, Friedrichsfeld, Germany  
POC: Mr. Mike Haase  
DSN 314-375-5348  
[mhaase@hq.amceur.army.mil](mailto:mhaase@hq.amceur.army.mil)

RSC, Korea  
POC: Mr. Harry Footit  
DSN 315-722-3571  
[footith@usfk.korea.army.mil](mailto:footith@usfk.korea.army.mil)

**(1) Voice Media (Telephone).**

(a) For items manufactured by ITT (CAGEC 13567 or 66868): This is accomplished by calling ITT at 1-800-360-6054 during regular business hours 07:30 - 11:30 and 12:30 - 16:30 Eastern Standard (or Daylight Savings) Time, Monday through Friday. During non-business hours, voice mail will be operative which will direct the caller to leave name and complete commercial telephone number including appropriate area code or country/city code and a brief message. ITT will return calls within two business days. Using voice media, ITT may be able to offer on the spot suggestions to help solve a problem. If the problem cannot be resolved over the phone and the product is under warranty, ITT will provide the caller with a Return Authorization (RA) Number and appropriate shipping instructions.



**1-7 WARRANTY INFORMATION – Continued**

(b) For items manufactured by Litton (CAGEC 55311 or 51298): This is accomplished by calling the Litton Customer Service Representative at 1-800-569-8478 during regular business hours 0700 – 1530 Mountain Standard Time, Monday through Friday. The Litton Customer Service Representative can also be reached at 602-303-8956 during regular business hours. During non-business hours, voice mail is available which will direct the caller to leave a name, complete commercial telephone number, to include area code or country and city codes, and a brief message. Litton will return the call within two business days. Using voice media, Litton may be able to offer on-the-spot suggestions to solve a problem. If the problem cannot be addressed over the phone and the product is under warranty, Litton will provide the caller with a Return Goods Authorization (RGA) number and appropriate shipping instructions.

**(2) Electronic Media (E-mail).**

Because of the time zone differences, communication via E-mail may be used by any authorized customer. This procedure can be utilized 24 hours a day with E-mail access. Prepare an E-mail with the following information shown below and send it to:

Date:
Branch of Service:
UIC:
Direct Support/Intermediate Activity:
Address
Point of Contact:
Street and Number:
City:
State/Country:
Zip Code:
Commercial Telephone Number (include area code or country/city code):
Commercial FAX Number (include area code or country/city code):
E-mail Address:
Product Information:
Model:
Serial Number:
Reason for Return:

**Data Required for E-mail and FAX Communication.**

**1-7 WARRANTY INFORMATION – Continued**

(a) For items manufactured by ITT (CAGEC 13567 or 66868): Send a message to ITT at [nvwarranty@nv.de.ittind.com](mailto:nvwarranty@nv.de.ittind.com) via the internet. ITT will answer via a return message providing suggestions to help solve the problem or issue a RA Number.

(b) For items manufactured by Litton (CAGEC 55311 or 51298): Send a message to Litton at [contractscs@littoneos.com](mailto:contractscs@littoneos.com) via the Internet. Litton will respond via a return message providing either a suggestion to solve a specific problem or a RGA number.

**(3) FAX Communication.**

(a) For items manufactured by ITT (CAGEC 13567 or 66868): Send a FAX with the same information as ITT requires for E-mail to ITT at FAX number (540) 366-9015.

(b) For items manufactured by Litton (CAGEC 55311 or 51298): Send a FAX with the same information, as Litton requires for E-mail to Litton at FAX number (602) 966-9055. Litton will provide a response within two business days.

**c Repair Procedures.** The manufacturer will repair and return all warranted equipment back to designated activities. An estimated cost of repair will be provided to the maintenance activity for those items that do not fall within warranty guidelines. The manufacturer will only accept written authorization from authorized personnel at DS/Intermediate maintenance activity prior to conducting repair.

**Things to do to help speed up the return of your equipment:**

1. Review your documents to make sure you have filled in all of the requested information. Your documentation must clearly explain the problem(s) you are having with the equipment.
2. Double check that your return address is legible on all of your documents, as well as, the shipping package.
3. Make sure all of the documents, except your copies, are placed inside of the package before being returned.
4. Write the RA or RGA number on the outside of your package.

**Failure to follow the above guidelines will result in a delay in the return of your equipment.**

## **1-8 CORROSION PREVENTION AND CONTROL (CPC)**

Corrosion prevention and control of electronic material is a continuing concern. It is important that any corrosion problems with this equipment be reported so that the problem can be corrected and improvements made to prevent the problem in future equipment.

While corrosion is typically associated with rusting metal, it can also include deterioration of other materials such as contacts, injection-molded plastic, and foam inserts in the case. Unusual cracking, softening, swelling, or breaking of these other materials may be a corrosion problem.

If a corrosion problem is identified, report it using SF 368, *Product Quality Deficiency Report*. Use keywords such as "corrosion," "rust," "deterioration," or "cracking" to ensure that the information is identified as a CPC problem. Submit the form to the address specified in DA Pam 738-750.

### **Section II. Equipment Description and Data**

## **1-9 EQUIPMENT CHARACTERISTICS, CAPABILITIES AND FEATURES**

### **WARNING**

The IR source is a light that is invisible to the unaided eye for use during conditions of extreme darkness. However, the light from the illuminator can be detected by the enemy using night vision devices.

### **WARNING**

### **EQUIPMENT LIMITATIONS**

To avoid physical and equipment damage when using the MNVD carefully read and understand the following safety precautions.

- The MNVD requires some night light (moonlight, starlight, etc.) to operate. The level of performance depends upon the level of light.
- Night light is reduced by passing cloud cover, while operating under trees, in building shadows, etc.
- The MNVD is less effective viewing into shadows and other darkened areas.
- The MNVD is less effective through rain, fog, sleet, snow or smoke.
- The MNVD will not see through dense smoke.

The MNVD is a hand-held, headmounted, helmet mounted, or weapon mounted night vision system that enables walking, weapon firing, short-range surveillance, map reading, vehicle maintenance, and administering first aid in both moonlight and starlight. Each unit allows for vertical adjustment (by using head strap), fore-and-aft adjustment, objective lens focus, and diopter adjustment. The monocular is also equipped with an IR source, a low-battery indicator and a gain control.

## 1-10 LOCATION AND DESCRIPTION OF MAJOR COMPONENTS

The MNVD includes the items shown in Figure 1-2, sheets 1 and 2. The major components are the monocular, headmount, helmet mount, carrying case and shipping and storage case.

### WARNING

The monocular will not be turned off automatically when flipped up. The monocular must be turned off by the power switch.

**a. Monocular.** The monocular (Figure 1-3) consists of five primary subassemblies: an objective lens, a battery housing, a monocular housing, an image intensifier (not shown), and an eyepiece lens. The battery housing contains a battery cartridge that also acts as a battery cap, power switch and gain control. The monocular also uses the accessories listed below.

(1) Demist Shield - The demist shield (Figure 1-2 sheet 1) is used to prevent the eyepiece lens from becoming fogged.

(2) LIF - The LIF (Figure 1-2 sheet 1) is to be used at all times. For replacing the filter the container is also the wrench. The container/wrench is also used to remove and replace the LIF from the objective lens.

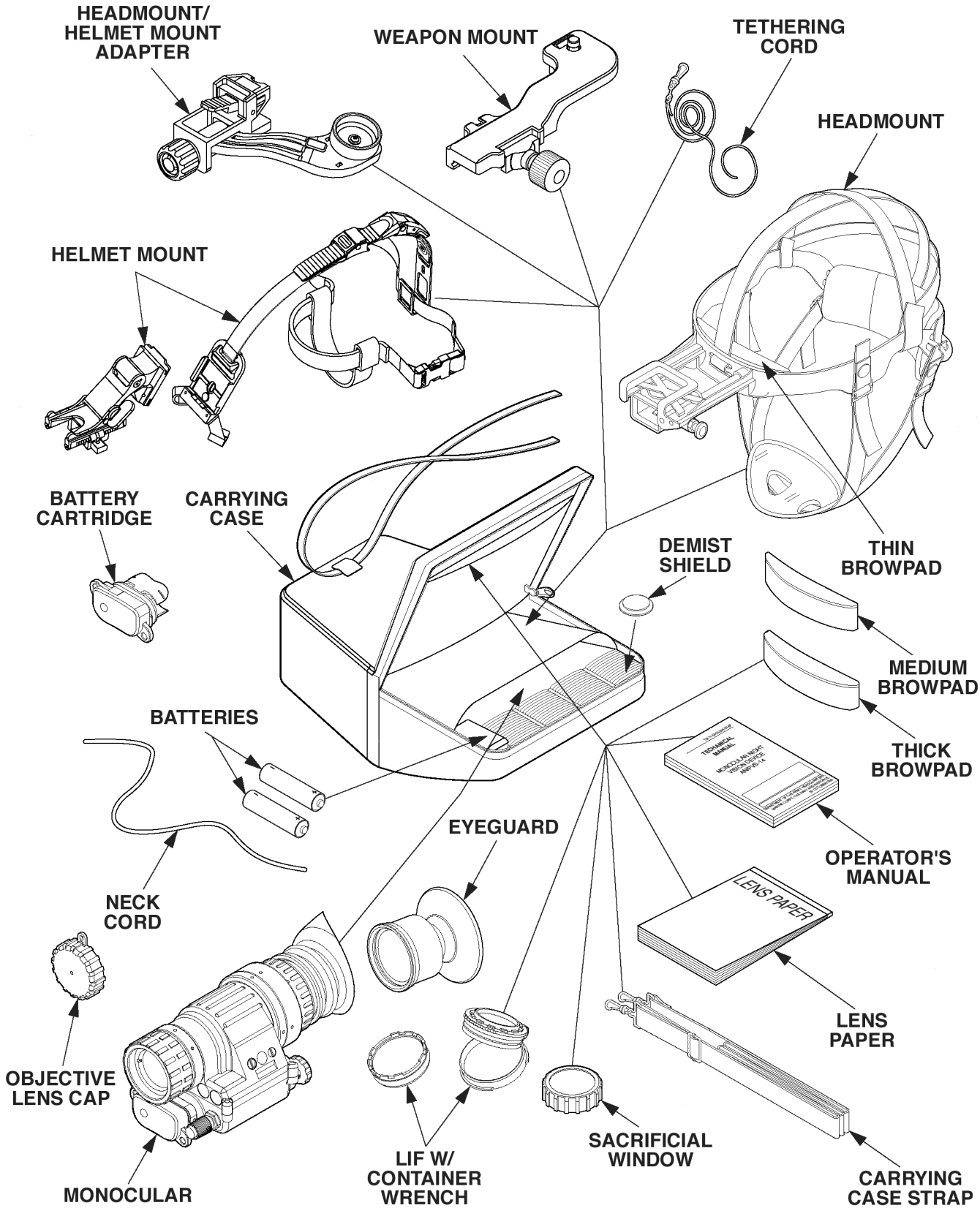

Figure 1-2. Monocular Night Vision Device (MNVD) AN/PVS-14 (Sheet 1 of 2).

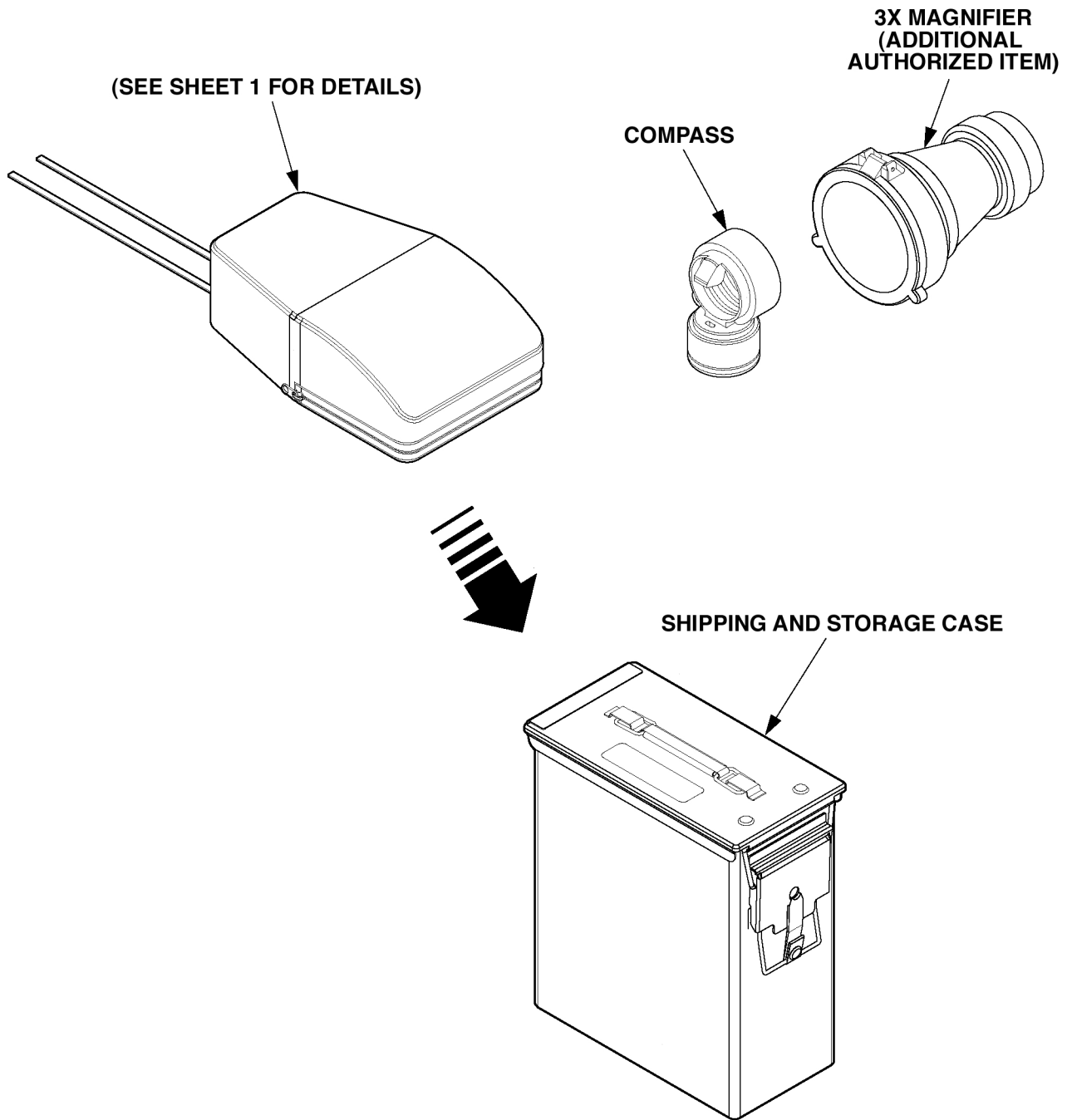
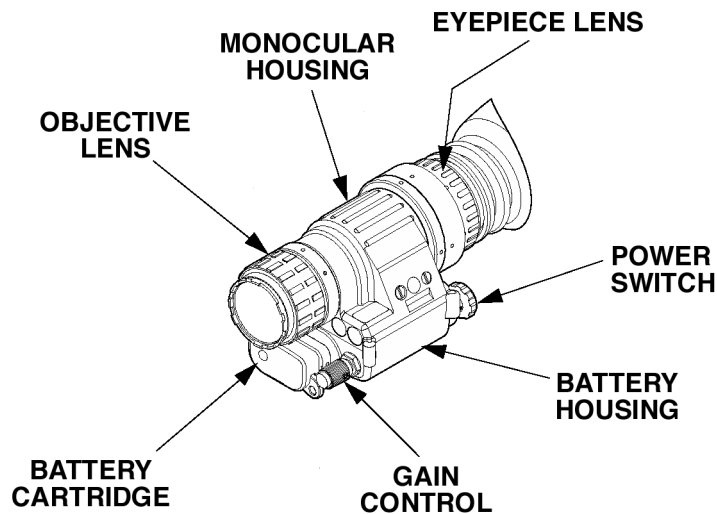

Figure 1-2. Monocular Night Vision Device (MNVD) AN/PVS-14 (Sheet 2 of 2).

**1-10 LOCATION AND DESCRIPTION OF MAJOR COMPONENTS - Continued**



**Figure 1-3. Monocular Night Vision Device (MNVD) AN/PVS-14 and Subassemblies.**

(3) Sacrificial Window - A replaceable sacrificial window (Figure 1-2, sheet 1) is supplied to protect the objective lens during operation in adverse conditions.

(4) Tethering Cord – The tethering cord (Figure 1-2 sheet 1) enables the user to attach the compass or 3X magnifier to a button hole or belt loop to guard against dropping or losing these items.

**WARNING**

The compass illuminator can be seen by others using night vision devices.

(5) Compass - The compass (Figure 1-2, sheet 2) enables the operator to see azimuth readings in the monocular.

(6) 3X Magnifier - (Additional Authorized Item) The 3X magnifier (Figure 1-2, sheet 2) is a lens which can be added to the monocular to extend the operator's observation ranges.

**WARNING**

When installing the headmount over the protective mask, be careful not to break the protective mask seal around your face.

**b. Headmount.** The headmount (Figure 1-2, sheet 1), secures the monocular to the operator's head for night viewing and provides freehand support for use with a weapon, protective mask or other purposes. It is adjustable and cushioned. The thin browpad used for large heads, comes attached to the headmount; the thick and medium browpads, used for smaller heads are stored in the carrying case.

## 1-10 LOCATION AND DESCRIPTION OF MAJOR COMPONENTS - Continued

- c. Helmet Mount.** This item (Figure 1-2, sheet 1), secures the monocular to the Personal Armor System Ground Troops (PASGT) helmet allowing freehand support for use with a weapon, protective mask and/or other purposes. The new helmet mount is made of a ruggedized metal. The old one is made of plastic.
- d. Headmount/Helmet Mount Adapter.** This item (Figure 1-2, sheet 1) is attached to the monocular to allow its use with the headmount or helmet mount. It allows mounting in front of the left or right eye.
- e. Weapon Mount.** The weapon mount (Figure 1-2, sheet 1) adapts the monocular to the receiver rail as configured for the modular weapon system kit.
- f. Carrying Case.** The carrying case (Figure 1-2, sheet 1) is provided for transportation and protection of the monocular, headmount, batteries and accessories. Two slide keepers are provided for belt attachment and three D-rings for shoulder and leg strap attachment. A carrying case strap is also provided which can be attached to the two D-rings on the back of the carrying case.
- g. Shipping and Storage Case.** The MNVD is supplied in a hard shipping and storage case (Figure 1-2, sheet 2).

## 1-11 CONFIGURATION OF IMAGE INTENSIFIER

The image intensifier is cylindrical, with apertures in each end. The aperture on the "front" end has a bluish appearance and is the entrance port for light from the scene, which has been focused through the objective lens. The bluish surface is the photocathode, which converts the input light to electrons inside the intensifier. The aperture on the "rear" end has a light grayish or yellow-grayish appearance and is the exit port for the intensified light from the screen via a twisted fiber optic bundle. The fiber optic re-inverts the inverted image produced by the objective lens, so that the user sees a normal erect image. On the side of the intensifier are two gold-plated contacts that connect to spring contacts in the lower housing of the monocular to provide operating electrical power (2.0 to 3.0 volts) to the intensifier. A flexible circuit emerges from the rear edge of the intensifier. This circuit provides the electrical connection to enable the user to change the intensifier gain by adjusting the gain control on the MNVD. This circuit carries two potentiometers which have been factory-set to establish proper maximum and minimum gain limits. Four pins on the flex circuit mate to four pins on the electronic board in the lower housing of the monocular. On the rear surface of the intensifier is an access hole, normally filled with a soft potting compound, through which the automatic brightness control limit has been factory-set. Along the outer edge of the intensifier is an alignment groove that ends in an alignment notch at the front end. This notch must be aligned to a locator pin in the monocular housing when the intensifier is installed. Otherwise, the intensifier will not fully set in place and the contact may not align properly to power the intensifier.



**1-12 EQUIPMENT DATA**

The following tables provide information pertaining to the operational, electrical, mechanical, optical, and environmental characteristics for the monocular.

**Table 1-2. Operator Adjustment Limits.**

ITEM	LIMITS
Diopter Focus	+2 to -6 diopters
Objective Focus	25 cm to infinity
Variable Gain	±10 to >3,000

**Table 1-3. Electrical Data.**

ITEM	DATA
Power Source Battery Requirements	Battery (1.5 Vdc max each) AA Alkaline (2 required) or AA Lithium L91 (2 required)

**Table 1-4. Mechanical Data.**

ITEM	DATA
Shipping and Storage Case	Size: Approx. 12"L x 14"H x 7"W Weight: Approx. 2 lbs
Carrying Case (Canvas) Monocular (see Note)	Size: Approx. 8"L x 12"H x 4"W Weight: 14 ounces

**NOTE**

Weight of monocular does not include accessories or batteries.

**Table 1-5. Optical Data.**

ITEM	DATA
Magnification	1.0X (3X with 3X magnifier)
Field-of-view	40° (13° with 3X magnifier)
Diopter Adjustment	+2 to -6 diopters
Focus Range	25 cm (9.8") to infinity

**Table 1-6. Environmental Data.**

ITEM	DATA
Monocular Operating Temperature	-51°C to +49°C
Monocular Storage Temperature	-51°C to +85°C
Illumination Required	Overcast starlight to moonlight

Section III. Principles of Operation

**1-13 MECHANICAL FUNCTIONS**

The mechanical functions of the MNVD allow for differences in the physical features of individual operators and provide for operating the system. These functions include power switch, eye relief adjustment, diopter adjustment, gain control and objective lens focus. Mechanical functions are identified in Figure 1-4.

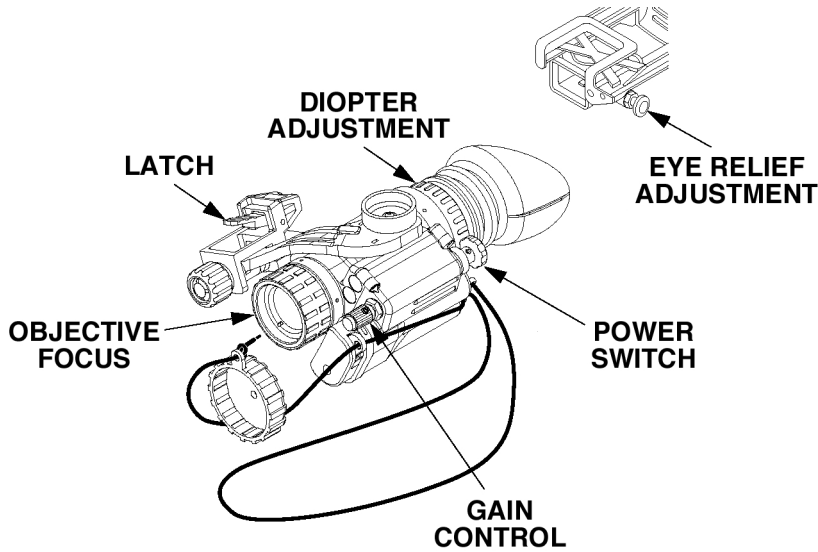

Figure 1-4. Mechanical Functions of the MNVD.

**1-14 OPTICAL FUNCTIONS**

The optical functions include an objective lens, image intensifier, and eyepiece lens (Figure 1-5). The objective lens collects light reflected from the night scene by the moon, stars, or night sky, inverts the image and focuses that image on the image intensifier. The image intensifier converts the captured light into a visible image and re-inverts the image, which can then be viewed through the eyepiece.

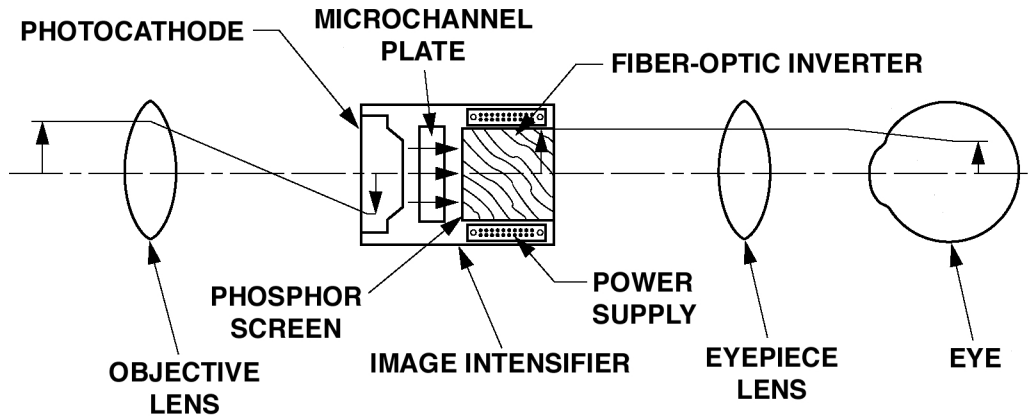

Figure 1-5. MNVD Optical Function Diagram.

## 1-15 ELECTRONIC CIRCUIT FUNCTIONS

The electronic circuit (Figure 1-6) regulates the direct-current voltage from the batteries to the image intensifier, gain control and IR source as required. It also monitors the output voltage of the batteries and turns on a low-battery indicator when the available battery voltage is 1.9 - 2.1 Vdc.

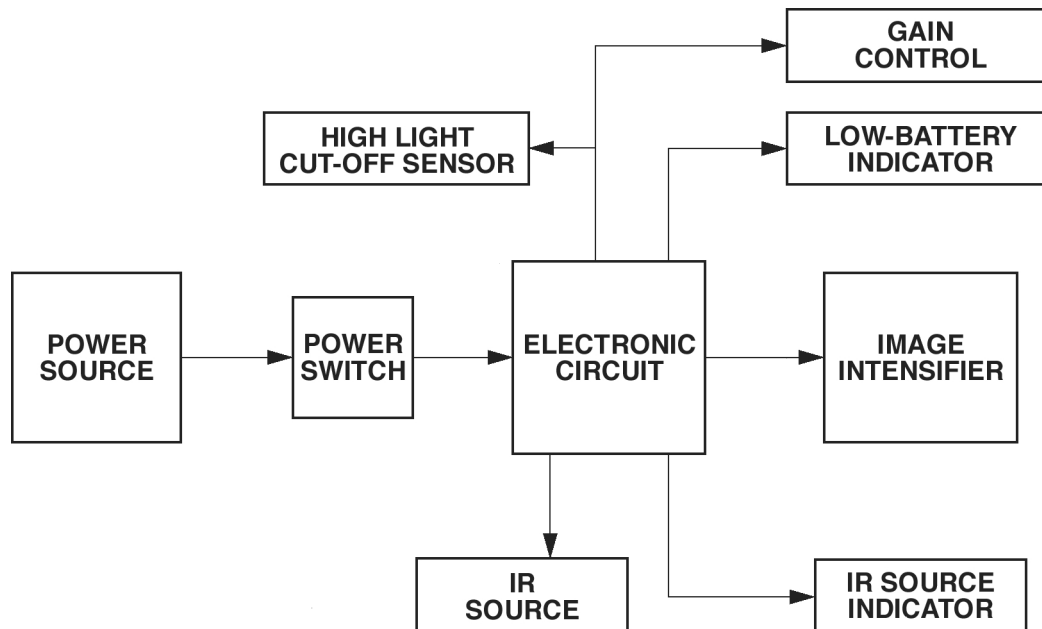

Figure 1-6. Electrical Function of MNVD.

- a. **Power Source.** The electronic circuit is powered by batteries.
- b. **Electrical Function.** Power from the batteries is supplied to the components through the power switch as follows:

RESET/OFF Position - With the power switch in the OFF position, the circuit is not energized for either the image intensifier, gain control, low-battery or the IR source. Also, turn the power switch to this position to reset after high light cut-off.

ON Position - Power is drawn from the battery compartment to energize the monocular. When the voltage drops to between 1.9 and 2.1 Vdc, a low-battery indicator in the eyepiece blinks indicating approximately 30 minutes of operating time remaining.

IR/PULL Position - Power is drawn from the battery compartment to energize the monocular and IR light source and a steady red indicator IR light in the eyepiece.

- c. **High Light Cut-off.** The monocular will automatically cut off after  $70 \pm 30$  seconds of operation in daylight or bright room light. Individual bright lights (headlights, flashlights, or other concentrated light sources) will not actuate the high light detector located on the front of the monocular. To turn monocular back ON, turn power switch to RESET/OFF position and then to ON again.

## CHAPTER 2 UNIT MAINTENANCE INSTRUCTIONS

---

	<u>Page</u>
Overview .....	2-1
Common Tools and Equipment .....	2-2
Special Tools, TMDE, and Support Equipment.....	2-2
Repair Parts .....	2-2
Site and Shelter Requirements.....	2-2
Service Upon Receipt of Material .....	2-2
Installation.....	2-3
Preventive Maintenance Checks and Services (PMCS) Table .....	2-3
Image Intensifier Inspection Criteria .....	2-3
Unit Troubleshooting .....	2-3
Resolution Check Using TS-4348/UV Test Set.....	2-3
Removal and Installation of Components .....	2-4
Removal and Installation of Power Switch Knob.....	2-4
Removal and Installation of Gain Control Knob .....	2-5
Removal and Installation of Batteries/Battery Cartridge.....	2-5
Removal and Installation of Browpads .....	2-6
Removal and Installation of Neck Pads .....	2-6
Removal and Installation of Chinstrap .....	2-8
Removal and Installation of Cross Strap.....	2-9
Removal and Installation of Helmet Mount .....	2-10
Removal and Installation of Magnet on Metal Helmet Mount.....	2-11
Repainting and Refinishing Requirements.....	2-12
Lubrication Requirements .....	2-12
Packing the MNVD.....	2-12

### **OVERVIEW**

This chapter contains maintenance procedures that are the responsibility of Unit Maintenance. Operation instructions and operator maintenance can be found in TM 11-5855-306-10, Operator's Manual for Monocular Night Vision Device (MNVD), AN/PVS-14, and are not repeated in this chapter.

The Unit level tasks include routine inspections, cleaning, visual inspection of image intensifier performance, resolution test using TS-4348/UV test set, and repair by removing and replacing LIF, neck cord, eyecup/eyeguard, lens cover, weapon mount, compass, demist shield, sacrificial window, carrying case, head mount/helmet mount adapter, headmount, helmet mount, power switch knob, gain control knob, batteries/battery cartridge, browpads, neck pads, chinstrap, cross-strap, helmet mount, and magnet on metal helmet mount.

## Section I. Repair Parts, Tools, Special Tools, TMDE, and Support Equipment

### **2-1 COMMON TOOLS AND EQUIPMENT**

For authorized common tools and equipment, refer to the Modified Table of Organization and Equipment (MTOE, CTA 50-970, or CTA 8-100), as applicable to your unit.

### **2-2 SPECIAL TOOLS, TMDE, AND SUPPORT EQUIPMENT**

Refer to Appendix B for the Maintenance Allocation Chart (MAC) for authorized maintenance and to Appendix C for Repair Parts and Special Tools List (RPSTL) for information on special tools, Test, Measurement, and Diagnostic Equipment (TMDE), and support equipment required at unit maintenance. In addition, instructions for a fabricated black spot test fixture are contained in Appendix E.

### **2-3 REPAIR PARTS**

Repair parts are listed and illustrated in Appendix C of this manual.

## Section II. Service Upon Receipt

### **2-4 SITE AND SHELTER REQUIREMENTS**

The check and service functions, as prescribed herein, should be accomplished in the electronic repair service area. A standard electronic workbench provides an adequate working area for MNVD maintenance requirements. The surface area should be free of chemicals, vapors, and emissions that may damage external parts of the MNVD. Normal sheltering from the elements (cold, rain, dust, etc.) is necessary. There should be provisions to perform certain service functions and specified tests in a dark room or dark area in which all places where light can enter (e.g., windows, doors, wall and ceiling joints) have been blocked. This blocking can be accomplished using either permanent or temporary shields such as tape or heavy curtains. The room or area should appear dark (without the evidence of light entering the area) to your unaided eye after approximately 10 minutes of dark adaptation. Use a night vision device to identify and isolate the place where light enters.

### **2-5 SERVICE UPON RECEIPT OF MATERIAL**

#### **CAUTION**

The monocular is a precision electro-optical instrument and must be handled carefully at all times to prevent damage.

(1) Inspect the MNVD for possible damage incurred during shipment. If the MNVD has been damaged, report the damage on SF 364, Report of Discrepancy.

**2-5 SERVICE UPON RECEIPT OF MATERIAL – Continued**

(2) Check the MNVD against the packing slip to see if the shipment is complete. Report all discrepancies in accordance with the instructions of DA Pam 738-750. Marine Corps personnel refer to MCO P4610.19, Reporting of Transportation Discrepancies in Shipments.

(3) Refer to DA Pam 25-30, Consolidated Index of Army Publications and Blank Forms, to determine whether there are modification work orders (MWOs) pertaining to the MNVD. Marine Corps Personnel refer to the on-line MCPDS Index of Technical Publications.

(4) Upon receipt of a newly fielded monocular, fill out a hard copy DD Form 314 (IAW DA PAM 738-750) for that system. The first 180 day service is penned in using the warranty date minus 30 months, then pencil in when the next 180 day service is due. All used monoculars received by the unit must have a 180 day service performed. If using an automated system such as SAMS or ULLS, use the equivalent electronic form, to track using the same procedure as for the hard copy DD Form 314.

**2-6 INSTALLATION**

Installation instructions are contained in TM 11-5855-306-10, Operator's Manual for Monocular Night Vision Device (MNVD), AN/PVS-14.

**Section III. Preventive Maintenance Checks and Services**

**2-7 PREVENTIVE MAINTENANCE CHECKS AND SERVICES (PMCS) TABLE**

Preventive maintenance checks and services are contained in TM 11-5855-306-10, Operator's Manual for Monocular Night Vision Device (MNVD), AN/PVS-14.

**2-8 IMAGE INTENSIFIER INSPECTION CRITERIA**

Inspection criteria for proper image intensifier operations are contained in TM 11-5855-306-10, Operator's Manual for Monocular Night Vision Device (MNVD), AN/PVS-14.

**Section IV. Unit Troubleshooting**

**2-9 UNIT TROUBLESHOOTING**

Troubleshooting procedures are contained in TM 11-5855-306-10, Operator's Manual for Monocular Night Vision Device (MNVD), AN/PVS-14.

**2-10 RESOLUTION CHECK USING TS-4348/UV TEST SET**

Resolution check using TS-4348/UV test set is contained in TM 11-5855-306-10, Operator's Manual for Monocular Night Vision Device (MNVD), AN/PVS-14.

## **Section V. Unit Maintenance Procedures**

The following components of the MNVD Monocular Night Vision Device are authorized for removal and replacement at the unit level.

### **2-11 REMOVAL AND INSTALLATION OF COMPONENTS**

The procedures for removal and installation of the following items can be found in TM 11-5855-306-10, Operator's Manual, Monocular Night Vision Device (MNVD), AN/PVS-14.

- a. LIF
- b. Neck Cord
- c. Eyecup/Eyeguard
- d. Lens Cover
- e. Weapon Mount
- f. Compass
- g. Demist Shield
- h. Sacrificial Window
- i. Carrying Case
- j. Headmount/Helmet Mount Adapter
- k. Headmount
- l. Helmet Mount

### **2-12 REMOVAL AND INSTALLATION OF POWER SWITCH KNOB**

The power switch knob can be replaced without disturbing any of the monocular's assemblies. One lock pin secures the knob to the shaft.

---

#### **INITIAL SETUP**

##### Test Facility

Standard workbench in the electronic repair service area

##### Tools

Hex wrench .050"

##### Materials/Parts

Power Switch Knob, (Appendix C, Figure C-2, Item 11)

---

#### **REMOVAL**

- (1) With the .050" hex wrench, unthread knob lock pin counterclockwise.
- (2) Remove knob lock pin and remove knob (Figure 1-3).

## 2-12 REMOVAL AND INSTALLATION OF POWER SWITCH KNOB-Continued

### INSTALLATION

- (1) Position knob on switch shaft. Align lock pinhole in knob with lock pinhole in shaft.
- (2) Insert lock pin into knob and use the .050" hex wrench to tighten lock pin hand tight.

## 2-13 REMOVAL AND INSTALLATION OF GAIN CONTROL KNOB

Inspect gain control knob (Figure 1-3), which may be loose, missing, or broken.

### INITIAL SETUP

#### Test Facility

Standard workbench in the electronic repair service area

#### Tools

Hex wrench .050"

#### Materials/Parts

Gain Control Knob (Appendix C, Figure C-2, Item 14)

### REMOVAL

- (1) With .050" hex wrench, loosen the two setscrews located on the side of the knob.
- (2) Remove the gain control knob.

### INSTALLATION

- (1) Position the gain control knob on potentiometer shaft.
- (2) Use .050" hex wrench to tighten the two setscrews hand tight.

## 2-14 REMOVAL AND INSTALLATION OF BATTERIES/BATTERY CARTRIDGE

### WARNING

Do not carry batteries in pockets containing metal objects such as coins, keys, etc. Metal objects can cause batteries to short circuit and become very hot.



## **2-14 REMOVAL AND INSTALLATION OF BATTERIES/BATTERY CARTRIDGE - Continued**

Batteries are replaced by user per TM 11-5855-306-10, Operator's Manual, Monocular Night Vision Device (MNVD), AN/PVS-14.

Inspect battery cartridge and O-ring for damage or loss. Replace battery cartridge or O-ring if damaged or missing.

### **INITIAL SETUP**

#### Test Facility

Standard workbench in the electronic repair service area

#### Tools

None

#### Materials/Parts

Battery cartridge (Appendix C, Figure C-2, Item 16 )

O-ring (Appendix C, Figure C-2, Item 15)

Lubricant (Silicone Grease) (Appendix D, Item 2)

### **REMOVAL**

- (1) Remove battery cartridge (Figure 1-3) by squeezing the two tabs together and pulling out.

### **INSTALLATION**

- (1) Apply a light coating of lubricant on the O-ring before inserting it into the groove in the battery cartridge.

- (2) Replace battery cartridge by pushing cartridge at pressure points into the housing, making sure both latches on either side are engaged. You will feel them click into place.

## **2-15 REMOVAL AND INSTALLATION OF BROWPADS**

- (1) Remove old browpad (Figure 2-1) by grasping the headband and peeling off the old browpad.

- (2) Replace browpad by gently pressing on the new browpad and smoothing out any wrinkles in new browpad.

## **2-16 REMOVAL AND INSTALLATION OF NECK PADS**

- (1) Remove vertical adjustment strap (Figure 2-1) from sliding bar buckle at rear of neck pad.

- (2) Remove right chinstrap from sliding bar buckle on right side of neck pad. Remove left snap from left side of neck pad.

**2-16 REMOVAL AND INSTALLATION OF NECK PADS – Continued**

- (3) Unlace neck pad straps (Figure 2-2) from strap retaining tabs in headband (Figure 2-1).
- (4) Replace neck pad by lacing straps as shown in Figure 2-2. Lift upper strap retention tab to allow neck pad strap to be inserted into fastener area.

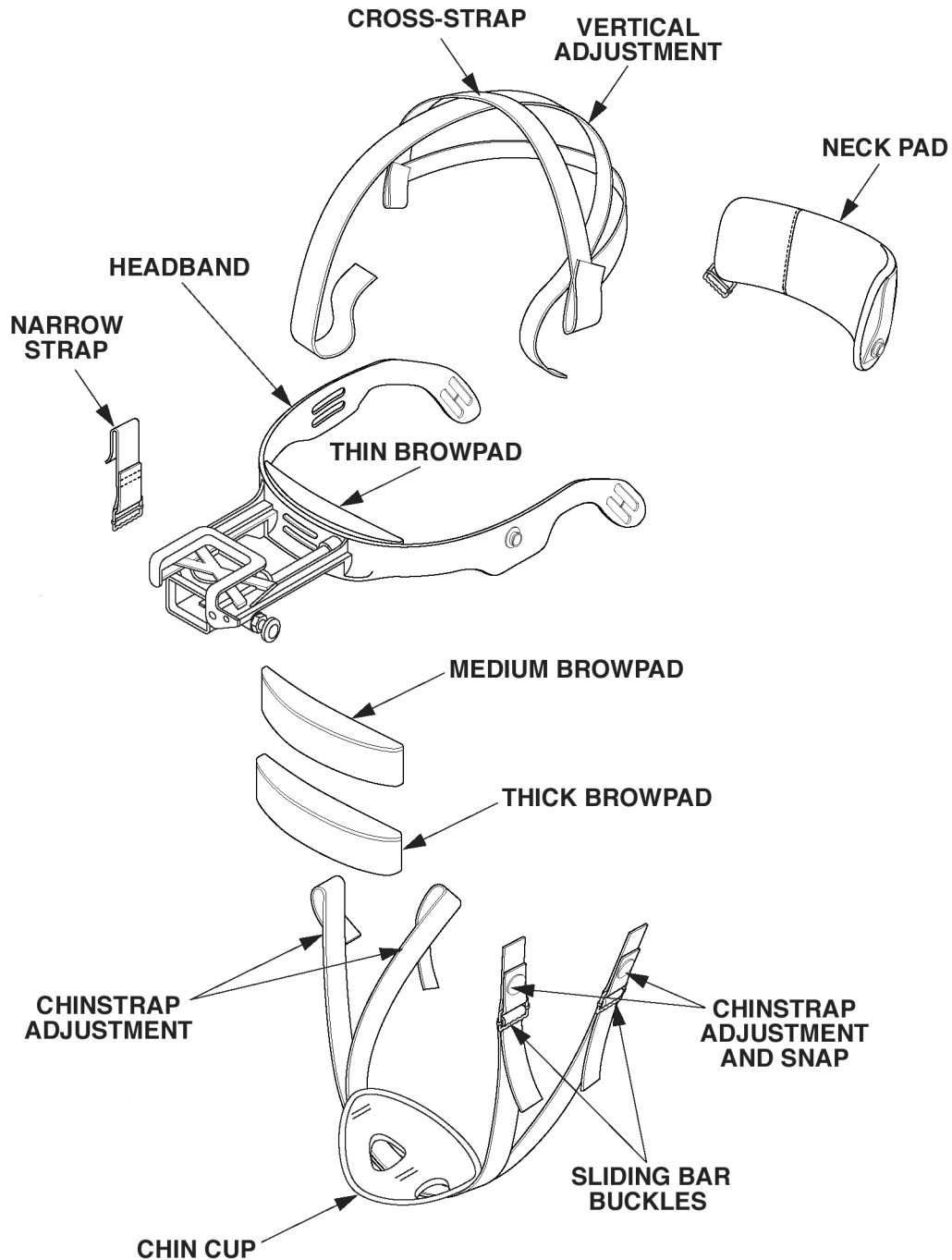

**Figure 2-1. Headmount Components Removal and Installation.**

**2-16 REMOVAL AND INSTALLATION OF NECK PADS - Continued**

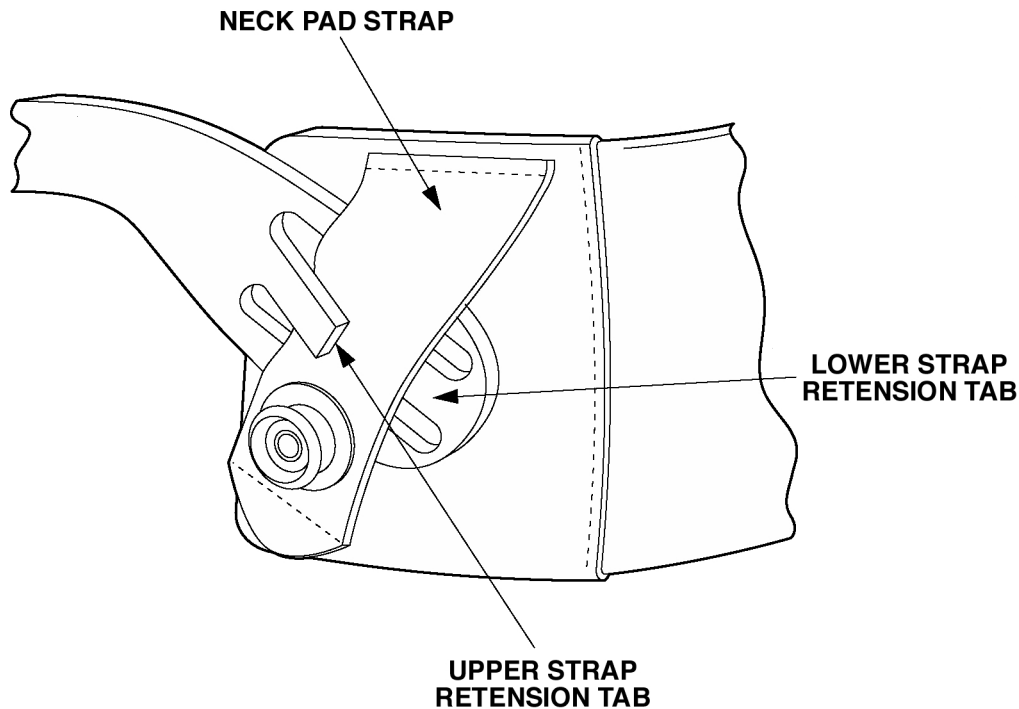

**Figure 2-2. Lacing of Right and Left Neck Pad Straps.**

- (5) Slip neck pad strap under upper strap retention tab. Straighten strap, pulling strap under lower strap retention tab.
- (6) Repeat steps 4 and 5 for the other side of neck pad and headband.

**2-17 REMOVAL AND INSTALLATION OF CHINSTRAP**

- (1) Remove chinstrap (Figure 2-1) by unsnapping the two snaps from the left side of the headband and neck pad. Unbuckle the chinstraps from narrow strap and right side of neck pad.
- (2) Replace the chinstrap by installing two snaps on the left side of the headband and neck pad. Lace the two right straps into their respective sliding bar buckles on the right side of the headband and neck pad. (Figure 2-3)

**2-17 REMOVAL AND INSTALLATION OF CHINSTRAP - Continued**

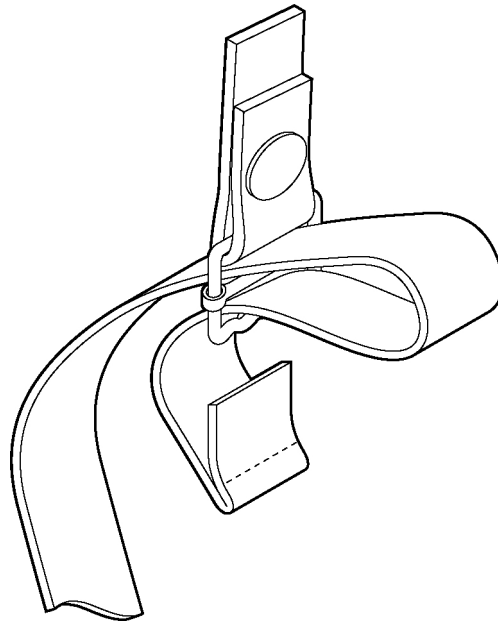

**Figure 2-3. Lacing of Sliding Bar Buckles.**

**2-18 REMOVAL AND INSTALLATION OF CROSS STRAP**

- (1) Remove browpad (para 2-15.)
- (2) Remove neck pad (para 2-16.)
- (3) Remove cross-strap front strap from headband (Figure 2-1) by unthreading strap from headband slots.
- (4) Slide strap free of headband by sliding left and right strap loops off at rear of headmount.

**NOTE**

The elastic straps should be on top of the vertical adjustment strap when headmount is properly installed.

- (5) Replace cross-strap by installing left and right strap loops onto headband. Thread cross-strap front strap through front top headband slot from inside headband. Pull strap out and thread back through bottom slot.

**2-18 REMOVAL AND INSTALLATION OF CROSS STRAP - Continued**

- (6) Replace neck pad (para 2-16.)
- (7) Attach chinstrap right rear strap to right sliding bar buckle on neck pad.
- (8) Refer to Figure 2-3 for correct lacing. Attach chinstrap (Figure 2-1) left rear snap to mating fastener on neck pad.
- (9) Attach cross-strap vertical adjustment strap into mating sliding bar buckle attached to center outside of neck pad.
- (10) Replace browpad (para 2-15.)

**2-19 REMOVAL AND INSTALLATION OF HELMET MOUNT**

- (1) Press the release (Figure 2-4) to remove the mount from the helmet mount bracket.
- (2) Replace the helmet mount by inserting the top edge of the helmet mount under the keeper on the helmet mount bracket and rotate downward until the latch engages.

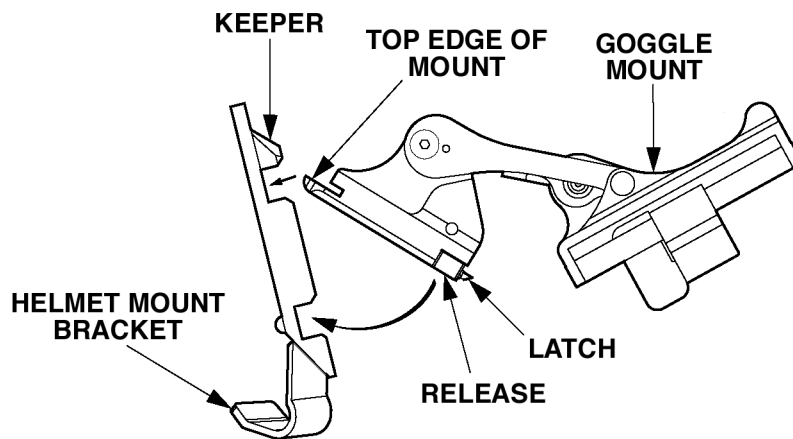

**Figure 2-4. Installation of Helmet Mount.**

## 2-20 REMOVAL AND INSTALLATION OF MAGNET ON METAL HELMET MOUNT

### INITIAL SETUP

#### Test Facility

Standard workbench in the electronic repair service area

#### Tools

Hex wrench 5/64-in.

#### Materials/Parts

None

### REMOVAL

- (1) With 5/64-in. hex wrench, remove the two screws located behind the socket.
- (2) Remove the magnet on the metal helmet mount.
- (3) Removed magnet should be placed in case for storage.

### INSTALLATION

- (1) Position the magnet by aligning with the holes in the metal helmet mount and insert the two screws. (Figure 2-5.)
- (2) Use 5/64-in. hex wrench to tighten the two screws hand tight.

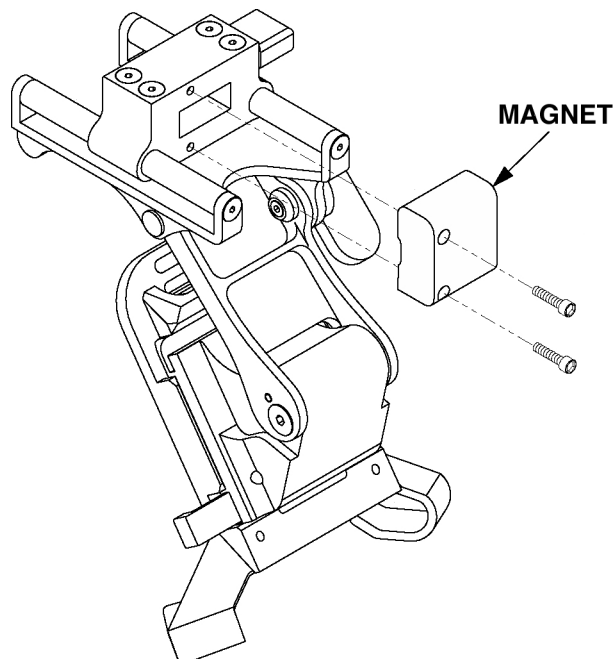

Figure 2-5. Magnet, Metal Helmet Mount.

## **2-21 REPAINTING AND REFINISHING REQUIREMENTS**

Unit maintenance personnel are not authorized or required to repaint or refinish any component of monocular, accessories, carrying case or shipping and storage case.

## **2-22 LUBRICATION REQUIREMENTS**

The only lubrication authorized at this level is lubrication of the battery cartridge O-ring (Appendix D, Item 2).

# **Section VI. Preparation for Storage and Shipment**

## **2-23 PACKING THE MNVD**

(1) Remove any batteries that may be in the battery compartment and replace the battery cartridge. Do not store the monocular with batteries installed.

(2) Replace lens covers on the objective lens and eyepiece lens. Insert the monocular, objective lens end first, into the carrying case.

### **NOTE**

Before returning the monocular or any component to the carrying case, make sure it and the carrying case are free of dirt, dust, and moisture.

(3) Make sure the monocular and accessories are stored in the appropriate locations in the carrying case (Figure 1-2, sheet 1) and close the case.

(4) Return the carrying case to the proper location in the shipping and storage case and close the cover. Make sure all fasteners on the outside of shipping and storage case are secured.

## CHAPTER 3 DIRECT SUPPORT MAINTENANCE INSTRUCTIONS

---

	<u>Page</u>
Overview .....	3-1
Common Tools and Equipment .....	3-1
Special Tools, TMDE and Support Equipment.....	3-2
Repair Parts .....	3-2
Site and Shelter Requirements .....	3-2
Service Upon Receipt of Material .....	3-2
Scope .....	3-3
Direct Support Troubleshooting .....	3-3
TS-3895A/UV Preparation for Use.....	3-7
Testing Resolution Using TS-3895A/UV .....	3-7
Electrical Troubleshooting .....	3-13
Black Spot Check .....	3-14
Removal, Repair, and Replacement of Eyepiece Lens .....	3-20
Setting Zero Diopter for Eyepiece.....	3-29
Removal and Installation of Battery Housing .....	3-34
Removal and Installation of Image Intensifier .....	3-39
Removal and Installation of Objective Lens .....	3-43
Objective Lens Infinity Focus Setting.....	3-47
Removal and Installation of Monocular Housing .....	3-49
Purging.....	3-50
Operational Checks .....	3-54
Packing the MNVD .....	3-54
Shipping the Image Intensifier .....	3-54

### **OVERVIEW**

Direct support maintenance personnel are authorized by the Maintenance Allocation Chart (MAC) to perform inspection, repair, and replacement procedures to return the monocular to operational status.

#### **Section I. Repair Parts, Tools, Special Tools, TMDE, and Support Equipment**

### **3-1 COMMON TOOLS AND EQUIPMENT**

For authorized common tools and equipment, refer to the Modified Table of Organization and Equipment (MTOE), CTA 50-970, or CTA-8-100, as applicable to your unit.



### **3-2 SPECIAL TOOLS, TMDE, AND SUPPORT EQUIPMENT**

Refer to Appendix B for the Maintenance Allocation Chart (MAC) and to Appendix C for Repair Parts and Special Tools List (RPSTL) for information on special tools, Test, Measurement, and Diagnostic Equipment (TMDE), and support equipment required at the Direct Support Maintenance. In addition, instructions for a fabricated black spot text fixture are contained in Appendix E.

### **3-3 REPAIR PARTS**

Repair parts required by Direct Support Maintenance to maintain the MNVD are listed and illustrated in Appendix C.

## **Section II. Service Upon Receipt**

### **3-4 SITE AND SHELTER REQUIREMENTS**

Direct Support maintenance requirements for site and shelter are the same as those specified in paragraph 2-4 with the additional requirement of a clean station. The clean station is an area that is dirt-free and environmentally controlled for temperature and humidity, such as a bench top, where you can repair and service the battery housing of the monocular. Because the clean station is where the battery housing is opened, exposing the inside lens surfaces and the optics of the image intensifier, it must be free of debris or any other material that can enter a disassembled system and contaminate it. The clean station does not require a flow hood.

### **3-5 SERVICE UPON RECEIPT OF MATERIAL**

Requirements for inspecting equipment are the same as those for Unit Maintenance. Refer to TM 11-5855-306-10, Operator's Manual, Monocular Night Vision Device (MNVD), AN/PVS-14.

### Section III. Direct Support Servicing

#### 3-6 SCOPE

#### NOTE

The TS-4348/UV Test Set can be used for the 180 day service PASS/FAIL resolution testing. When an image intensifier FAILS the resolution test using the TS-4348/UV Test Set, the system must be rechecked using the TS-3895A/UV Test Set. The TS-3895A/UV Test Set determines the final outcome of the image intensifier being tested.

Before a monocular is placed into use, it must receive the 180-day service if it is not a newly fielded system. A 180-day service is performed on the monocular by the Direct Support. This 180-day service consists of a PMCS, purging and a resolution test (using the TS-4348/UV or TS-3895A/UV). If a system Passes the resolution testing, no faults found during PMCS and is purged, then the monocular has met all requirements for the 180-day service using either test set. Refer to paragraph 2-7 for the PMCS checks. Instructions for the other servicing requirements are contained in this section.

#### 180 Day Servicing.

- a. **PMCS** - Refer to TM 11-5855-306-10, Operator's Manual, Monocular Night Vision Device (MNVD), AN/PVS-14.
- b. **Purging** -(para 3-19.)
- c. **Resolution Test** - For TS-4348/UV, refer to TM 11-5855-306-10, Operator's Manual, Monocular Night Vision Device (MNVD), AN/PVS-14. For TS-3895A/UV, (para 3-9.)

### Section IV. Direct Support Troubleshooting

#### 3-7 DIRECT SUPPORT TROUBLESHOOTING

#### CAUTION

Maintenance for the MNVD should be performed in an environment that is as dust free as possible to protect optical assemblies and image intensifier.

- a. **Purpose of Troubleshooting.** Troubleshooting is required to isolate and identify defective assemblies in the MNVD. Troubleshooting consists of performing inspections and operational checks to determine the symptom of the malfunction. The direct support troubleshooting table is then used to determine the probable cause, further troubleshooting instructions, and the required corrective action. Image intensifier malfunctions can be determined by using TS-3895A/UV test set to assess image intensifier and resolution at high and low-illumination levels. Electrical troubleshooting consists of using a standard multimeter to determine failures in the battery housing, which could result in lack of power to the image intensifier.

**3-7 DIRECT SUPPORT TROUBLESHOOTING – Continued**

**b. Direct Support of Troubleshooting.** Table 3-1 is to be used as a guide for systematic and efficient procedures to isolate malfunctions in the monocular. This table cannot list all the malfunctions that may occur, all the tests and inspections needed to find the fault, or all the corrective actions needed to correct the fault. If equipment malfunction is not listed or actions listed do not correct the fault, notify your supervisor.

**CAUTION**

Before proceeding with any corrective action, confirm that the monocular or image intensifier is out of the warranty period. Failure to utilize warranty coverage will result in excess charges to the unit. (para 1-7).

**Table 3-1. Troubleshooting.**

PROBLEM	PROBABLE CAUSE	CORRECTIVE ACTION
No green glow observed in eyepiece (image intensifier not illuminated).	Batteries dead, or battery cartridge damaged.  Defective image intensifier or battery housing.	Replace batteries or battery cartridge (para 2-14)  Perform electrical troubleshooting Procedure (para 3-10.)
IR illumination source not operative.	Defective battery housing.	Replace battery housing (para 3-14.).
IR illumination indicator light not operative.	Defective light pipe in eyepiece.  Defective battery housing.	Replace light pipe (para 3-15.)  Replace battery housing (para 3-14.).
Defective low-battery detection capability.	Defective light pipe in eyepiece.  Defective battery housing.	Replace light pipe (para 3-15)  Replace battery housing (para 3-14.).
Image not clear.	Dirty lens.  Eyepiece out of focus.  Objective lens out of focus.	Clean the objective and eyepiece lens of monocular by using isopropyl alcohol and cotton-tipped applicators. Moisten applicator with alcohol and use circular motions beginning at the center of the lenses and moving in larger circles to the outside of the lenses. Reset (para 3-13).  Refocus eyepiece.  Refocus objective lens. Reset (para 3-17.)

**3-7 DIRECT SUPPORT TROUBLESHOOTING – Continued**

**Table 3-1. Troubleshooting - Continued.**

PROBLEM	PROBABLE CAUSE	CORRECTIVE ACTION
Image not clear. Cont'd.	Moisture in lenses.	Inspect for cracked housing or defective O-rings. Replace defective parts and purge monocular (para 3-19)  If no damaged parts are found, clean optics and purge monocular to remove moisture (para 3-19)
	Optical system damaged.	Inspect eyepiece and Objective lens. Replace defective eyepiece lens (para 3-12) or objective lens (para 3-16).
Image will not focus at or Near infinity.	Objective infinity focus not adjusted.	Perform objective lens infinity focus adjustment (para 3-17).
Diopter adjustment cannot be made.	Defective eyepiece.	Replace eyepiece (para 3-12).
Monocular fails resolution test.	Objective infinity focus not properly set.	Set objective infinity focus (para 3-17)
	Eyepiece out of focus.	Refocus eyepiece. Set diopter (para 3-13).
	Optical system damaged.	Inspect eyepiece and objective lens. Replace defective eyepiece lens (para 3-12) or objective lens (para 3-16).
	Moisture in main housing.	Inspect for cracked housing or defective O-rings. Replace defective parts and purge monocular (para 3-19).

**3-7 DIRECT SUPPORT TROUBLESHOOTING – Continued**

**Table 3-1. Troubleshooting - Continued.**

PROBLEM	PROBABLE CAUSE	CORRECTIVE ACTION
Monocular fails resolution test Cont'd.	Defective image intensifier.	Replace image intensifier (para 3-15).
Monocular does not cut off within 70 ±30 seconds in daylight or bright room light. Do not use fluorescent lighting.	Defective battery housing.	Replace battery housing (para 3-14).

**3-8 TS-3895A/UV PREPARATION FOR USE**

Use TM 11-5855-264-14, Operator's, Unit, Direct Support and General Support Maintenance Manual for TS-3895A/UV test sets, to set up the test set and perform self-test.

**NOTE**

Before using the TS-3895A/UV, refer to TM 11-5855-264-14, to familiarize yourself with the operation, warnings, and cautions associated with that test equipment.

**3-9 TESTING RESOLUTION USING TS-3895A/UV**

**NOTE**

The TS-4348/UV does have the capability of testing resolution (refer to TM 11-5855-306-10).

### 3-9 TESTING RESOLUTION USING TS-3895A/UV – Continued

---

#### INITIAL SETUP

Test Facility

Clean station in the electronic repair service area.

Tools

None

Equipment

TS-3895A/UV (Appendix B, Item 2)

Materials/Parts

Cotton-tipped applicators (Appendix D, Item 10)  
Isopropyl alcohol (Appendix D, Item 1)

---

#### PROCEDURE

- (1) Unpack monocular and test set.
- (2) Clean objective and eyepiece lens of monocular with cotton-tipped applicators and isopropyl alcohol.
- (3) Review the location of major components (Figure 3-1).
- (4) Ensure that test port lenses of test set are clean and free of dirt.
- (5) Attach the large goggle adapter to either test port and cover remaining test port.
- (6) Attach monocular to test set by inserting the objective lens into the adapter (Figure 3-2).

**3-9 TESTING RESOLUTION USING TS-3895A/UV – Continued**

**LOW LIGHT TUBE RESOLUTION TEST**

**NOTE**

- The following test must be performed in a darkened area. Your eyes must be dark-adapted to perform this test. It takes a minimum of 10 minutes to become properly dark-adapted for low light resolution evaluation. However, if you have just been exposed to bright sunlight, dark adaptation will take longer.
- Do not reject monocular for resolution unless your eyes have been adequately dark-adapted.
- Review the following test procedure before entering the darkened area.

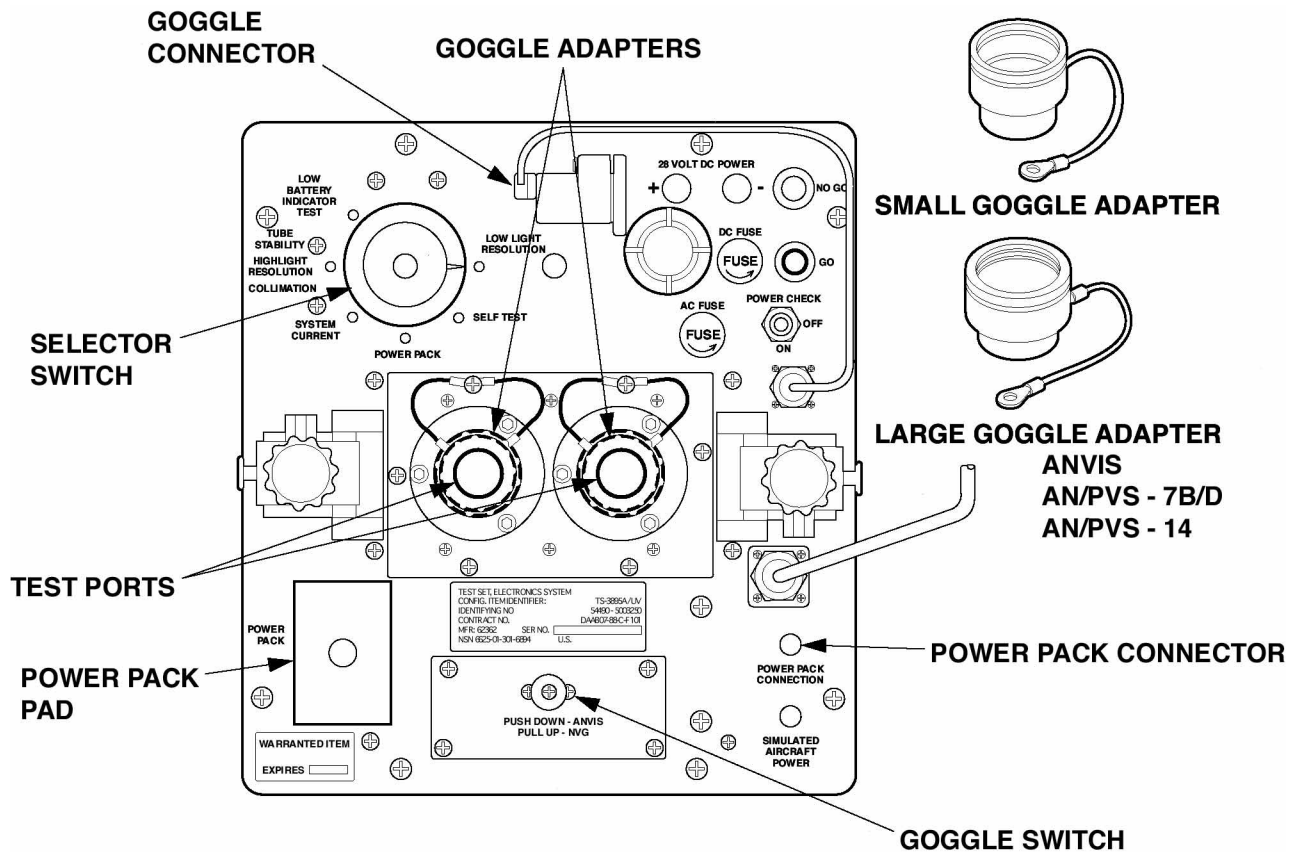

**Figure 3-1. Location of Major Components on Test Set.**



**3-9 TESTING RESOLUTION USING TS-3895A/UV – Continued**

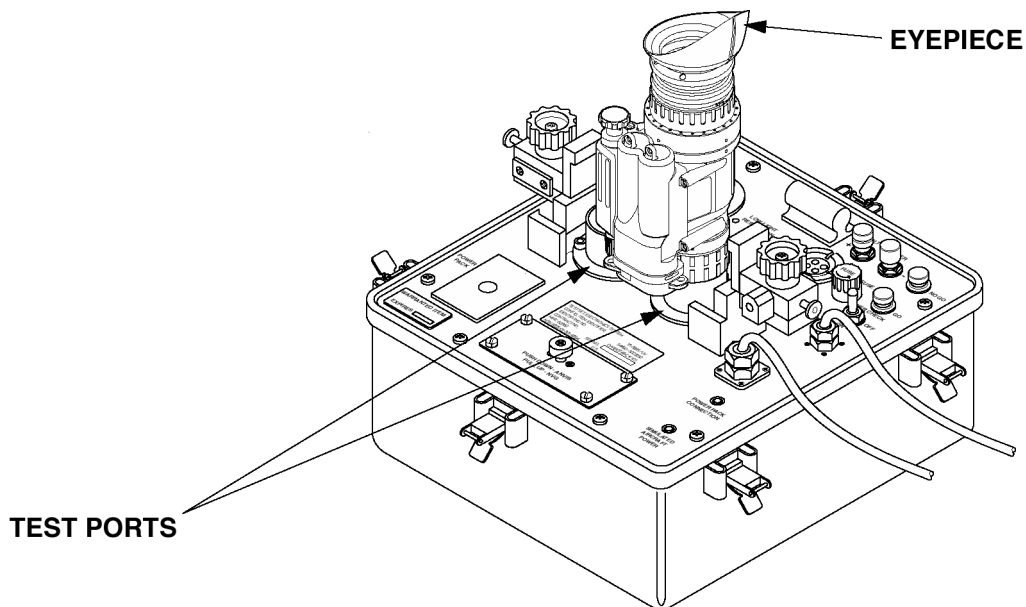

**Figure 3-2. Inserting Monocular into Test Set.**

- (1) Turn the selector switch to the LOW LIGHT RESOLUTION (yellow) position.
- (2) Place the goggle switch in the down position.
- (3) Turn off the room lights and let your eyes adjust to the dark.

**NOTE**

The following test must be performed in a darkened area. Your eyes must be dark-adapted to perform this test. It takes a minimum of 10 minutes to become properly dark-adapted for low light resolution evaluation. However, if you have just been exposed to bright sunlight, dark adaptation will take longer.

**3-9 TESTING RESOLUTION USING TS-3895A/UV - Continued**

- (4) Turn on monocular.
- (5) Turn the gain control fully clockwise, to turn the gain all the way up.
- (6) Focus objective lens and then the eyepiece lens for best focus to obtain the sharpest image.
- (7) Look for flashing, flickering, instability, emission points, or edge glow (refer to TM 11-5855-306-10). If any unacceptable conditions are noted, replace image intensifier (para 3-15).
- (8) Now observe the test pattern. You must be able to distinguish all three horizontal lines and all three vertical lines to count seeing the Element (Figure 3-3). You must be able to see Element 3 on the bottom of the test pattern for monocular to pass.

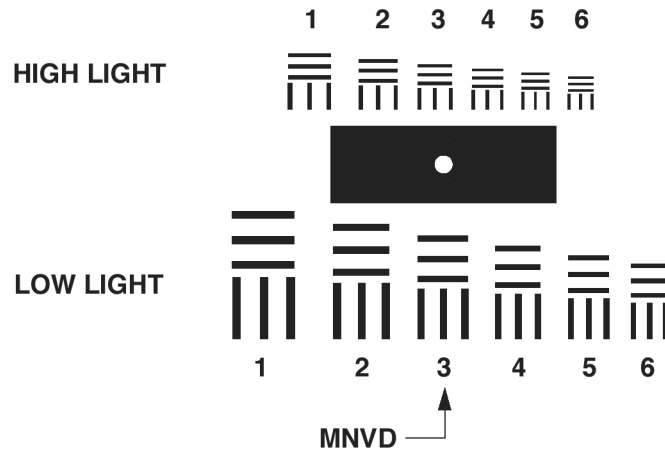

**Figure 3-3. Low Light Element In Resolution Test Pattern.**

- (9) If monocular fails, recheck objective lens and eyepiece lens focus to make sure you have the sharpest image.
- (10) If monocular still fails, refer to Table 3-1 Troubleshooting.

**3-9 TESTING RESOLUTION USING TS-3895A/UV – Continued**

**HIGH LIGHT TUBE RESOLUTION TEST**

- (1) Turn the selector switch to the HIGH LIGHT RESOLUTION (blue) position (Figure 3-1).
- (2) Place the goggle switch in the up position.
- (3) Turn the gain control fully clockwise, to turn the gain all the way up.
- (4) Refocus the objective lens and eyepiece lens to obtain the sharpest image.
- (5) Look for flashing, flickering, shading, or bright spots (refer to TM 11-5855-306-10). If any unacceptable conditions are noted, replace image intensifier (para 3-15).
- (6) Now observe the test pattern. You must be able to distinguish all three horizontal lines and all three vertical lines to count seeing the Element (Figure 3-4). You must be able to see Element 3 on top of the test pattern for monocular to pass.

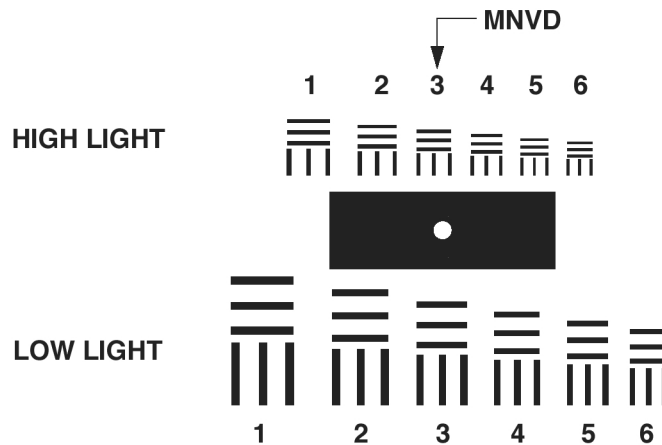

**Figure 3-4. High Light Element In Resolution Test Pattern.**

- (7) If monocular fails, recheck the objective lens and eyepiece lens focus to make sure you have the sharpest image.
- (8) If monocular still fails, refer to Table 3-1 Troubleshooting.

### 3-10 ELECTRICAL TROUBLESHOOTING

If image intensifier does not work after replacing with known good batteries, perform the following procedure to electrically troubleshoot the housing.

---

#### INITIAL SETUP

##### Test Facility

Clean station in the electronic repair service area

##### Tools

None

##### Equipment

Multimeter (Appendix B, Item 3)

##### Materials/Parts

None

---

#### PROCEDURE

- (1) Remove battery housing (para 3-14).

#### NOTE

Check contacts and leads and clean as necessary.

- (2) Set multimeter to measure 3 Vdc.
- (3) With known good batteries in battery compartment, position power switch to ON.
- (4) Apply test probes to the tube contact pins (Figure 3-5). The red test probe goes to positive (+) contact and black test probe goes to negative (-) contact.

#### NOTE

Confirm the monocular or image intensifier is out of warranty period before replacing battery housing or image intensifier (para 1-7).

### 3-10 ELECTRICAL TROUBLESHOOTING – Continued

(5) If 2.5 Vdc to 3.2 Vdc is present, replace image intensifier (para 3-15). If voltage is incorrect, remove and replace battery housing (para 3-14).

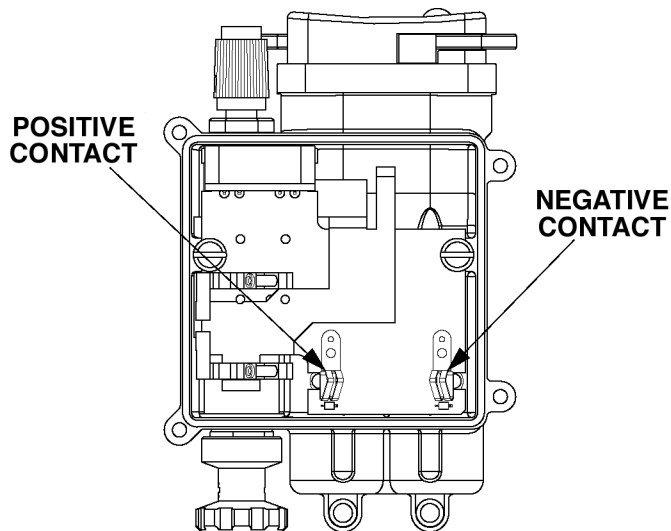

Figure 3-5. Image Intensifier Contact Pin Location.

### 3-11 BLACK SPOT CHECK

Black spots are cosmetic blemishes and do not affect reliability. Generally, you can assume that the black spot was there during acceptance testing. However, occasionally the need may arise to verify the location, size, and number of spots. This test allows the maintainer to evaluate possible out-of-specification black spots, dark spots, or opaque spots in the image area against the specifications for the image intensifier. This test will also allow the isolation of dirt and debris such as hair between the optics.

#### INITIAL SETUP

##### Test Facility

Dark room

##### Tools

Measuring tape

3-volt incandescent flashlight or smaller (Appendix D, Item 11)

Alcohol dispenser (Appendix D, Item 5)

### 3-11 BLACK SPOT CHECK - Continued

#### Equipment

Light source: LED on any other night vision device (AN/PVS-5X, AN/PVS-7X, or MNVD) or an IR light transmitter (Appendix B, Item 14)  
Tripod or fabricated Block Spot Target Test Fixture (Appendix E, Figure E-1, Items 2-8)

#### Materials/Parts

Cotton-tipped applicators (Appendix D, Item 10)  
Isopropyl alcohol (Appendix D, Item 1)  
Data sheet

#### NOTE

- The following test must be performed in a darkened area. Your eyes must be dark-adapted to perform this test. It takes approximately 10 minutes to become properly dark-adapted for low light resolution evaluation. However, if you have been exposed to bright sunlight, dark adaptation will take longer.
- Review the following test procedure before entering the darkened area.
- You will need a flashlight filter to read this procedure while in the darkened area.

### LIGHTS ON

- (1) Set up your dark room as shown in Figure 3-6 or Figure 3-7.

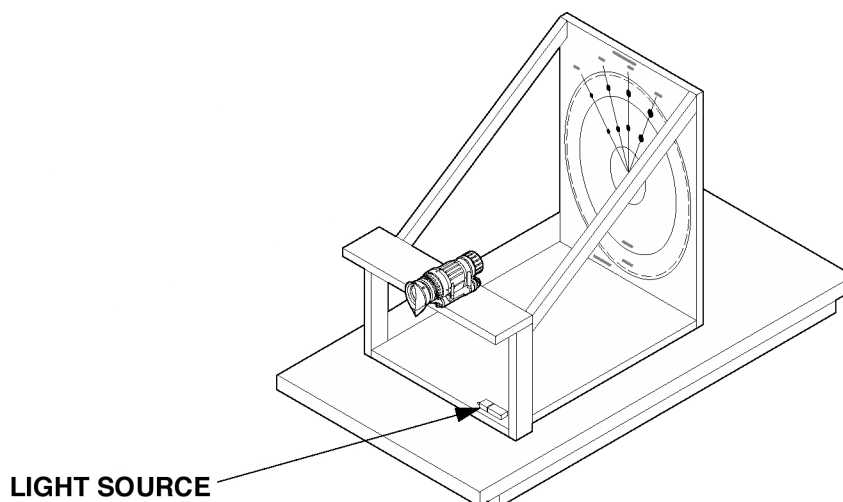

Figure 3-6. Dark Room Setup with Test Fixture.

**3-11 BLACK SPOT CHECK – Continued**

(2) Position the Black Spot Check so the center ring is at eye level during testing.

(3) Clean objective and eyepiece lenses of the systems to be tested by using isopropyl alcohol and cotton-tipped applicators. Moisten applicator with alcohol and use circular motions beginning at the center of the lens and moving in larger circles to the outside of the lens.

(4) Position the monocular to be tested on the tripod or test fixture and secure it. The front surface of the objective lens of monocular should be exactly 30 inches from the target at height of the center ring.

(5) Position the light source behind, to the left, right, top, or bottom of the tripod to prevent shadows on the targets. Make sure that your position when looking through monocular does not produce shadows on the target.

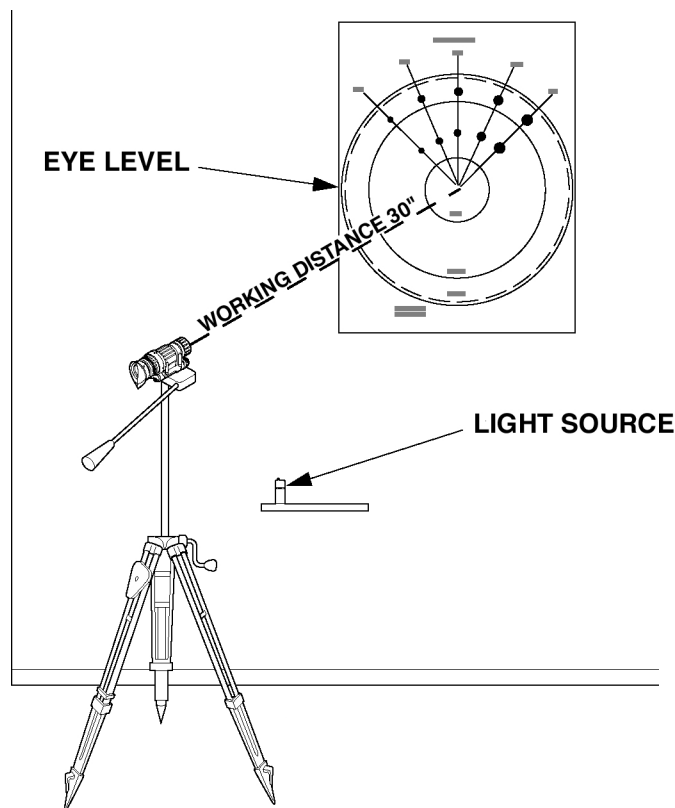

**Figure 3-7. Dark Room Setup with Tripod.**

**3-11 BLACK SPOT CHECK - Continued**

**NOTE**

- The following test must be performed in a darkened area. Your eyes must be dark-adapted to perform this test. It takes a minimum of 10 minutes to become properly dark-adapted for low light resolution evaluation. However, if you have just been exposed to bright sunlight, dark adaptation will take longer.
- Do not reject monocular for resolution unless your eyes have been adequately dark-adapted.
- Review the following test procedure before entering the darkened area.

**LIGHTS OFF**

- (1) Switch off the room lights.
- (2) Turn on monocular and turn the gain control clockwise, to turn the gain all the way up.
- (3) Check the dark room for light leaks using another set of night vision devices (AN/PVS-5X, AN/PVS-7X or AN/PVS-14) and eliminate any leaks you find. Follow good dark room techniques.
- (4) Turn on the light source and look through monocular. Uniformly illuminate the target by moving the light source closer or farther from the target. Eliminate any shadows.
- (5) Alternately adjust objective focus and diopter setting, AT WORKING DISTANCE, until the best focus is achieved. You must have the proper focus and the exact working distance of 30 inches from the front surface of the objective lens to achieve correct results.
- (6) Look at the edge of the spots in the center ring, and move light source forward or back for the best spot contrast. Remember to refocus the objective each time you view a different ring of the chart.
- (7) Use the flashlight to recheck the exact position of monocular at 30 inches ( $\pm 1$  inch). This distance from the target to the objective is critical and must be maintained during testing.



**3-11 BLACK SPOT CHECK – Continued**

**TEST METHOD**

(1) Center the view so it is concentric with the test target rings. (The dotted line represents a circle of 17.5 mm on the cathode surface of image intensifier.) Use the lines to the left and right of the outer circle to accomplish this.

(2) Observe the image for black spots.

**NOTE**

The total diameter of image intensifier may vary between 17.5 mm and 18.5 mm. Evaluate only those black spots in the area of the image inside the 17.5 mm circle. The dotted line in the second ring marks this 17.5 mm area. Spots that are located outside the dotted circle are not a cause for rejecting image intensifier.

(3) Identify the ring of the chart that bounds the black spot you are evaluating.

(4) Refocus the objective for the best focus on the ring of the chart identified above.

(5) Using the allowable spot-size chart in that particular ring, determine the size of the black spot.

**NOTE**

Circular spots will correspond easily to this chart. However, irregular (non-circular) spots require you to judge the area of the spot in question against the area of the circular spot on the chart.

(6) Count the number of spots, by spot size, in each ring and record these figures.

**PASS/FAIL CRITERIA**

(1) Refer to Table 3-2 listing allowable spots and sizes to determine if the image intensifier under test should be rejected.

**Table 3-2. Monocular Allowable Black Spots and Sizes.**

Size of spots (inches)	Number of Spots within 0.22 inch diameter circle	Number of spots within annulus bounded by 2 circles 0.22 and 0.58 inch diameter	Number of spots within annulus bounded by circles 0.58 inch diameter and total screen diameter
0.009 or larger	0	0	0
0.006 to 0.009	0	1	2
0.003 to 0.006	0	2	3

**NOTE:** The 0.22 and 0.58 inch circles on the image screen shall be concentric with the optical axis of the assembly.

**3-11 BLACK SPOT CHECK - Continued**

(2) The image intensifier fails if the black spot (circular) is larger than the maximum spot size indicated on the chart for the ring in which the spot (circular) is located, or if the number of spots exceeds the number of spots allowed for that ring.

(3) The image intensifier fails if the maintenance person determines, by comparison, that the area of the non-circular spot is larger than the area of the largest circular spot designated in that ring. This will be a subjective evaluation so remember that these spots were evaluated before Government acceptance at the contractor's plant and passed. Judging the area is difficult. See Examples 1 and 2 of Figure 3-8. Do not reject an image intensifier for an irregularly shaped spot by its diameter alone.

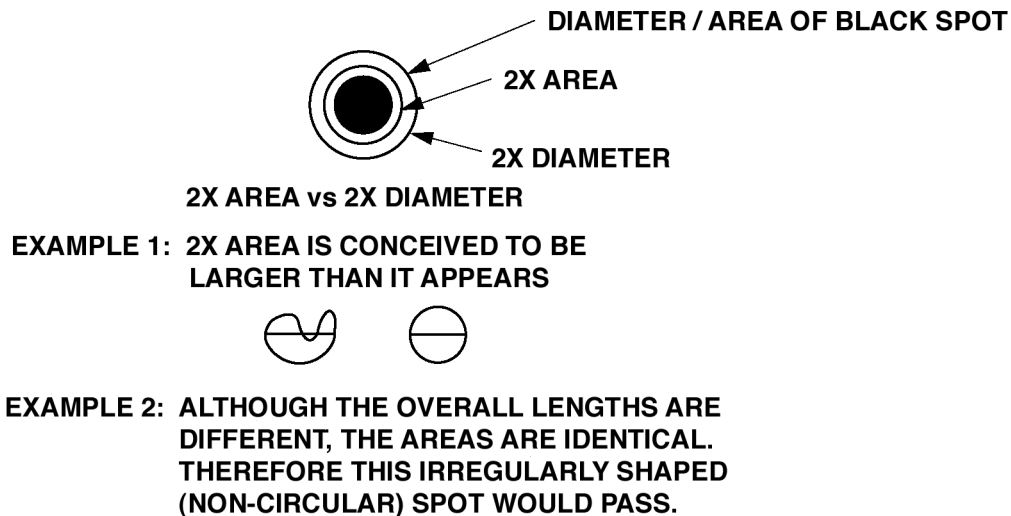

**Figure 3-8. Black Spot Evaluation.**

(4) Consider two spots and the distance between them as one spot anytime that this distance between the two spots is less than the diameter of either spot. The image intensifier fails if this total dimension (diameter) is greater than the allowable spot size diameter for the ring in which the spots are located.

(5) A shaded area may surround a black spot. Consider the shaded area as part of the spot if the high light level resolution chart cannot be read through the shaded area (DS is to determine using TS-3895A/UV). The image intensifier fails if the combined area of the spot and the shaded area exceed the maximum area of the largest spot for the ring in which the spot is located.

(6) Do not reject an image intensifier for a black spot that is located outside the dotted ring on the black spot chart.

### 3-11 BLACK SPOT CHECK – Continued

#### NOTE

If an image intensifier is rejected on the basis of this test for black spots, do not immediately reject the system for a defective image intensifier. It is possible that some of the spots may be caused by contamination inside the monocular and on the surfaces of the optics. You must disassemble the monocular and clean and inspect for dirt, debris, fingerprints, or other foreign material. Reassemble monocular and recheck the image area for black spots.

### Section V. Direct Support Maintenance Procedures

The following procedures detail removal and installation of assemblies as authorized by the MAC located in Appendix B in this manual.

### 3-12 REMOVAL, REPAIR, AND REPLACEMENT OF EYEPIECE LENS

If an eyepiece lens is defective, it can be removed, repaired, and replaced without disassembling the monocular.

---

#### INITIAL SETUP

##### Test Facility

Clean station in the electronic repair service area

##### Tools

Spanner wrench (Appendix B, Item 10)  
Screwdriver, flat-tipped (Appendix B, Item 9)  
10X (or greater) eye loop or magnifier (Appendix B, Item 19)  
Retaining ring pliers (Appendix B, Item 16)  
Alcohol dispenser (Appendix D, Item 5)  
Heat Gun (Appendix B, Item 17)  
Needle Nose Pliers (Appendix B, Item 18)

##### Materials/Parts

Eyepiece lens, 25 mm (Appendix C, Figure C-2, Item 7)  
O-ring (Appendix C, Figure C-2, Item 5)  
Cotton-tipped applicators (Appendix D, Item 10)  
Isopropyl alcohol (for glass lenses) (Appendix D, Item 1)

**3-12 REMOVAL, REPAIR, AND REPLACEMENT OF EYEPIECE LENS – Continued**

Can of compressed air (Appendix D, Item 9)  
Lubricant (Silicone Grease), (Appendix D, Item 2)  
Eyepiece Retaining Ring (Appendix C, Figure C-3, Item 7)  
Epoxy Adhesive (Appendix D, Item 12)  
Shop towels (Appendix D, Item 6)  
Lens paper (Appendix D, Item 7)

**NOTE**

Confirm the monocular is out of warranty period before replacing the eyepiece lens (para 1-7).

**REMOVAL**

The eyepiece lens attaches to the large-diameter end of the monocular housing and is secured with a locking ring. Remove lens as described below.

**NOTE**

It may facilitate removing the eyepiece lens by allowing an airflow behind the lens. To allow this, remove purge screw using a screwdriver.

Normal Procedure

- (1) Hold the monocular so eyepiece faces you.
- (2) Set eyepiece focus ring to +2, then use the spanner wrench to turn eyepiece locking ring clockwise (Figure 3-9).

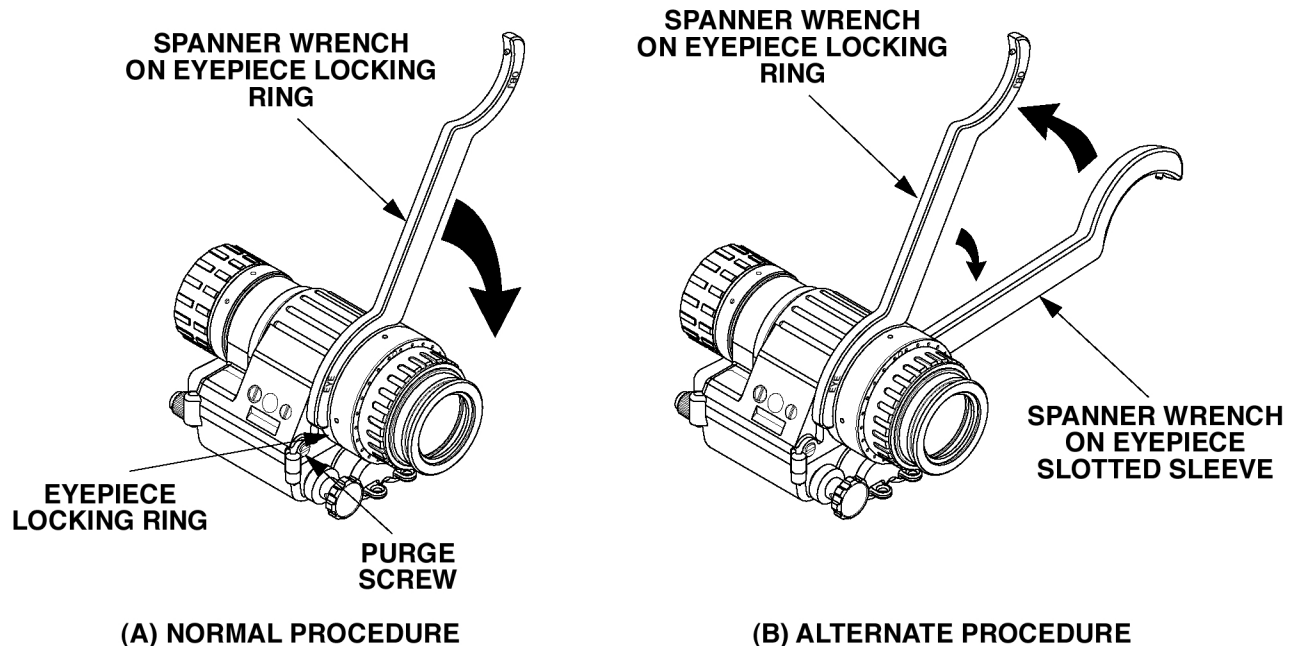

**3-12 REMOVAL, REPAIR, AND REPLACEMENT OF EYEPIECE LENS – Continued**

(3) Grasp the eyepiece lens (less eyepiece locking ring) and turn it counterclockwise until it separates from monocular housing.

**NOTE**

You may remove eyepiece locking ring, to replace if needed.

Alternate Procedure

**NOTE**

Use this procedure if the locking ring does not turn free of eyepiece.

(1) Hold the monocular so eyepiece faces you.

(2) Set eyepiece focus ring to +2, then use the spanner wrench to turn the eyepiece locking ring clockwise (Figure 3-9).

(3) Apply the eyepiece spanner wrench to the eyepiece locking ring. Apply the second eyepiece spanner wrench to the large flange of the eyepiece. Locate the two spanner wrenches so that they form a "V" with the handles spread approximately 15° to 30° apart in order to break the bond of the locking ring/eyepiece.

(4) Support the monocular housing that is being disassembled with one hand. Use the other hand to squeeze the two spanner wrenches together at the wide portion of the "V" form and free the bond of the locking ring and eyepiece. Continue to support monocular housing with one spanner wrench engaged with locking ring with one hand.

(5) Grasp the eyepiece (less eyepiece locking ring) and turn it counterclockwise until it separates from monocular housing.

**NOTE**

You may remove eyepiece locking ring, to replace if needed.

**NOTE**

Clean bonding material from parts prior to reassembling locking ring and eyepiece.

**3-12 REMOVAL, REPAIR, AND REPLACEMENT OF EYEPIECE LENS – Continued**

**REPAIR**

Repair eyepiece lens (Figure 3-10) according to the following steps.

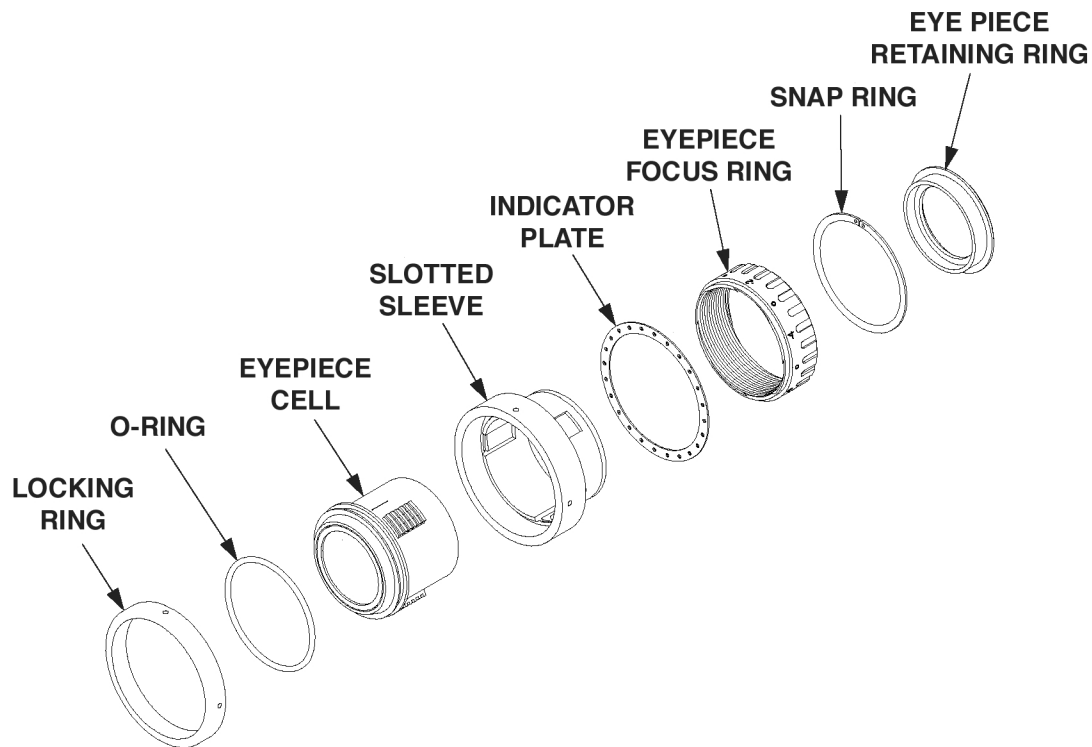

**Figure 3-10. Components of Eyepiece Lens.**

- (1) To remove eyepiece retaining ring, use a heat gun to heat entire eyepiece retaining ring for approximately three minutes
- (2) Place needle nose pliers between the lip of the eyepiece retaining ring and the eyepiece, lift to remove
- (3) With one hand, hold eyepiece by its largest diameter so the outside of lens faces you and support the end of the eyepiece cell with the palm of your hand. Use your other hand to turn eyepiece focus ring clockwise until continued turning does not cause the eyepiece cell to move anymore. At this point, the threads are no longer engaged. Do not let eyepiece cell drop.
- (4) Pull eyepiece cell out of the eyepiece focus. Using the 10X eye loop or magnifier, inspect O-ring for nicks, cuts, or flat spots. If it is defective, replace it as described in step 5. If not, proceed to step 6.

**3-12 REMOVAL, REPAIR, AND REPLACEMENT OF EYEPiece LENS – Continued**

**CAUTION**

Do not use a sharp implement to remove O-ring.

(5) To remove O-ring from the eyepiece cell, use the fingers of one hand to squeeze O-ring and at the same time slide your fingers up to push part of O-ring out of its groove. Grasp O-ring with the fingers of your other hand and pull it off the eyepiece cell.

(6) Inspect the eyepiece cell and eyepiece focus and replace any piece that is broken, excessively worn, or has damaged threads. Use a magnifier to confirm any suspected damage.

**CAUTION**

- Do not use petroleum jelly to lubricate o-ring.
- Do not get any fingerprints or lubrication on lens surfaces of the cell. The lens has a magnesium fluoride coating on its surface and is easily damaged. Clean lens immediately with cotton-tipped applicators and isopropyl alcohol.

(7) Using a cotton-tipped applicator, apply a light coat of lubricant around new O-ring and carefully slip it into the groove on eyepiece cell. Also, lightly coat the three exposed threaded sections of eyepiece cell.

**CAUTION**

Do not lubricate the threads on the inside of eyepiece focus ring or the threads on the outside of monocular housing.

(8) Set eyepiece focus ring so the white reference dot lines up with the -2 mark.

(9) Holding the eyepiece cell so you do not touch lenses, align the threaded segments of the lens cell with the slots in the eyepiece focus ring and carefully push the cell into the eyepiece focus ring until it stops.

(10) Cover the interior lens surface of eyepiece cell with clean lens paper and grasp the large flange of eyepiece focus ring between the thumb and middle finger of one hand while pressing on the rim of the lens cell with your index finger (Figure 3-11). Hold eyepiece focus ring with the fingers of the other hand and at the same time, gently press on the rim of the lens cell and turn eyepiece focus ring counterclockwise to engage the threads. Continue to turn focus knob counterclockwise until it stops. Do not overtighten. The +2 mark must stop to the left of the dot (looking at the numbers so they are upright) but not beyond the second hole to the left of white reference dot (Figure 3-12). If dot does not align within these limits, proceed to the next step. If white dot does align within the limits, go to INSTALLATION.

**3-12 REMOVAL, REPAIR, AND REPLACEMENT OF EYEPIECE LENS – Continued**

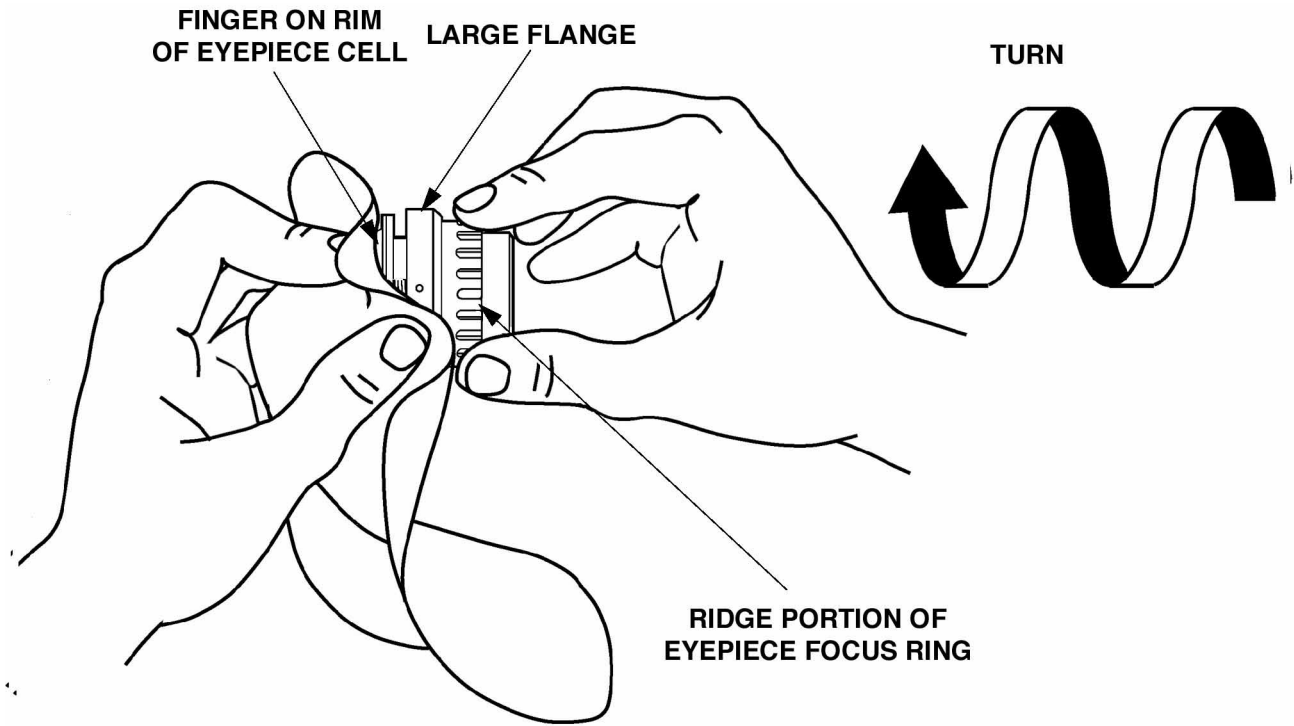

**Figure 3-11. Inserting Eyepiece Lens Cell into the Eyepiece Focus Ring.**

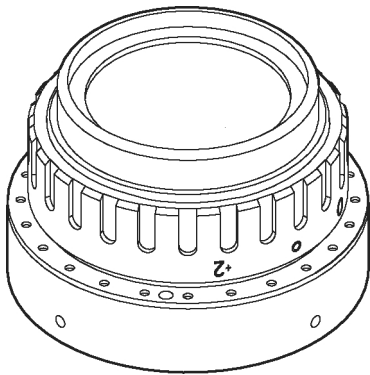

**Figure 3-12. Identifying the Limits for Diopter Plus (+) Travel.**

(11) Rotate eyepiece focus ring clockwise past the -2 mark once and stop at the -2 mark on the second turn.



**3-12 REMOVAL, REPAIR, AND REPLACEMENT OF EYEPIECE LENS – Continued**

(12) Withdraw the eyepiece lens cell and turn it one-third turn in either direction. Reinstall the lens cell as described in step 8. If the dot aligns within the limits of step 8, go to INSTALLATION. If white reference dot still does not align within the limits, repeat steps 9 and 10 a second time, but make sure to turn the lens cell the same direction as the first time. If dot still does not align, move indicator plate as described below in steps 11 through 16.

(13) Position the lens cell so the +2 mark and white reference dot are the closest to the requirements described in step 8.

(14) Turn focus ring fully counterclockwise. Note how far and in what direction you need to move the indicator plate to meet the requirement.

(15) Using the retaining pliers, carefully remove the snap ring on the end of eyepiece.

(16) With eyepiece sitting on a flat surface, small diameter up, rotate eyepiece focus ring slightly clockwise until there is just enough room to move the indicator plate to another hole.

(17) Move indicator plate the amount and in the direction determined in step 12. The white reference dot should line up with the +2 mark. If it does not, the following is still acceptable: The white dot is in the nearest position to the right of the +2 mark (as you would look into the eyepiece).

(18) Using the retaining pliers, replace snap ring. Make sure it is seated in its groove and does not bind the lens cell.

**INSTALLATION**

**CAUTION**

Take care not to apply too much epoxy adhesive to the eyepiece retaining ring.

**CAUTION**

Prior to installation of eyepiece retaining ring, Zero Diopter must be set

The reassembled eyepiece cell, O-ring, and eyepiece focus ring are reattached to monocular housing as follows:

(1) Use alcohol to clean any remaining epoxy adhesive from eyepiece.

(2) Apply a thin bead of epoxy adhesive to eyepiece retaining ring and insert eyepiece retaining ring into eyepiece. (Figure 3-13)

(3) Turn eyepiece retaining ring one-quarter turn to evenly smooth epoxy adhesive between eyepiece retaining ring and eyepiece.

(4) Place eyepiece on a flat surface with the eyepiece retaining ring down to prevent epoxy adhesive from flowing onto the eyepiece lens.

**3-12 REMOVAL, REPAIR, AND REPLACEMENT OF EYEPIECE LENS – Continued**

- (5) Allow seven days for epoxy adhesive to cure.
- (6) If monocular's purge screw has not been removed, use a screwdriver to remove it.

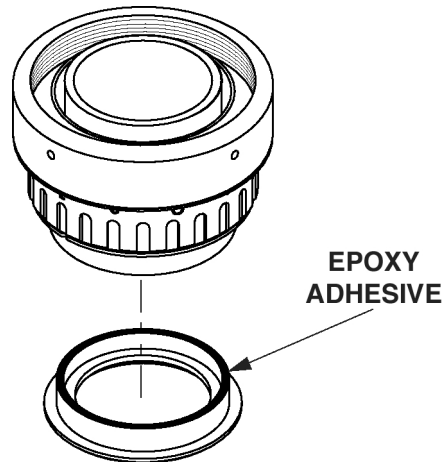

**Figure 3-13. Applying Epoxy Adhesive to Eyepiece Retaining Ring**

(7) Make sure the surfaces of both interior eyepiece lens and image intensifier's output optics are clean. If not, clean them with a cotton-tipped applicator moistened with isopropyl alcohol. Rub gently in a circular motion starting at the center and move outward with larger circles. Using clean compressed or canned air or nitrogen, blow out monocular housing to remove any lint or foreign material.

**CAUTION**

Do not get any lubricant on the threads on the outside of monocular housing.

(8) Apply a light coat of lubricant to the inside surface of Monocular housing where the O-ring will travel (Figure 3-14).

**3-12 REMOVAL, REPAIR, AND REPLACEMENT OF EYEPIECE LENS – Continued**

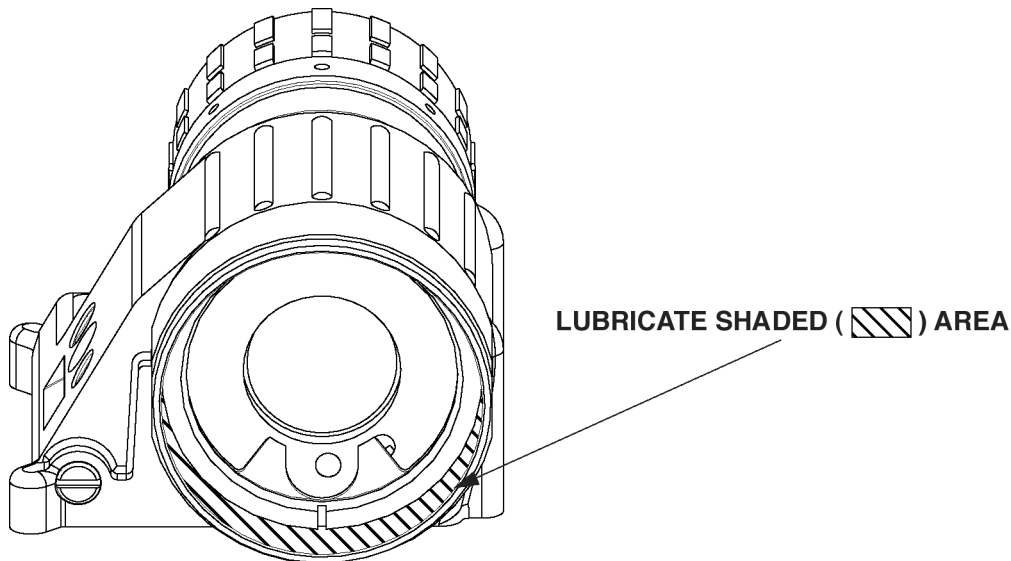

**Figure 3-14. Applying Lubricant to Inside of Monocular Housing.**

**NOTE**

Make sure the range of travel of eyepiece focus ring is at least +2 to -6. The +2 mark should not move past the second hole to the left of the white dot. If it moves too far, move indicator plate as described under REPAIR steps 11 through 16.

(9) Rotate eyepiece focus ring (Figure 3-15) counterclockwise so the white dot lines up with the +2 mark. Carefully insert eyepiece onto the monocular. Turn the large flange counterclockwise until you hear it click and then turn it clockwise two or three full turns.

(10) Set zero diopter for eyepiece (para 3-13).

(11) Purge the system (para 3-19).

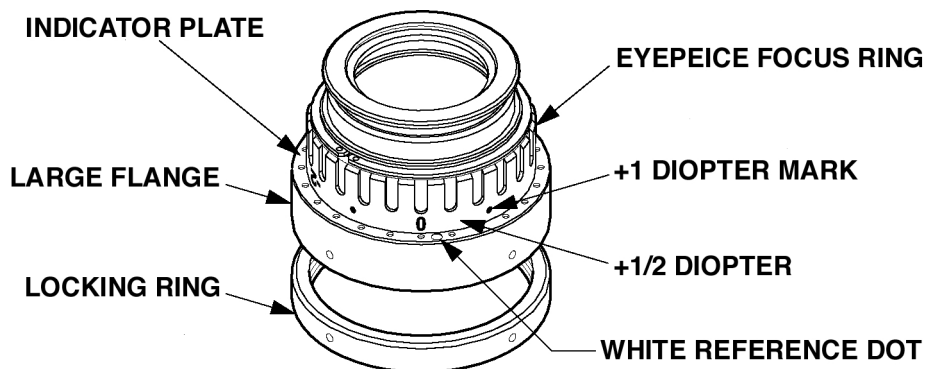

**Figure 3-15. Setting Zero Diopter.**

### 3-13 SETTING ZERO DIOPTER FOR EYEPIECE

---

#### INITIAL SETUP

##### Test Facility

Electronic repair service area. You do not need a dark room to check the diopter setting; however, it needs to be dim enough to see the targets.

##### Tools

Locking ring wrench (Appendix B, Item 10)  
Alcohol dispenser (Appendix D, Item 5)

##### Equipment

Test set, TS-3895A/UV with large goggle adapter and diopter scope (**Army**) (Appendix B, Item 2)  
Test set, TS-4348/UV (**Marine Corps**) (Appendix B, Item 1)  
Diopter scope (**Marine Corps**) (Appendix B, Item 4)

##### Materials/Parts

Cotton-tipped applicators (Appendix D, Item 10)  
Isopropyl alcohol (Appendix D, Item 1)

Use TM 11-5855-264-14, Operator's, Aviation Unit, Direct Support, and General Support Maintenance Manual for TS-3895A/UV test set, to set up the test set and perform self-test.

---

### SETTING ZERO DIOPTER USING TS-3895A/UV PROCEDURES (ARMY ONLY)

- (1) Remove eyecup/eyeguard per TM 11-5855-306-10, Operator's Manual, Monocular Night Vision Device (MNVD), AN/PVS-14.
- (2) Clean objective and eyepiece lens of the monocular by using isopropyl alcohol and cotton-tipped applicators. Moisten applicator with alcohol and use circular motions beginning at the center of the lenses and moving in larger circles to the outside of the lenses.
- (3) While holding the monocular, loosen its eyepiece locking ring (Figure 3-9) using the end of the spanner wrench marked EYE and turn it clockwise.
- (4) Turn the gain control fully clockwise, to turn the gain all the way up.
- (5) Attach the large goggle adapter to either test port on the test set and cover remaining test port.

**3-13 SETTING ZERO DIOPTER FOR EYEPIECE – Continued**

- (6) Insert monocular into the large goggle adapter, objective lens down.
- (7) Turn the selector switch to COLLIMATION (blue) position.
- (8) Remove the diopter scope stored in the collimation attachment by loosening the locking knob counterclockwise.
- (9) Place the collimation attachment over monocular with shutter knob facing you. Push the clamps into the notches on the sides of the attachment. Tighten locking knobs clockwise (Figure 3-16).

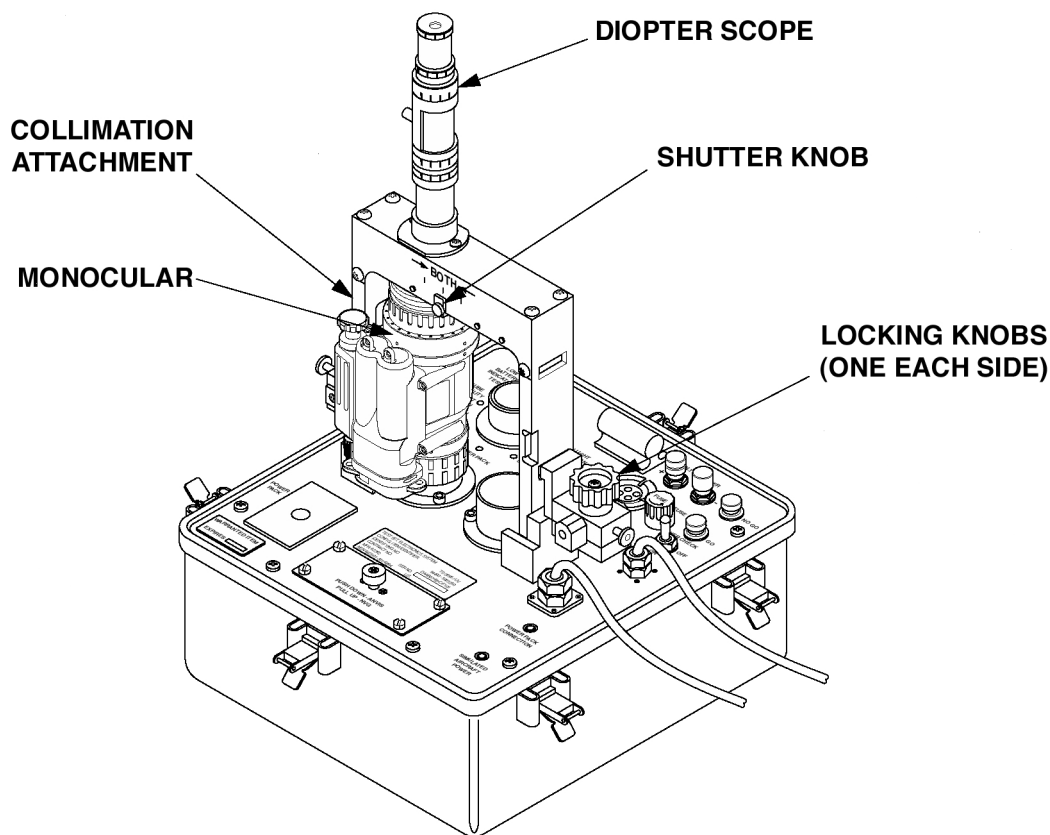

**Figure 3-16. Attaching Collimator and Diopter Scope.**

- (10) After cleaning lenses, insert the large end of the diopter scope into the collimation attachment.
- (11) Close the shutter over the test port not being used by positioning the shutter knob over that test port. Be sure the goggle switch is in the UP position for this test.
- (12) Dim the room lights and let your eyes adjust.
- (13) Turn the objective lens fully counterclockwise.

**3-13 SETTING ZERO DIOPTR FOR EYEPIECE – Continued**

(14) While holding the large flange of the eyepiece, turn the eyepiece focus ring to approximately -2 and then counterclockwise so the 0 mark aligns with the white reference dot (Figure 3-15) on the indicator plate. Try not to go past the 0 mark. If you do, turn the focus ring back to -2 and then try again. This is necessary to account for backlash in the focus ring.

**NOTE**

Always check and/or set the zero diopter by turning the eyepiece focus ring in a counterclockwise direction beginning from the minus (-) diopter direction to account for backlash in the focus ring.

(15) Look through diopter scope and turn the large flange of the eyepiece lens (Figure 3-16) clockwise until the pattern is seen.

(16) Adjust the objective lens for best focus on the screen. The projected image will not be sharp (Figure 3-17).

**NOTE**

- The user must correctly recognize the point of focus on the screen of the image intensifier. While the projected image will not be sharp (because of the diopter scope's very high magnification), the screen of the intensifier will be sharp when correct focus is achieved.
- The image will appear as a very fine mesh pattern, looking somewhat like a section of fabric or screen wire under magnification. Figure 3-17 shows the mesh as viewed with the TS-3895A/UV.

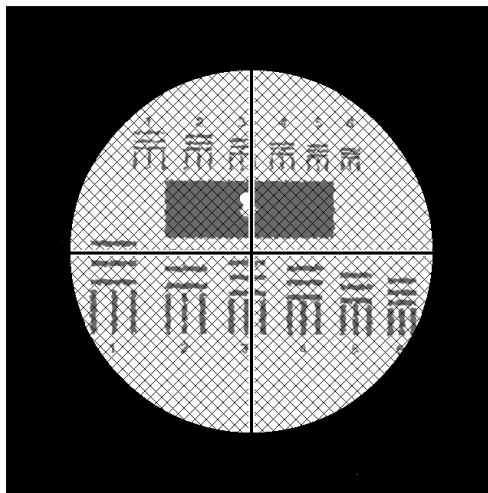

**Figure 3-17. Properly Focused Diopter Image Using TS-3895A/UV.**

**3-13 SETTING ZERO DIOPTR FOR EYEPIECE – Continued**

(17) Adjust the large flange of eyepiece lens for the best focus or until it bottoms out if best focus is not achieved. Keep the white referenced dot and 0 mark in line.

**NOTE**

The white reference dot on the indicator plate may be at any point around the eyepiece.

**CAUTION**

Do not use any adhesive to set locking rings.

(18) Use a spanner wrench to tighten the eyepiece-locking ring. Take care not to let the lens rotate.

(19) Turn eyepiece focus ring fully clockwise until it stops. Look through diopter scope and adjust eyepiece focus ring for best focus, always approaching best focus in a counterclockwise direction.

(20) The eyepiece diopter setting should be set at 0 diopter. If the setting exceeds 0 ( $\pm 1/2$  diopter, Figure 3-15), go back to step 17 to reset zero diopter.

(21) Turn the ON/OFF/POWER CHECK switch to OFF.

(22) Turn the room lights back on.

(23) Remove collimation attachment and diopter scope from test set.

**CAUTION**

To prevent damage to the image intensifier, always turn the monocular's power switch to OFF before removing the monocular from test set.

(24) Purge the system.(para 3-19).

**ALTERNATE ZERO DIOPTR SETTING USING TS-4348/UV PROCEDURES  
(MARINE CORPS)**

**LIGHTS ON**

(1) Remove eyecup/eyeguard per TM 11-5885-306-10, Operator's Manual, Monocular Night Vision Device (MNVD), AN/PVS-14.

(2) If found dirty, clean objective and eyepiece lenses of the monocular by using isopropyl alcohol and cotton-tipped applicators. Moisten applicator with alcohol and use circular motions beginning at the center of the lenses and moving in larger circles to the outside of the lenses.

### 3-13 SETTING ZERO DIOPTR FOR EYEPIECE – Continued

- (3) While holding the monocular, loosen its eyepiece-locking ring (Figure 3-9) using the end of the spanner wrench marked EYE and turn it clockwise.
- (4) Turn the gain control fully clockwise, to turn the gain all the way up.
- (5) Insert monocular into the TS-4348/UV test port, objective lens down.
- (6) Place the HIGH/LOW switch to HIGH position.
- (7) Adjust diopter scope eyepiece while looking at a blank wall so that the crossed reticle lines are in best focus for your eye.
- (8) Adjust diopter scope for a setting of 0 diopter.
- (9) Dim the room lights and let your eyes adjust.
- (10) Turn objective lens fully counterclockwise.

#### NOTE

Always check and/or set the zero diopter by turning eyepiece focus ring in a counterclockwise direction beginning from the minus (-) diopter direction to account for backlash in the focus ring.

- (11) While holding the large flange of the eyepiece, turn the eyepiece focus ring to approximately -2 and then counterclockwise so the 0 mark aligns with the white reference dot on the indicator plate. Try not to go past the 0 mark. If you do, turn the focus ring back to -2 and then try again. This is necessary to account for backlash in the focus ring. (Figure 3-15).
- (12) Hold diopter scope in place over the monocular eyepiece.
- (13) Turn ON test set by setting the "II/OFF/III" switch to the "III" position.
- (14) Turn ON monocular.
- (15) Look through diopter scope and turn the large flange of the eyepiece lens (Figure 3-16) clockwise until the pattern is seen.
- (16) Adjust objective lens for best focus. The projected image will not be sharp.



### 3-13 SETTING ZERO DIOPTR FOR EYEPIECE – Continued

#### NOTE

- The user must correctly recognize the point of focus on the screen of the image intensifier. While the projected image will not be sharp (because of the diopter scope's very high magnification), the screen of the intensifier will be sharp when correct focus is achieved.
- The image will appear as a very fine mesh pattern, looking somewhat like a section of fabric or screen wire under magnification. (Figure 3-17).

(17) Adjust the large flange of the eyepiece lens for the best focus or until it bottoms out if best focus is not achieved. Keep the white referenced dot and 0 mark in line (Figure 3-15).

#### NOTE

The white reference dot on the indicator plate may be at any point around the eyepiece.

#### CAUTION

Do not use any adhesive to set locking rings.

(18) Use a spanner wrench to tighten eyepiece lock ring by turning counterclockwise. Take care not to let the lens rotate.

(19) Turn eyepiece focus ring fully clockwise until it stops. Look through diopter scope and adjust eyepiece focus ring for best focus, always approaching best focus in a counterclockwise direction.

(20) The eyepiece diopter setting should be set at 0 diopter. If setting exceeds 0 ( $\pm 1/2$  diopter, (Figure 3-15), go back to step 17 to reset the zero diopter.

### 3-14 REMOVAL AND INSTALLATION OF BATTERY HOUSING

#### INITIAL SETUP

##### Test Facility

Clean station in the electronic repair service area

### 3-14 REMOVAL AND INSTALLATION OF BATTERY HOUSING – Continued

#### Tools

Hex wrench 5/64" (Appendix B, Item 9)  
Magnifier (Appendix B, Item 19)  
Thin-tipped needle nose pliers (Appendix B, Item 18)  
4" or 5" general purpose tweezers (Appendix B, Item 9)

#### Materials/Parts

Lubricant (Silicone Grease), (Appendix D, Item 2)  
O-ring (Appendix C, Figure C-2, Item 10)

---

#### **NOTE**

Confirm the monocular is out of warranty period before replacing battery housing (para 1-7).

#### **REMOVAL**

#### **CAUTION**

Be careful not to damage the flex circuit connecting the two assemblies.

(1) Using a 5/64" hex wrench, remove the four screws that secure battery housing to monocular housing and gently rotate the battery housing away from the monocular housing in the orientation shown in Figure 3-18.

**3-14 REMOVAL AND INSTALLATION OF BATTERY HOUSING – Continued**

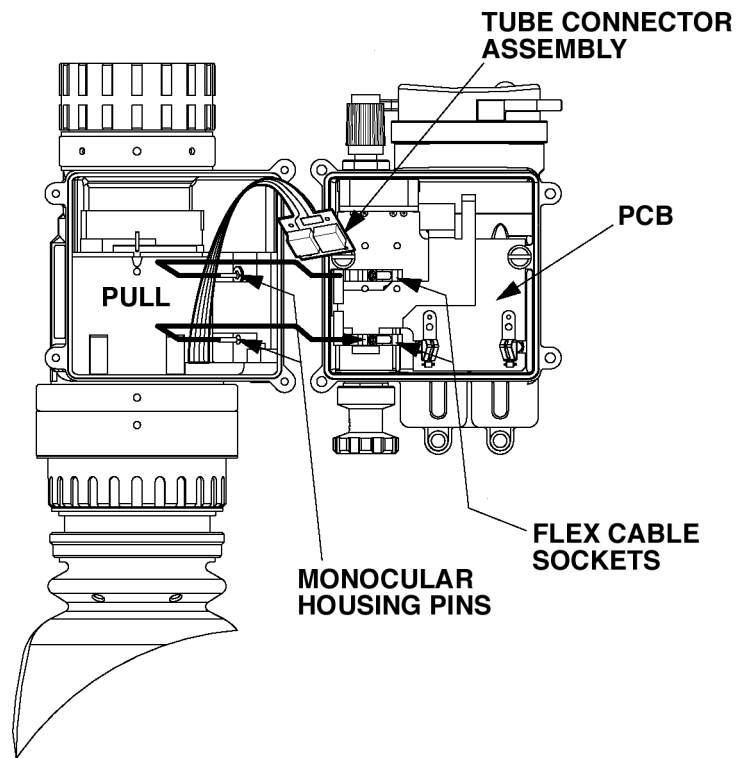

**Figure 3-18. Battery Housing Connections.**

**CAUTION**

Do not remove the tube connector by pulling the flex cable.

- (2) Using fingers, gently lift the tube connector away from the Printed Circuit Board (PCB).
- (3) Using thin-tipped needle nose pliers or tweezers, firmly grasp the two sockets on the flex cable and pull off the two pins in the monocular housing.

**INSTALLATION**

- (1) Inspect O-ring and replace if damaged.
- (2) Apply a light coating of lubricant on O-ring before inserting it into the groove in the battery housing (Figure 3-19).

**3-14 REMOVAL AND INSTALLATION OF BATTERY HOUSING – Continued**

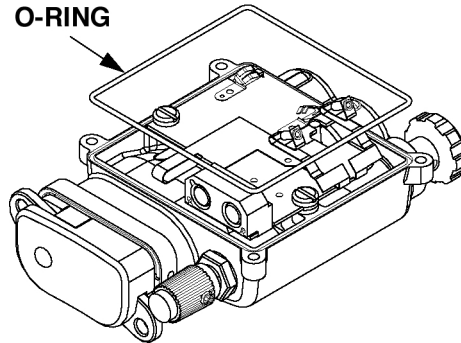

**Figure 3-19. Installing O-Ring.**

(3) Place the battery housing and monocular on the workbench in the orientation shown in Figure 3-20.

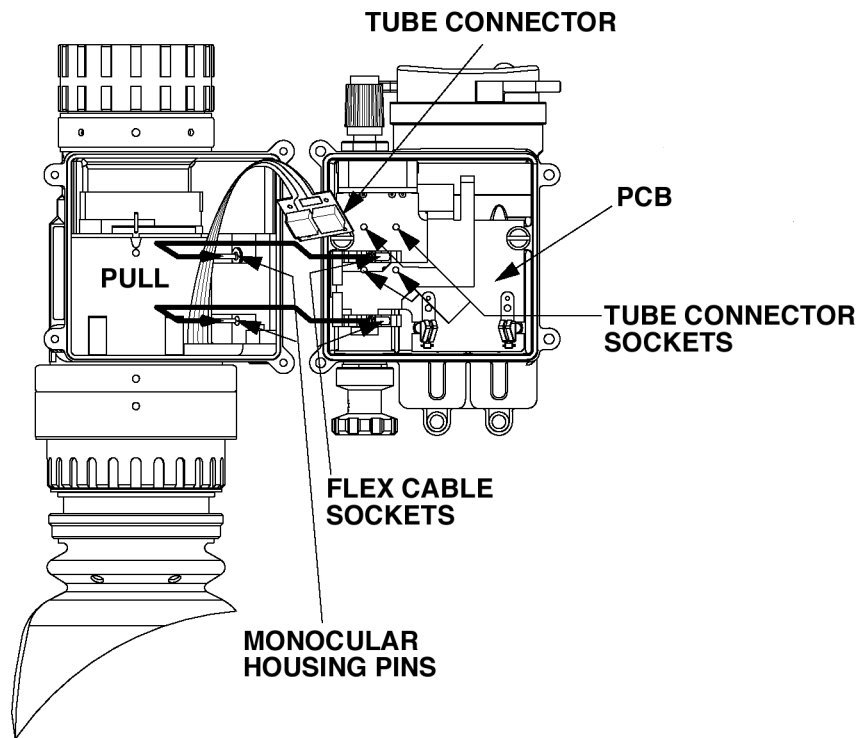

**Figure 3-20. Wire Connections.**

(4) Push the two sockets onto the two pins on the monocular housing, making sure the sockets are fully seated on the pins (Figure 3-20).

**3-14 REMOVAL AND INSTALLATION OF BATTERY HOUSING – Continued**

**CAUTION**

Take care not to bend or break pins. Ensure that pins are aligned in the correct position.

(5) Insert the four pins on the flex board into the four sockets on the PCB.

(6) Making sure that the two flex circuit leads fold toward the inside of the housing, gently rotate battery housing into place and align the holes for the four mounting screws.

**CAUTION**

- Take care to ensure that the circuit wiring is not pinched between battery housing and monocular housing.
- Do not over tighten the four mounting screws.

(7) Replace the four screws using the 5/64" hex wrench. Tighten screws on alternate corners snug, i.e. first 1, then 2, then 3, then 4 as shown in Figure 3-21.

(8) Purge the system (para 3-19).

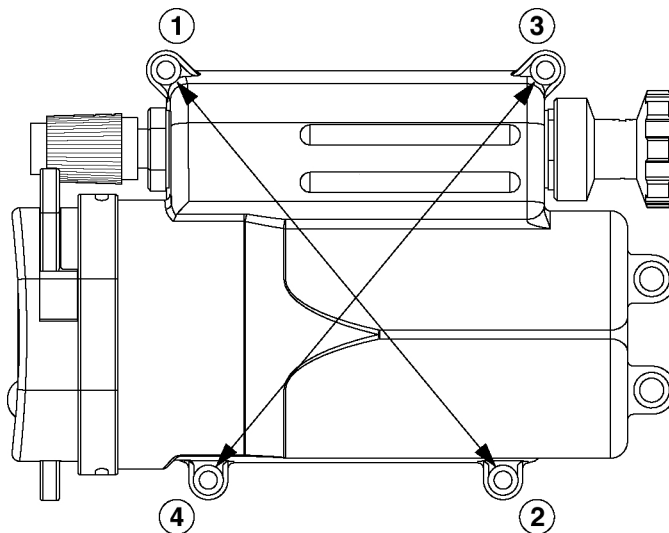

**Figure 3-21. Tightening Screws.**

## 3-15 REMOVAL AND INSTALLATION OF IMAGE INTENSIFIER

---

### INITIAL SETUP

#### Test Facility

Clean station in the electronic repair service area

#### Tools

Tube retainer wrench (Appendix B, Item 12)

**(Marine Corps)** Alternate spanner wrench (1-33/64) (Appendix B, Item 11)

Alcohol dispenser (Appendix D, Item 5)

#### Materials/Parts

Compressed air or nitrogen (Appendix D, Item 9)

Cotton-tipped applicators (Appendix D, Item 10)

Image intensifier (Appendix C, Figure C-2, Item 2)

Isopropyl alcohol (Appendix D, Item 1)

Lens paper (Appendix D, Item 7)

---

### **WARNING**

#### **Toxic Material**

The image intensifier's phosphor screen contains toxic materials.

- If an image intensifier breaks, be extremely careful to avoid inhaling the phosphor screen material. Do not allow the material to come in contact with the mouth or open wounds on the skin.
- If the phosphor screen material contacts your skin, wash it off immediately with soap and water.
- If you inhale/swallow any phosphor screen material, drink a lot of water, induce vomiting, and seek medical attention as soon as possible.

### **NOTE**

Confirm the image intensifier is out of warranty period before replacing image intensifier (para 1-7).

**3-15 REMOVAL AND INSTALLATION OF IMAGE INTENSIFIER – Continued**

**REMOVAL**

- (1) Remove eyepiece lens (para 3-12).
- (2) Remove battery housing (para 3-14).
- (3) Using tube retainer wrench, turn tube retainer counterclockwise to remove (Figure 3-22).
- (4) Gently lift out the light pipe.

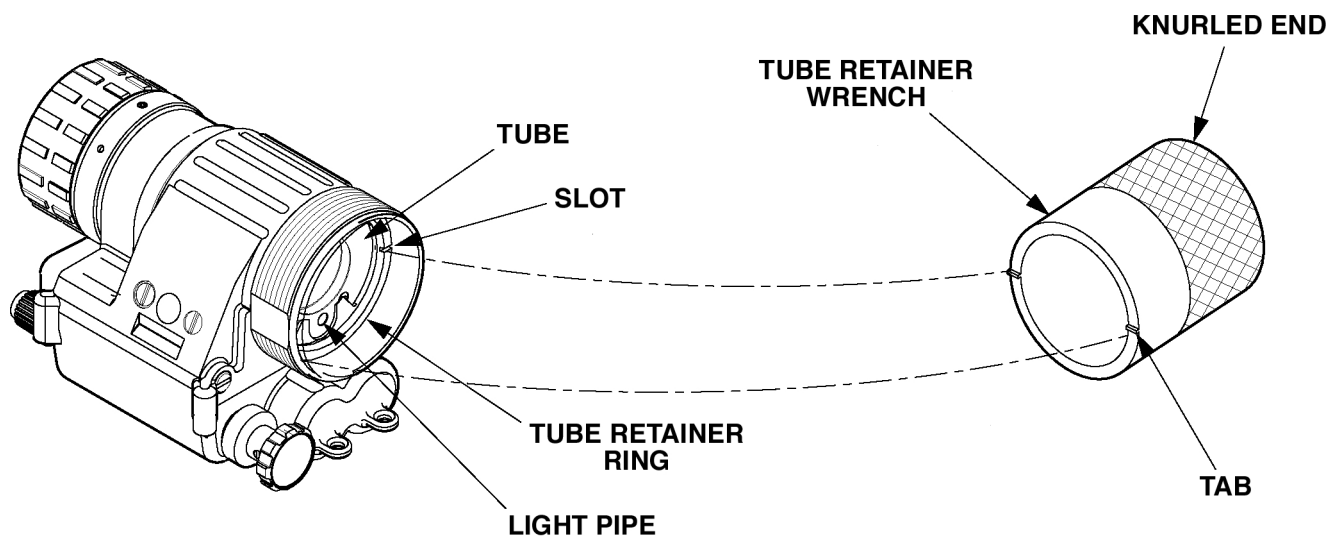

**Figure 3-22. Removal of Tube Retainer.**

**NOTE**

Take care not to damage the flex circuit or tube connector.

- (5) Slide the image intensifier straight out of monocular housing. Flex circuit must be carefully fed through side of housing.
- (6) Place on lens paper and set aside.

**INSTALLATION**

- (1) Examine the objective lens glass surface inside the monocular housing for cleanliness. Using a cotton-tipped applicator and isopropyl alcohol, clean the inside glass lens surface.

**3-15 REMOVAL AND INSTALLATION OF IMAGE INTENSIFIER – Continued**

- (2) Use canned air or nitrogen to blow any dust or debris from the lens surface.
- (3) Position tube connector and flex circuit as shown in Figure 3-23. Be sure that the flex circuit lays flat along the tube and is not twisted.

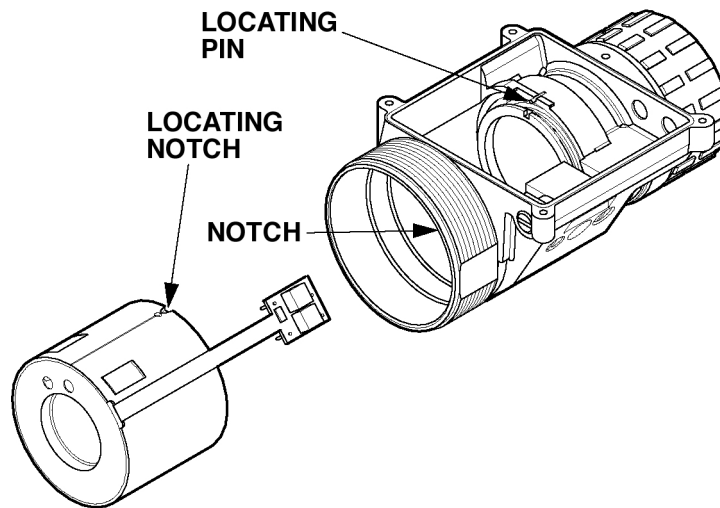

**Figure 3-23. Inserting Tube into Monocular Housing.**

- (4) Gently slide the tube into monocular housing being careful not to allow the flex circuit to become pinched and guide the four-pinned connector out of the tube's path. Orient the tube so that the notch on the tube aligns with the locating pin on the monocular housing.
- (5) Hold the light pipe so that the word "UP" is facing out (Figure 3-24).

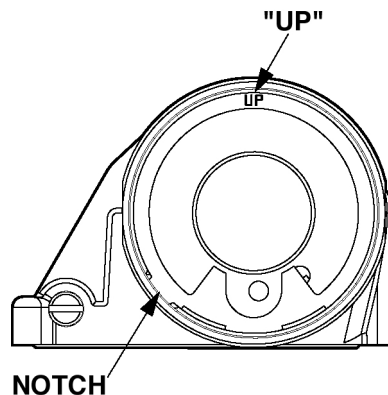

**Figure 3-24. Light Pipe.**



**3-15 REMOVAL AND INSTALLATION OF IMAGE INTENSIFIER – Continued**

**NOTE**

Correct orientation of the light pipe is critical to ensure proper light transmission from the LEDs that serve as IR source and low-battery indicators to the field-of-view.

(6) Orient the light pipe into monocular housing by inserting the outer tab into the opening inside the monocular housing (Figure 3-24).

**NOTE**

- While starting the retainer in the threads of the monocular housing and screwing it in, be sensitive to detect if there is too much resistance indicating that the pieces are cross threading. If you think this is occurring, remove the retainer and inspect it. If there are any doubts about damaged threads on the retainer, obtain a new one and install it. If the threads inside the monocular housing are damaged and will not thread properly, the monocular housing will have to be replaced. To replace monocular housing, (para 3-18).
- To avoid cross threading the tube retainer, use tube retainer wrench to turn the tube retainer counterclockwise until it clicks, then turn clockwise to tighten.

(7) Next, carefully examine the tube retainer. Note that there are notches on both sides of retainer but the notches are deeper on one side (Figure 3-25). On some retainers, one side is beveled, this is the side with the shallower notches. The deeper notches are used to engage the ridges on the tube retainer wrench and the shallower notches provide an air passage within the housing to equalize pressure while focusing the objective and eyepiece lenses during operation of the system.

(8) With the eyepiece end of the monocular housing facing up, insert the retainer so the chamfered edge faces down towards the image intensifier (Figure 3-25).

(9) Insert the tube retainer wrench into monocular housing and gently turn it counterclockwise until you feel it engages the notches of the retainer.

**CAUTION**

Do not over tighten.

(10) Next turn the tube retainer wrench counterclockwise until you hear it click, then carefully turn the tube retainer wrench clockwise until tube retainer is snug.

**3-15 REMOVAL AND INSTALLATION OF IMAGE INTENSIFIER – Continued**

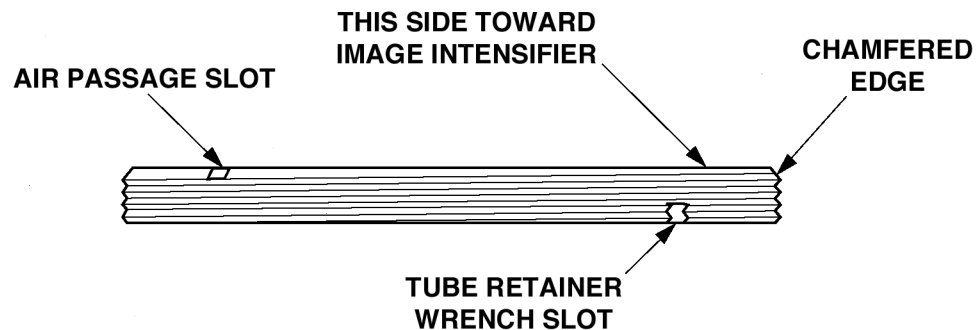

**Figure 3-25. Identifying the Slots for Tube Retainer Wrench.**

- (11) Install battery housing (para 3-14).
- (12) Install eyepiece lens (para 3-12).
- (13) Reset diopter range (para 3-13).
- (14) Reset infinity focus (para 3-17).

**3-16 REMOVAL AND INSTALLATION OF OBJECTIVE LENS**

**INITIAL SETUP**

Test Facility

Clean station in the electronic repair service area

Tools

- Spanner wrench, 1-21/64" (Appendix B, Item 13)
- Alcohol dispenser (Appendix D, Item 5)
- 10X (or greater) eye loop or magnifier (Appendix B, Item 19)

Materials/Parts

- O-ring (Appendix C, Figure C-2, Item 19)
- Compressed air (Appendix D, Item 9)
- Lubricant (Silicone Grease) (Appendix D, Item 2)
- Objective Lens (Appendix C, Figure C-2, Item 18)
- Sealing compound (Appendix D, Item 8)
- Isopropyl alcohol (Appendix D, Item 1)
- Cotton-tipped applicators (Appendix D, Item 10)

**3-16 REMOVAL AND INSTALLATION OF OBJECTIVE LENS – Continued**

**NOTE**

Confirm the monocular is out of warranty period before replacing the objective lens (para 1-7).

**REMOVAL**

- (1) Remove eyepiece lens (para 3-12).
- (2) Remove battery housing (para 3-14).
- (3) Remove image intensifier (para 3-15).
- (4) Using the spanner wrench, access the close focus stop from the eyepiece end and engage the wrench in the slots of the close focus stop (Figure 3-26).

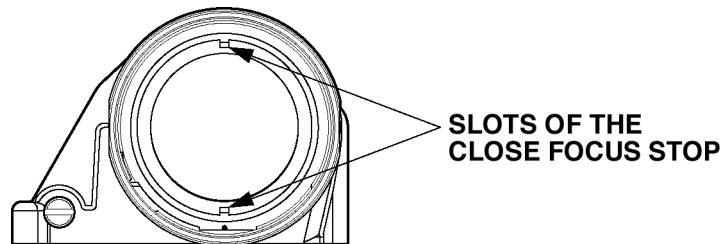

**Figure 3-26. Removing Close Focus Stop Ring.**

- (5) Remove the close focus stop by turning the wrench counterclockwise until all threads are disengaged. Remove close focus stop and set aside (Figure 3-26).

**3-16 REMOVAL AND INSTALLATION OF OBJECTIVE LENS – Continued**

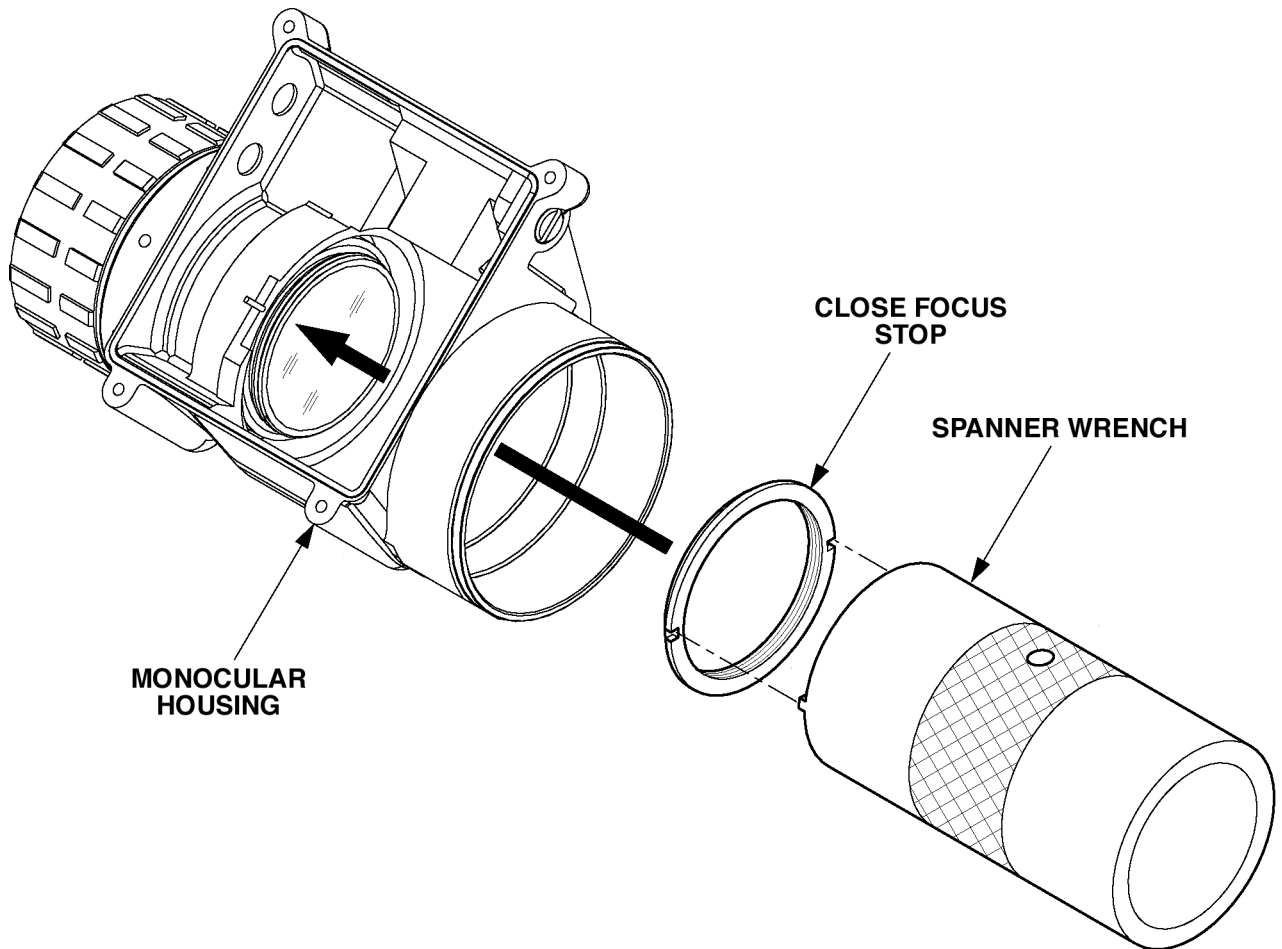

**Figure 3-27. Installation of Close Focus Stop.**

(6) With the objective lens facing you, grasp monocular housing and with the other hand grasp the objective focus ring and rotate counterclockwise until disengaged.

(7) Inspect the O-ring and replace if nicked or cut. If it is defective, replace as described in step 8. If not, proceed to step 9.

**CAUTION**

Do not use a sharp instrument to remove O-ring.

### 3-16 REMOVAL AND INSTALLATION OF OBJECTIVE LENS Continued

(8) To remove O-ring, use your thumb and index finger and squeeze O-ring and at the same time push part of the O-ring out of the groove. Grasp O-ring with the fingers of your other hand and pull it off of the lens cell.

(9) Inspect objective cell and replace if broken, excessively worn, or has damaged parts.

#### CAUTION

Do not get fingerprints or lubricant on the lens surfaces of the cell. Clean the lens immediately with cotton-tipped applicators and either isopropyl alcohol or a non-ammonia spray detergent.

#### **INSTALLATION**

(1) Using a cotton-tipped applicator, apply a light coat of lubricant around the new O-ring and carefully slip it into the groove on the objective cell.

(2) Using a cotton-tipped applicator moistened with isopropyl alcohol, clean excess sealing compound from both close stop focus and objective cell threads as shown in Figure 3-28.

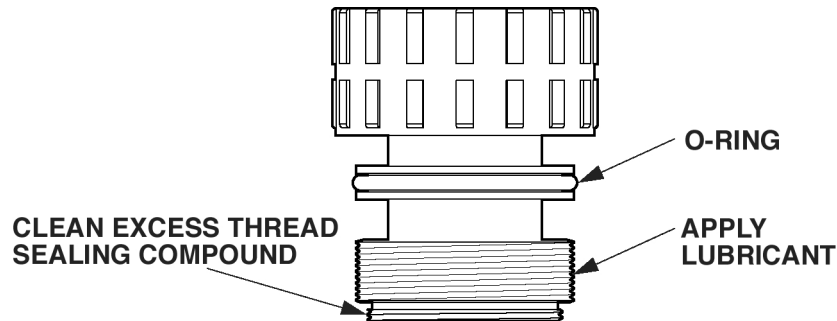

Figure 3-28. Cleaning Excess Sealing Compound.

#### **NOTE**

Take care to avoid getting lubricant on the fine threads where close focus stop will be installed.

### **3-16 REMOVAL AND INSTALLATION OF OBJECTIVE LENS – Continued**

- (3) Apply a coating of lubricant to the threads of the objective cell (Figure 3-28).
- (4) Inspect infinity focus stop and replace if broken, excessively worn, or is damaged. Remove or install (para 3-17).
- (5) Hold monocular housing with the objective end facing you and insert the objective cell. Turn objective cell clockwise until the threads engage and turn clockwise until fully seated.
- (6) Turn monocular housing so that the eyepiece end faces you. Place close focus stop on the wrench and apply two drops of sealing compound to close focus stop.
- (7) With close focus stop still on the wrench, insert close focus stop onto the end of objective cell and by turning the wrench clockwise until close focus stop is threaded on completely. Using a cotton-tipped applicator moistened with isopropyl alcohol, clean away excess sealing compound (Figure 3-28).
- (8) Install image intensifier (para 3-15).
- (9) Install battery housing (para 3-14).
- (10) Install eyepiece lens (para 3-12).
- (11) Reset diopter (para 3-13).
- (12) Reset infinity focus (para 3-17).
- (13) Purge the system.(para 3-19).

### **3-17 OBJECTIVE LENS INFINITY FOCUS SETTING**

#### **INITIAL SETUP**

##### Test Facility

Electronic repair service area. You do not need a dark room to check infinity focus setting; however, it needs to be dim enough to see the targets.

##### Tools

Hex wrench, .050"  
Alcohol dispenser (Appendix D, Item 5)

### 3-17 OBJECTIVE LENS INFINITY FOCUS SETTING – Continued

#### Equipment

Test set, TS-3895A/UV (**Army**) (Appendix B, Item 2)  
Test set, TS-4348/UV (**Marine Corps**) (Appendix B, Item 1)

#### Materials/Parts

Cotton-tipped applicators (Appendix D, Item 10)  
Isopropyl alcohol (Appendix D, Item 1)  
Sealing compound (Appendix D, Item 8)

Use TM 11-5855-264-14, Operator's, Aviation Unit, Direct Support, and General Support Maintenance Manual for TS-3895A/UV test set, to set up the test set and perform self-test.

---

### PROCEDURE

The infinity focus stop may have to be adjusted when a new objective lens or image intensifier is installed on monocular.

- (1) Ensure that objective lens has been installed (para 3-16) and that monocular has been purged (para 3-19).
- (2) Perform the steps of paragraph 3-9 (Initial Setup, Procedure, and Low Light Tube Resolution Test).
- (3) Focus diopter adjustment for best eyepiece focus.
- (4) With objective lens facing away from the operator, rotate objective lens fully clockwise. Using a .050" hex wrench, remove infinity focus setscrew. Turn locking ring counterclockwise.
- (5) Focus objective lens by rotating objective focus ring counterclockwise slightly past best focus (image begins to blur) of the resolution pattern.
- (6) Maintain objective focus setting and use your fingers to rotate infinity focus locking ring clockwise until ring just contacts objective focus knob.

### CAUTION

Applying too much sealing compound, will damage parts.

### 3-17 OBJECTIVE LENS INFINITY FOCUS SETTING - Continued

(7) Apply a small amount of sealing compound on threads of the locking ring setscrew and install in one of the two threaded holes on the infinity focus locking ring. Tighten until fully set. Do not over tighten the setscrew. Over tightening may strip the threads on the infinity focus locking ring. Sealing compound will cure in approximately 10 minutes.

### 3-18 REMOVAL AND INSTALLATION OF MONOCULAR HOUSING

---

#### INITIAL SETUP

##### Test Facility

Clean station in the electronic repair service area

##### Tools

None

##### Equipment

None

##### Materials/Parts

Monocular housing, (Appendix C, Figure C-2, Item 22)

---

#### NOTE

Confirm the monocular is out of warranty period before replacing the battery housing (para 1-7).

#### REMOVAL

- (1) Remove eyepiece lens (para 3-12).
- (2) Remove battery housing (para 3-14).
- (3) Remove image intensifier (para 3-15).
- (4) Remove objective lens (para 3-16).
- (5) Remove purge screw and O-ring.



### **3-18 REMOVAL AND INSTALLATION OF MONOCULAR HOUSING - Continued**

#### **INSTALLATION**

- (1) Replace purge screw and O-ring.
- (2) Replace objective lens (para 3-16).
- (3) Replace image intensifier (para 3-15).
- (4) Replace battery housing (para 3-14).
- (5) Replace eyepiece lens (para 3-12).
- (6) Set zero diopter (para 3-13).
- (7) Set infinity focus (para 3-17).
- (8) Purge the system (para 3-19).

#### **3-19 PURGING**

The housing of monocular (Figure 3-29) is filled with dry nitrogen and sealed to prevent dirt and moisture from degrading the optical performance during use. Perform the following procedure to purge monocular.

**3-19 PURGING - Continued**

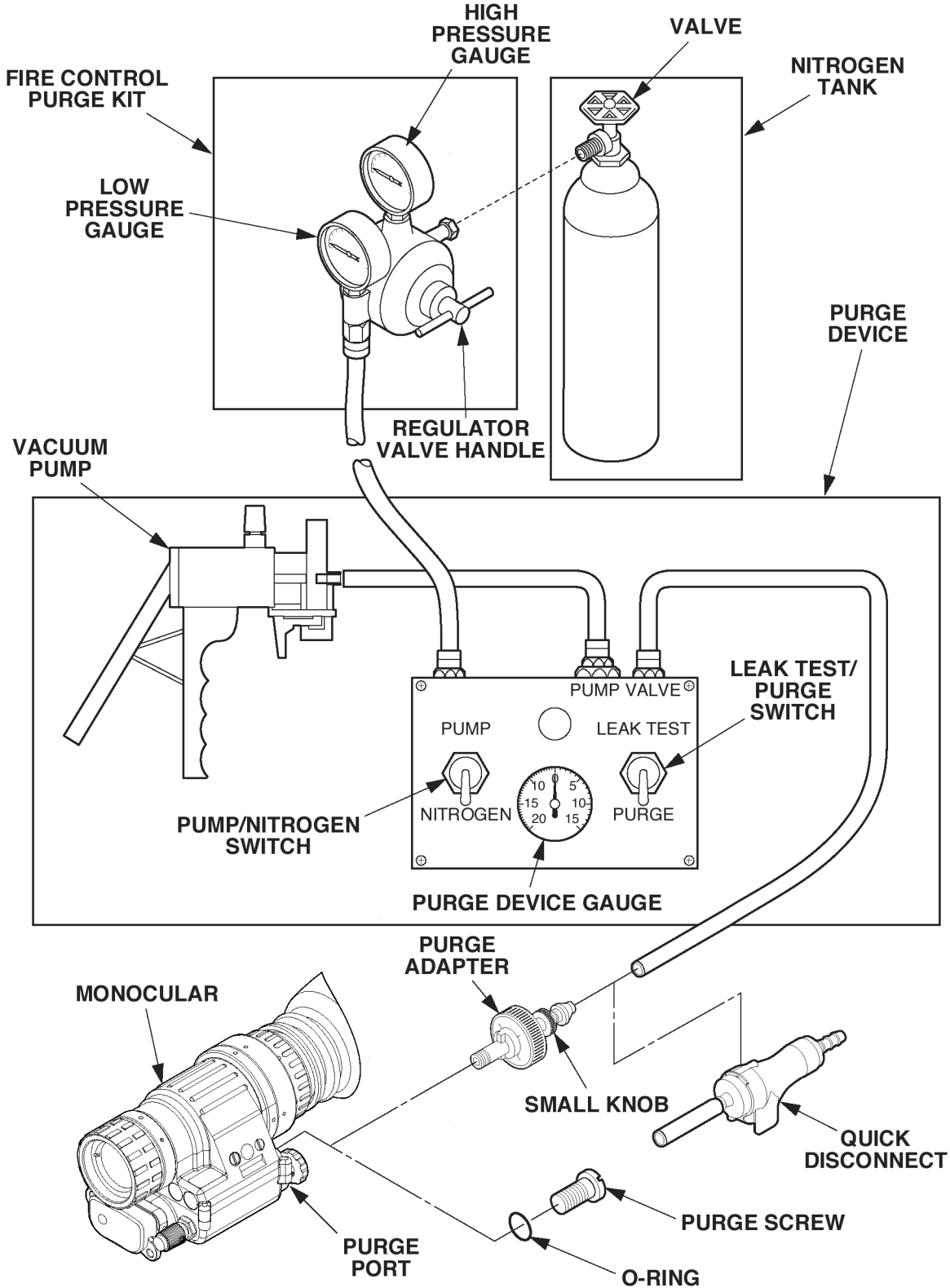

**Figure 3-29. Nitrogen Purging Equipment Setup.**

**3-19 PURGING – Continued**

---

**INITIAL SETUP**

Test Facility

Clean station in the electronic repair service area

Tools

Screwdriver, flat tipped (Appendix B, Item 9)  
Wrench, 1 1/8 inch open end box (Appendix B, Item 15), or equivalent

Equipment

Purge device (Appendix B, Item 5), or commercial equivalent  
Fire Control Purging Kit (Appendix B, Item 8)  
Purge Adapter (Appendix B, Item 7), or commercial equivalent  
Quick Disconnect (optional, commercially available)

Materials/Parts

Nitrogen, Compression type: water pumped  
Composition and percentage: 99.5% nitrogen by volume (Appendix D, Item 4),  
or commercial equivalent  
O-ring (Appendix C, Figure C-2, Item 9)  
Lubricant (Silicone Grease) (Appendix D, Item 2)

References

TM 750-116, General Procedures for Purging and Charging of Fire Control Instruments

---

**WARNING**

**Personnel Injury**

- Serious injury may result if the nitrogen tank valve breaks off due to tank upset. If the tank valve breaks, the tank can be propelled by the escaping gas and strike you or others.
- Always secure the tank to an upright support before removing the tank valve guard and attaching the regulator valve to the tank.

**3-19 PURGING - Continued**

- (1) Connect fire control purging kit using a wrench (Appendix B, Item 15), or equivalent, to nitrogen tank and purge device as shown in Figure 3-29 and in accordance with TM 750-116.
- (2) Ensure that valve is closed on nitrogen tank.
- (3) Set regulator valve handle for zero psi by rotating control until there is no spring pressure on control.
- (4) Remove purge screw and O-ring from purge port of monocular.

**CAUTION**

Do not over tighten purge adapter to prevent damage to O-ring seat.

- (5) Thread purge adapter approximately three turns into the purge port of monocular.
- (6) Attach hose into purge adapter.
- (7) Open nitrogen tank valve. The high pressure gauge will indicate tank pressure. If pressure is below 100 pounds, replace tank.
- (8) Set purge device PUMP/NITROGEN switch to PUMP and the LEAK TEST/PURGE switch to PURGE.
- (9) Slowly adjust regulator valve handle by turning it clockwise until low-pressure gauge indicates 3 to 3.5 psi.
- (10) Pump vacuum handle of purge device until purge device gauge indicates greater than 15 in. Hg (Mercury).
- (11) Purge monocular by positioning purge device PUMP/NITROGEN switch to NITROGEN and observe that purge device gauge indicates 3 to 3.5 psi. If necessary, slowly adjust regulator valve handle until purge device gauge reaches 3 to 3.5 psi.
- (12) Repeat steps 8, 10, and 11 one additional time.
- (13) Turn PUMP/NITROGEN switch to PUMP.
- (14) Set regulator valve handle for zero.
- (15) Turn off nitrogen tank valve.

**NOTE**

Purging monocular is not intended to result in a positive pressure inside monocular. Consequently, it is okay to leave the purge port open briefly after removing purge adapter and purge device hose and before installing O-ring and purge screw.

### **3-19 PURGING - Continued**

(16) Remove hose, then remove purge adapter from the purge port.

(17) Inspect O-ring for signs of damage. Replace, if required. Lubricate O-ring with lubricant and install with the purge screw into the purge port of the monocular and tighten hand tight.

### **3-20 OPERATIONAL CHECKS**

---

#### **WARNING**

Do not use contaminated eyecup or eyeguard. They must be replaced.

Perform the following operational checks after removing and replacing or installing any assemblies of the monocular.

(1) Perform low light and high light tube resolution tests (para 3-9).

(2) Perform operational checks as described in TM 11-5855-306-10, Operator's Manual, Monocular Night Vision Device (MNVD), AN/PVS-14.

### **Section VI. Preparation for Storage and Shipment.**

#### **3-21 PACKING THE MNVD**

Packing procedures for the MNVD are the same as that for unit maintenance. (para 2-23).

#### **3-22 SHIPPING THE IMAGE INTENSIFIER**

If an image intensifier has been replaced and it is still under warranty, refer to paragraph 1-7 for instructions.

Whenever an image intensifier has been replaced, pack the removed image intensifier in the packing and shipping material in which you received the new image intensifier or use equivalent packing material. The original packing and shipping material provides the appropriate protection for the image intensifier.

If the removed image intensifier is out of warranty, turn in the removed image intensifier along with a completed copy of DRMS Form 1930, Hazardous Waste Profile Sheet, into your local Defense Reutilization & Marketing Office (DRMO) for disposal.

## APPENDIX A REFERENCES

---

### A-1 SCOPE

This appendix lists all forms, field manuals, technical manuals, and miscellaneous publications applicable to this manual.

### A-2 FORMS

Inspection and Maintenance Record.....	DA 2404
Hazardous Waste Profile Sheet.....	DRMS 1930
Product Quality Deficiency Report.....	SF 368
Recommended Changes to Equipment Technical Publications.....	DA 2028-2
Recommended Changes to Publications and Blank Forms.....	DA 2028
Recommended Changes to Technical Publications.....	NAVMC 10772
Report of Discrepancy.....	SF 364

### A-3 FIELD MANUALS

First Aid for Soldiers.....	FM 21-11
-----------------------------	----------

### A-4 TECHNICAL MANUALS

Equipment Record Procedures.....	TM 4700-15/1
General Procedures for Purging and Charging of Fire Control Instruments.....	TM 750-116
Operator's and Unit Maintenance Manual (including Repair Parts and Special Tools List) for Test Set, Electronic Systems, TS-4348/UV.....	TM 11-5855-299-12&P
Operator's, Aviation Unit, Direct Support, and General Support Maintenance Manual for TS-3895/UV and TS-3895A/UV Test Set.....	TM 11-5855-264-14
Operator's Manual for Monocular Night Vision Device (MNVD) AN/PVS-14.....	TM 11-5855-306-10
Procedures for Destruction of Electronic Materiel to Prevent Enemy Use (Electronics Command).....	TM 750-244-2

### A-5 MISCELLANEOUS PUBLICATIONS

Army Medical Department Expendable/Durable Items.....	CTA 8-100
Battery Disposition/Disposal Handbook.....	TB 43-0134
Consolidated Index of Army Publications and Blank Forms.....	DA Pam 25-30
Expendable/Durable Items (Except Medical, Class V Repair Parts, and Heraldic Items).....	CTA 50-970
Army Maintenance Management System (TAMMS).....	DA Pam 738-750

**A-6 MARINE CORPS USE**

Equipment Record Procedures.....	TM 4700-15/1
Marine Corps Publication Distribution System .....	MCPDS
Quality Deficiency Report.....	MCO 4855.10
Recommended Changes to Publications/Logistics-Maintenance Data Coding	NAVMC 10772
Tool Kit, Electronic-Optical Repair .....	SL-3-09863A
Transportation and Travel Record of Transportation Discrepancies .....	MCO P4610.19

## APPENDIX B

### MAINTENANCE ALLOCATION CHART (MAC) (ARMY ONLY)

---

#### Section I. Introduction

#### B-1 ARMY MAINTENANCE SYSTEM, MAC

a. This introduction (Section I) provides a general explanation of the maintenance and repair functions authorized at various maintenance levels under the standard Army Maintenance System concept.

b. The MAC in Section II designates overall authority and responsibility for the performance of maintenance functions on the identified end item or component. The application of the maintenance functions to the end item or component will be consistent with the capacities and capabilities of the designated maintenance levels, which are shown on the MAC in column (4) as:

Unit — includes two subcolumn, C (operator/crew) and O (unit) maintenance.

Direct Support — includes an F subcolumn.

General Support — includes an H subcolumn.

Depot — includes a D subcolumn.

c. Section III lists the tools and test equipment (both special tools and common tool sets) required for each maintenance function as referenced from Section II.

d. Section IV contains supplemental instructions and explanatory notes for a particular maintenance function.

#### B-2 MAINTENANCE FUNCTIONS

Maintenance functions will be limited to and defined as follows:

a. Inspect. To determine the serviceability of an item by comparing its physical, mechanical, and/or electrical characteristics with established standards through examination (e.g. by sight, sound, or feel).

b. Test. To verify serviceability by measuring the mechanical, pneumatic, hydraulic, or electrical characteristics of an item and comparing those characteristics with prescribed standard.

c. Service. Operations required periodically to keep an item in proper operating condition; i.e., to clean (includes decontaminate, when required), to preserve, to drain, to paint, or to replenish fuel, lubricants, chemical fluids, or gases.

d. Adjust. To maintain or regulate, within prescribed limits, by bringing into proper position, or by setting the operating characteristics to the specified parameters.

e. Align. To adjust specified variable elements of an item to bring about optimum or desired performance.



f. Calibrate. To determine and cause corrections to be made or to be adjusted on instruments or test, measuring, and diagnostic equipment used in precision measurements. This consists of comparisons of two instruments, one of which is a certified standard of known accuracy, to detect and adjust any discrepancy in the accuracy being compared.

g. Remove/Install. To remove and install the same item when required to perform service or other maintenance functions. Install may be the act of emplacing, seating or fixing into position a spare, repair part, or module (component or assembly) in a manner to allow the proper functioning of the equipment or system.

h. Replace. To remove an unserviceable item and install a serviceable counterpart in its place. "Replace" is authorized by the MAC and assigned maintenance level is shown as the 3d position of the SMR code.

i. Repair. The application of maintenance services<sup>1</sup> including fault location/troubleshooting<sup>2</sup>, removal/installation, and disassembly/assembly<sup>3</sup> procedures, and maintenance actions<sup>4</sup> to identify troubles and restore serviceability to an item by correcting specific damage, fault, malfunction, or failure in a part, subassembly, module (component or assembly), end item, or system.

j. Overhaul. That maintenance effort (service/action) prescribed to restore an item to a completely serviceable/operational condition as required by maintenance standards in appropriate technical publications (i.e. DMWR). Overhaul is normally the highest degree of maintenance performed by the Army. Overhaul does not normally return an item to like new conditions.

k. Rebuild. Consists of those services/actions necessary for the restoration of unserviceable equipment to a like-new condition in accordance with original manufacturing standards. Rebuild is the highest degree of material maintenance applied to Army equipment. The rebuild operation includes the act of returning to zero those age measurements (hours, miles, etc.) considered in classifying Army equipment/components.

### **B-3 EXPLANATION OF COLUMNS IN THE MAC, SECTION II**

a. Column 1, Group Number. Column (1) lists the functional group code numbers, the purpose of which is to identify maintenance-significant components, assemblies, subassemblies, and modules with the next higher assembly.

b. Column 2, Component/Assembly. Column (2) contains the item names of components, assemblies, subassemblies, and modules for which maintenance is authorized.

c. Column 3, Maintenance Function. Column (3) lists the functions to be performed on the item listed in Column 2. (For detailed explanations of these functions, see paragraph B-2).

d. Column 4, Maintenance Level. Column (4) specifies each level of maintenance authorized to

---

<sup>1</sup> Services — Inspect, test, service, adjust, align, calibrate, and/or replace.

<sup>2</sup> Fault locate/troubleshoot — The process of investigating and detecting the cause of equipment malfunctioning; the act of isolating a fault within a system or unit under test.

<sup>3</sup> Disassemble/assemble — Encompasses the step-by-step taking apart (or breakdown) of a spare/functional group coded item to the level of its least component identified as maintenance significant (i.e., assigned an SMR code) for the level of maintenance under consideration.

<sup>4</sup> Actions — Welding, grinding, riveting, straightening, facing, machining, and/or resurfacing.

perform each function listed in column (3), by indicating work time required (expressed as manhours in whole hours or decimals) in the appropriate subcolumn. This work time figure represents the active time required to perform that maintenance function at the indicated level of maintenance. If the number or complexity of the tasks within the listed maintenance function vary at different maintenance levels, appropriate work time figures will be shown for each level. The work time figure represents the average time required to restore an item (assembly, subassembly, component, module, end item, or system) to a serviceable condition under typical field operating conditions. This time includes preparation time (including any necessary disassembly/assembly time), troubleshooting/fault location time, and quality assurance time in addition to the time required to perform the specific tasks identified for the maintenance functions authorized in the MAC. The symbol designations for the various maintenance levels are as follows:

- C — Operator or crew maintenance
- O — Unit maintenance
- F — Direct support maintenance
- L — Specialized Repair Activity (SRA)<sup>5</sup>
- H — General support maintenance
- D — Depot maintenance

e. Column 5, Tools and Equipment Reference Code. Column (5) specifies, by code, those common tool sets (not individual tools), common TMDE, and special tools, special TMDE, and special support equipment required to perform the designated function.

f. Column 6, Remarks Code. When applicable, this column contains a letter code, in alphabetical order, that is keyed to the remarks contained in Section IV.

#### **B-4 EXPLANATION OF COLUMNS IN TOOLS AND TEST EQUIPMENT REQUIREMENTS, SECTION III**

a. Column 1, Tool or Test Equipment Reference Code. The tool or test equipment reference code correlates with a code used in the MAC, Section II, Column (5).

b. Column 2, Maintenance Level. The lowest level of maintenance authorized to use the tool or test equipment.

c. Column 3, Nomenclature. Name or identification of the tool or test equipment.

d. Column 4, National Stock Number. National Stock Number of the tool or test equipment.

e. Column 5, Tool Number. The manufacturer's part number, model number, or type number.

#### **B-5 EXPLANATION OF COLUMNS IN REMARKS, SECTION IV**

a. Column 1, Remarks Code. The code recorded in column 6, Section II.

b. Column 2, Remarks. This column lists information pertinent to the maintenance function being performed as indicated in the MAC, Section II.

---

<sup>5</sup> This maintenance level is not included in Section II, column 4, of the MAC. Functions to this level of maintenance are identified by a work-time figure in the "H" column of Section II, column 4, and an associated reference code is used in the Remarks column (6). This code is keyed to section IV, Remarks, and the SRA complete repair application is explained there.

Section II. Maintenance Allocation Chart for AN/PVS-14.

(1) GROUP NUMBER	(2) COMPONENT/ ASSEMBLY	(3) MAINTENANCE FUNCTION	(4) MAINTENANCE LEVEL					(5) TOOLS AND EQUIP REF CODE	(6) REMARKS CODE
			C	O	F	H	D		
00	AN/PVS-14	INSPECT SERVICE REPAIR		0.1 0.1 0.1					A B
01	MONOCULAR ASSY	INSPECT TEST REPAIR TEST REPAIR		0.1 0.2 0.1		0.3 0.3		1 9 1-3, 13, 4-8, 10-14	C D C C, E, F
0101	EYEPIECE ASSEMBLY	INSPECT REPLACE REPAIR			0.1 0.4 0.3			2,4-8, 10, 15	C, F, G
0102	IMAGE INTENSIFIER NIGHT VISION	INSPECT REPLACE			0.3 0.3			1, 2 3-8, 10-14	C,E, F, H
02	HEADSET ASSEMBLY	INSPECT REPLACE REPAIR	01	0.1 0.1					I

**Section III. Tools and Test Equipment Requirements for AN/PVS-14.**

TOOL OR TEST EQUIPMENT REF CODE	MAINTENANCE LEVEL	NOMENCLATURE	NATIONAL STOCK NUMBER	TOOL NUMBER
1	O, F	Test Set, Electronic System, TS-4348/UV	6625-01-323-9584	80063-A3139775
2	F	Test Set, TS-3895A/UV	6625-01-301-6894	80063-A3134100
3	F	Multimeter	6625-01-139-2512	PSM-45 or equivalent
4	F	Tool Kit, Electronic Equipment, TK-105/G ( <b>Army</b> ) <b>OR</b> Tool Kit, Electronic-Optical Repair TAMCN:E22082E ( <b>Marine Corps</b> )	5180-00-610-8177  5180-01-382-1335	80058-TK105G  TAMCN:E22082E
5	F	Device, Purge	5855-01-246-6815	54490-5007665
6	F	Nitrogen, Technical 336 cubic feet  <b>OR</b> Nitrogen, Technical 81 cubic feet	6830-01-265-4068  6830-00-973-7283	81348- BB-N-411
7	F	Adapter, Goggles, Night Vision	5855-01-151-4211	80063-SM-C-657451
8	F	Purging Kit, Fire Control	4931-00-065-1110	19200-SC4931-95CLJ54
9	O	Tool Kit, Electronic Equipment, TK-101/G ( <b>Army</b> )	5180-00-064-5178	TK101GISSUE6
10	F	Wrench, Spanner	5120-01-175-7134	54490-5007644
11	F	Wrench, Spanner 1-33/64" ( <b>Marine Corps</b> )	5120-00-345-1381	19200-7597632
12	F	Wrench, Retainer, Tube	5120-01-170-5088	54490-5003424
13	F	Wrench, Spanner 1-21/64"	5120-00-345-1406	19200-7597658
14	O, F	Light, IR Transmitter	6240-01-275-8080	80063-A3085081
15	F	Wrench, 1 1/8" Open End Box	5120-01-335-1264	55719-OEX36B
16	F	Pliers, Retaining Ring	5120-00-293-2513	1JH2412PC1H
17	F	Heater, Gun Type, Electric	4940-00-364-2828	750X
18	O, F	Pliers, Needle Nose	5120-00-293-3481	1920
19	F	10X (or greater) eye loop, or magnifier	6650-00-536-5564	7680943

Section IV. Remarks.

REMARKS CODE	REMARKS
A	Service by cleaning the system.
B	Repair by replacing headset assembly, helmet mount, headmount/helmet mount adapter, carrying case, sacrificial window, demist shield, compass assembly, weapon mount, lens covers, eyeguard, eyecup, neck cord or LIF.
C	Dark adaptation takes at least 10 minutes (longer if exposed to bright sunlight) before inspection.
D	Repair by replacing battery cartridge, gain control knob, power switch knob or preformed packing.
E	Repair by replacing image intensifier, monocular housing, battery housing assembly, eyepiece assembly, objective lens assembly, purge screw or preformed packing.
F	Nitrogen purging is required.
G	Repair by replacing locking ring, O-ring, slotted sleeve, focus ring or snap ring.
H	Turn in Image Intensifier to DRMO when out of warranty. Refer to paragraph 1-7, when Image Intensifier is still under warranty.
I	Repair by replacing browpad, chinstrap, neck pad, or strap assemblies.

## APPENDIX C REPAIR PARTS AND SPECIAL TOOLS LIST

---

### Section I. Introduction

#### C-1 SCOPE

This Repair Parts and Special Tools List (RPSTL) authorizes spares and repair parts, special tools, special Test, Measurement, and Diagnostic Equipment (TMDE), and other special support equipment required for performance of direct support maintenance and unit support maintenance of the AN/PVS-14. It authorizes the requisitioning, issue, and disposition of spares, repair parts, and special tools as indicated by the Source, Maintenance, and Recoverability (SMR) codes.

#### C-2 GENERAL

In addition to Section I, Introduction, this Repair Parts and Special Tools List is divided into the following sections:

- a. Section II. Repair Parts List. A list of spares and repair parts authorized by this RPSTL for use in the performance of maintenance. The list also includes parts that must be removed for replacing authorized parts. The parts lists are composed of functional groups in ascending alphanumeric sequence, with the parts in each group listed in ascending figure and item number sequence. Items listed are shown on the associated illustration(s)/figure(s).
- b. Section III. Special Tools List. A list of special tools authorized by this RPSTL (as indicated by Basis of Issue (BOI) information in DESCRIPTION AND USABLE ON CODE column) for the performance of maintenance.
- c. Section IV. National Stock Number and Part Number Index. A list, in National Item Identification Number (NIIN) sequence, of all national stock numbered items appearing in the list, followed by a list in alphanumeric sequence, of all part numbers appearing in the lists. National stock numbers and part numbers are cross-referenced to each illustration figure and item number appearance.

#### C-3 EXPLANATION OF COLUMNS (Sections II and III).

- a. ITEM NO. (Column (1)). Indicates the number used to identify items called out in the illustration.
- b. SMR CODE (Column (2)). The SMR code is a 5-position code containing supply/requisitioning information, maintenance level authorization criteria, and disposition instructions, as explained in Table C-1.

Table C-1. Application of Joint Services SMR Codes.

SOURCE		MAINTENANCE					
		USE		REPAIR			
1 <sup>ST</sup> POSITION		2 <sup>ND</sup> POSITION		3 <sup>RD</sup> POSITION		4 <sup>TH</sup> POSITION	
P	PROCURE	A	REPLENISH	O	REPLACE OR USE AT ORG LEVEL	Z	NO REPAIR (CONSUMABLE)
		B	INSURANCE				
		C	CURE DATED				
		D	INITIAL	F	REPLACE OR USE AT IMA LEVEL	B	RECONDITION BY ADJUSTMENT, CALIBRATION, LUBRICATION, PLATING, ETC.
		E	END ITEM GSE/STOCKED				
		F	GSE/NOT STOCKED				
K	REPAIR KIT COMPONENT	F	ORG/IMA	G	REPLACE OR USE AT SPECIALIZED IMA	O	REPAIR AT ORGANIZATIONAL LEVEL
		D	DEPOT	L			
		B	BOTH KITS				
M A	MANUFACTURE ASSEMBLE	O	ORG	D	REPLACE OR USE AT DEPOT	F	REPAIR AT IMA LEVEL
		F	AFLOAT				
		H	ASHORE				
		G	BOTH				
X	MISC	D	DEPOT	Z	NOT REQUIRED FOR THIS APPLICATION	L	REPAIR AT SPECIALIZED IMA
		A	REQUEST NHA				
		B	OBTAIN FROM SALVAGE OR ONE TIME BUY			D	REPAIR AT DEPOT OR COMMERCIAL
		C	DIAGRAMS, SCHEMATICS, INSTALL DWGS				

RECOVERABILITY		SERVICE OPTION	
5 <sup>TH</sup> POSITION		6 <sup>TH</sup> POSITION	
Z	NONREPAIRABLE CONDEMN AS INDICATED IN POSITION 3	N	CONSUMABLE GAM ITEM NOT CENTRALLY PROCURED OR STOCK NUMBERED
A	SPECIAL HANDLING FOR DISPOSAL	M	FLR ITEM WITH UNIT COST OVER \$5,000. CHANGE 5 <sup>TH</sup> POSITION TO "D"
O	REPAIRABLE ITEM CONDEMN AT ORGANIZATIONAL LEVEL	T	TRAINING DEVICE ITEM SOURCE CODED PD
H F G	REPAIRABLE ITEM CONDEMN AT IMA LEVEL	G	NORMALLY PROCURED COMMERCIAL, BUT ORGANIC CAPABILITY EXISTS FOR EMERGENCY STOP GAP REQUIREMENTS
		1	(APPLY TO ENGINES)
		2	(APPLIES TO 3 <sup>RD</sup> POSITION)
L	REPAIRABLE ITEM CONDEMN AT SPECIALIZED IMA	3	DESIGNATED LOWEST DEGREE OF IMA REPAIR AUTHORITY
		4	(APPLY TO ENGINES)
		5	(APPLIES TO 3 <sup>RD</sup> POSITION)
D	REPAIRABLE AT DEPOT OR COMMERCIAL	6	SAME AS 1-2-3 EXCEPT ITEM IS FLR COSTING MORE THAN \$5,000
		E	END-TO-END TEST BY IMA REQUIRED PRIOR TO BOM
		J	FLR OR CONSUMABLE CHANGE 5 <sup>TH</sup> POSITION TO "D" UNDER PICA/SICA PROGRAM (APPROVAL REQUIRED)

- c. NATIONAL STOCK NUMBER (Column (3)). This column lists the NSN for the associated part number and manufacturer identified in the PART NUMBER and CAGEC columns to the right.
- d. CAGE CODE (Column (4)). The Commercial and Government Entity (CAGE) is a 5-digit numeric code which is used to identify the manufacturer, distributor, or government agency, etc., that supplies the item.
- e. PART NUMBER (Column (5)). Indicates the primary number used by the manufacturer (individual, company, firm, corporation, or government activity), which controls the design and characteristics of the item by means of its engineering drawings, specifications, standards, and inspection requirements to identify an item or range of items.

**NOTE**

When you use an NSN to requisition an item, the item you receive may have a different part number from the part ordered.

- f. DESCRIPTION AND USABLE ON CODE (UOC) (Column (6)). This column includes the following information:
- (1) The Federal item name and, when required, a minimum description to identify the item.
  - (2) The physical security classification of the item is indicated by the appropriate parenthetical entry, e. g., Phy Sec C1 (C) -Confidential, Phy Sec C1 (S) -Secret, Phy Sec C1 (T) - Top Secret).
  - (3) Items that are included in kits and sets are listed below the name of the kit or set.
  - (4) Spare/repair parts that make up an assembled item are listed immediately following the assembled item line entry.
  - (5) Part numbers for bulk materials are referenced in the column in the line entry for the item to be manufactured/fabricated.
  - (6) When the item is not used with all serial numbers of the same model, the effective serial numbers are shown on the last line of the description (before UOC).
  - (7) The UOC, when applicable (paragraph C-5, Special Information).
  - (8) In the Special Tools List Section, the basis of issue (BOI) appears as the last line(s) in the entry for each special tool, special TMDE, and other special support equipment. When density of equipment supported exceeds density spread indicated in the basis of issue, the total authorization is increased proportionately.
  - (9) The statement "END OF FIGURE" appears just below the last item description in Column 5 for a given figure in both Section II and Section III.
- g. QTY (Column (7)). The QTY (quantity per figure column) indicates the quantity of the item used in the breakout shown on the illustration figure, which is prepared for a functional group, sub-functional group, or assembly. A "V" appearing in this column in lieu of a quantity indicates that the specific quantity is variable and the quantity may vary from application to application.



**C-4. EXPLANATION OF COLUMNS (Section IV).**

a. FIGURE NUMBER and NATIONAL ITEM IDENTIFICATION NUMBER (NIIN) INDEXES.

(1) FIG. column. This column lists the number of the figure where the item is identified/located. The figures are in numerical order in Section II and Section III.

(2) ITEM column. The item number identifies the item associated with the figure listed in the adjacent FIG. column. This item is also identified by the NSN listed on the same line.

(3) STOCK NUMBER column. This column lists the NSN by NIIN sequence. The NIIN consists of the last nine digits of the NSN. An example is shown below.

NSN
<hr/>
5855-01-432-0524
NIIN

When using this column to locate an item, ignore the first four digits of the NSN. However, the complete NSN should be used when ordering items by stock number.

(4) CAGEC column. The Commercial and Government Entity (CAGE) code is a 5-digit numeric code used to identify the manufacturer, distributor, or government agency, etc., that supplies the item.

(5) PART NUMBER column. Indicates the primary number used by the manufacturer (individual, firm, corporation, or government activity), which controls the design and characteristics of the item by means of its engineering drawings, specifications, standards, and inspection requirements to identify an item or range of items.

b. PART NUMBER INDEX. Part numbers in this index are listed by part number in ascending alphanumeric sequence. Vertical arrangement of letter and number combination which places the first letter or digit of each group in order A through Z, followed by the numbers 0 through 9 and each following letter or digit in like order.

(1) CAGEC column. The Commercial and Government entity (CAGE) code is a 5-digit numeric code used to identify the manufacturer, distributor, or government agency, etc., that supplies the item.

(2) PART NUMBER column. Indicates the primary number used by the manufacturer (individual, firm, corporation, or government activity), which controls the design and characteristics of the item by means of its engineering drawings, specifications, standards, and inspection requirements to identify an item or range of items.

(3) STOCK NUMBER column. This column lists the NSN for the associated part number and manufacturer identified in the PART NUMBER and CAGEC columns to the left.

(4) FIG. column. This column lists the number of the figure where the item is identified/located in Section II and III.

(5) ITEM column. The item number is that number assigned to the item as it appears in the figure referenced in the adjacent figure number column.

### C-5 SPECIAL INFORMATION.

a. UOC. The UOC, when applicable, appears at the right side of the Description column, next to the corresponding part number. UOC's identify parts that are not used on all models. Uncoded items are applicable to all models. Examples of UOC's (CODE) and their corresponding model numbers (USED ON) are:

CODE	USED ON
	Not Applicable

### C-6. HOW TO LOCATE REPAIR PARTS.

a. When National Stock Number or Part Number is Not Known:

(1) First. Using the table of contents, determine the assembly group or subassembly group to which the item belongs. This is necessary since figures are prepared for assembly groups and subassembly groups, and listings are divided into the same groups.

(2) Second. Find the figure covering the assembly group or subassembly group to which the item belongs.

(3) Third. Identify the item on the figure and note the item number.

(4) Fourth. Refer to the Repair Parts List for the figure to find the part number for the item number noted on the figure.

(5). Fifth. Refer to the Part Number Index to find the NSN, if assigned.

b. When National Stock Number or Part Number is Known:

(1) First. Using the Index of National Stock Numbers and Part Numbers, find the pertinent National Stock Number or Part Number. The NSN index is in National Item Identification Number (NIIN) sequence (4.1(3)). The part numbers in the Part Number index are listed in ascending alphanumeric sequence (4.b). Both indexes cross-reference you to the illustration figure and item number of the item you are looking for.

(2) Second. After finding the figure and item number, verify that the item is the one you're looking for, then locate the item number in the repair parts list for the figure.

### C-7. ABBREVIATIONS.

TBD = To Be Determined

Section II. Repair Parts List

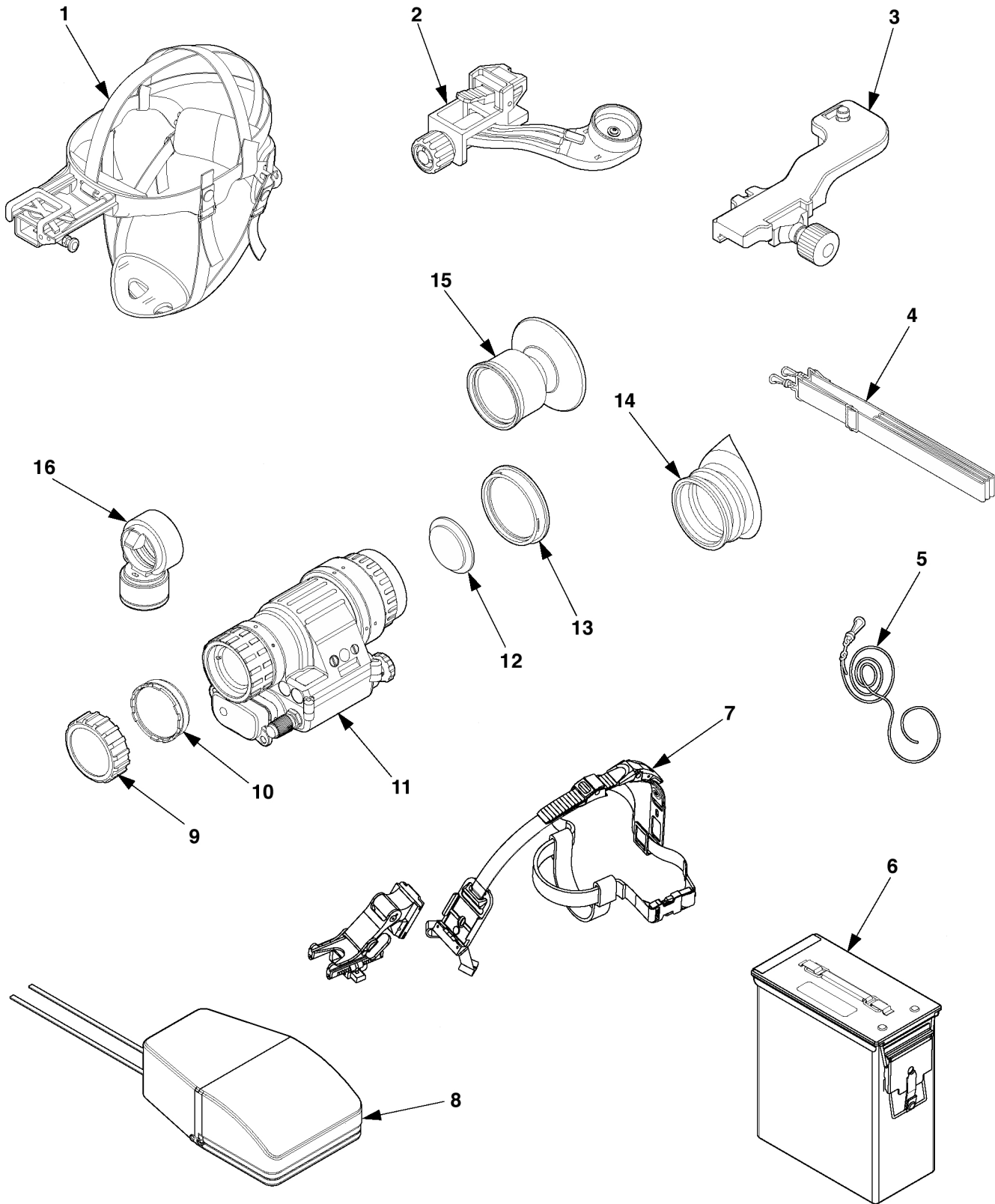

Figure C-1. Monocular Night Vision Device (MNVD), AN/PVS-14 and Accessories.

**Section II. Repair Parts List - Continued**

(1)	(2)	(3)	(4)	(5)	(6)	(7)
ITEM NO.	SMR CODE	NATIONAL STOCK NUMBER	CAGE CODE	PART NUMBER	DESCRIPTION AND USABLE ON CODE (UOC)	QTY
				<b>GROUP 00</b>	<b>AN/PVS-14</b>	
					<b>FIGURE C-1</b>	
1	PAOOO	5855-01-246-8266	80063	A3144268	HEADSET ASSEMBLY (FIGURE C-4 FOR PARTS BREAKDOWN)	1
2	PAOZZ	5965-01-444-1216	80063	A3256347	ADAPTER, HEADSET	1
3	PAOZZ	5340-01-446-8588	80063	A3256348	BRACKET, MOUNTING	1
4	PAOZZ	5855-01-250-2431	80063	A3144267	STRAPPING	1
5	PAOZZ	5340-01-451-7737	80063	A3260933	CLIP, RETAINING	1
6	XBOZZ		80063	A3264350	CASE, SHIPPING AND STORAGE	1
7	PAOZZ	5855-01-457-2953	80063	A3256368	MOUNT, VIEWER	1
8	PAOZZ	5855-01-398-4248	80063	A3187392	CASE, INFRARED EQUIPMENT	1
9	PAOZZ	5855-01-246-8271	80063	A3144264	WINDOW, SACRIFICIAL	1
10	PAOZZ	5855-01-379-1410	54490	5009737	FILTER, INFRARED LIGHT	1
11	XAFFF		80063	A3256340	MONOCULAR ASSY (SEE FIGURE C-2 FOR PARTS BREAKDOWN)	1
12	PAOZZ	5855-01-444-1230	80063	A3256353	LENS, INFRARED RECEIVER	1
13	PAOZZ	5340-01-293-8675	81349	M5501/9-F23	CAP, PROTECTIVE, DUST	1
14	PAOZZ	5855-01-246-8273	80063	A3144422	EYECUP	1
15	PAOZZ	6650-01-444-1229	80063	A3256345	EYEGUARD, OPTICAL INSTRUMENT	1
16	PAOZZ	5855-01-381-6052	80063	A3187430	COMPASS ASSEMBLY	1

END OF FIGURE

Section II. Repair Parts List - Continued

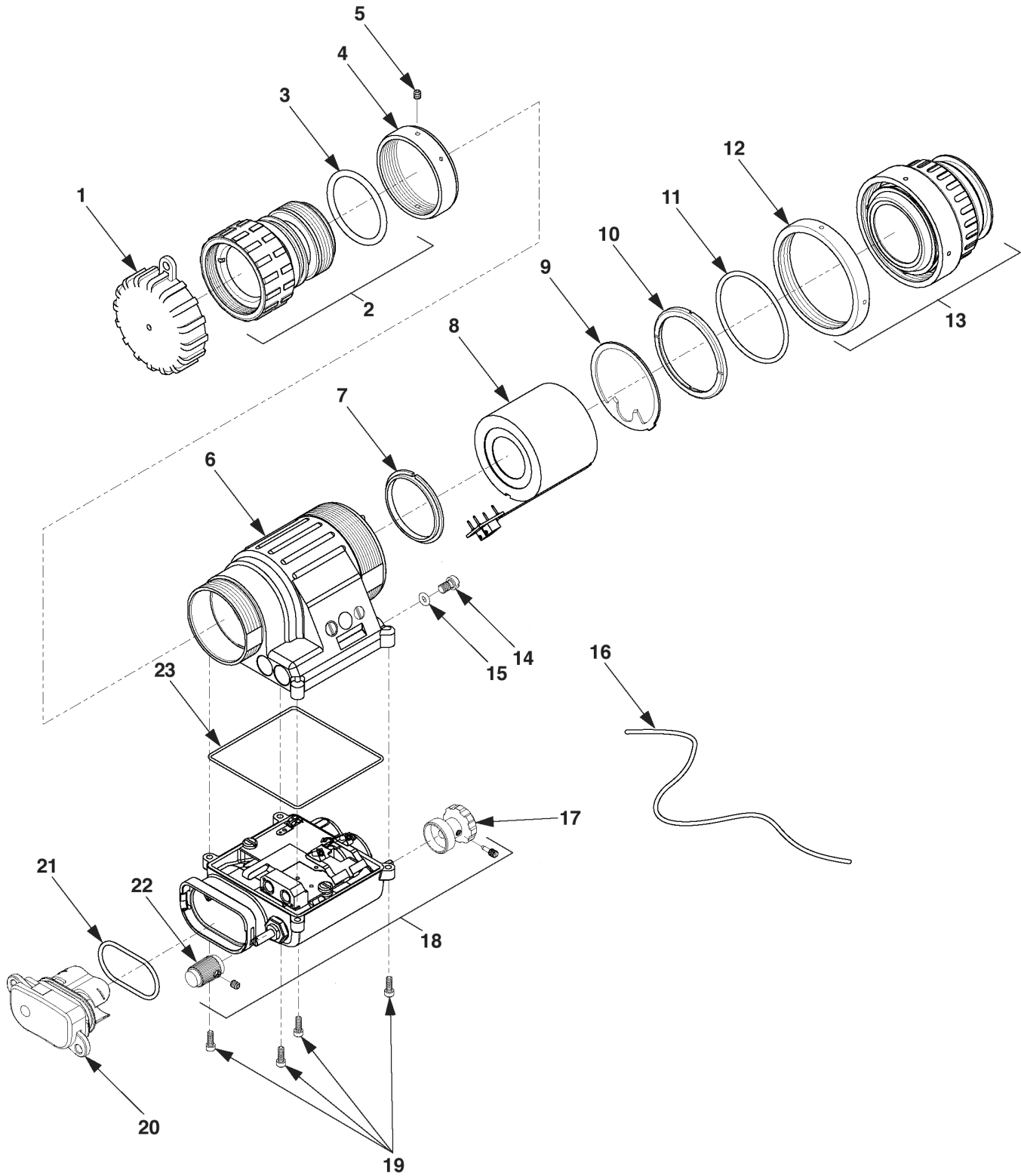

Figure C-2. Monocular Assembly, AN/PVS-14.

**Section II. Repair Parts List - Continued**

(1)	(2)	(3)	(4)	(5)	(6)	(7)
ITEM NO.	SMR CODE	NATIONAL STOCK NUMBER	CAGE CODE	PART NUMBER	DESCRIPTION AND USABLE ON CODE (UOC)	QTY
				<b>GROUP 01</b>	<b>MONOCULAR ASSY</b>	
					<b>FIGURE C-2</b>	
1	PAOZZ	5340-01-397-6608	80063	A3144318	CAP, PROTECTIVE, DUST	1
2	PAFZZ	6650-01-444-1212	80063	A3256342	LENS, OPTICAL INSTRUMENT	1
3	PAFZZ	5330-01-444-1214	80063	A3144323	PACKING, PREFORMED, PART OF ITEM 2	1
4	PAFZZ	5855-01-448-8799	80063	A3256360	RING, RETAINING	1
5	PAFZZ	5305-01-444-1210	80063	A3256357	SETSCREW	1
6	PAFZZ	5855-01-444-1231	80063	A3256341	CELL, OPTICAL ELEMENT	1
7	PAFZZ	5855-01-444-1225	80063	A3144322	RING, RETAINING, OPTICAL	1
8	PAFZA	5855-01-444-3916	80063	A3256350	IMAGE INTENSIFIER, NIGHT	1
9	PAFZZ	6035-01-447-8814	80063	A3256358	LIGHT PIPE	1
10	PAFZZ	5855-01-151-4226	54490	5002569	RETAINER, TUBE	1
11	PAFZZ	5330-00-551-8251	81343	AS3578-028	O-RING	1
12	PAFZZ	5855-01-261-5494	54490	5005838	RING, RETAINING, OPTICAL PART OF ITEM 13	1
13	PAFZZ	5855-01-444-1224	80063	A3256352	EYEPIECE ASSEMBLY (SEE FIGURE C-3 FOR PARTS BREAKDOWN)	1
14	PAFZZ	5305-01-266-9341	80063	A3144315	SCREW, MACHINE	1
15	PAFZZ	5330-01-356-7219	80063	A3144316	PACKING, PREFORMED	1
16	PAOZZ	4020-01-446-8097	80063	A3144306	CORD, FIBROUS	1
17	PAOZZ	5930-01-246-8264	80063	A3144404	SWITCH, KNOB ASSEMBLY	1
18	PAFZZ	5855-01-444-1233	80063	A3256343	BATTERY COMPARTMENT	1
19	PAFZZ	5305-00-409-4438	96906	MS16995-2B	SCREW, CAP, SOCKET, HEX	4
20	PAOZZ	6160-01-444-1208	80063	A3256344	COVER, BATTERY RETAINER	1
21	PAOZZ	5330-00-822-3691	81343	AS3578-021	O-RING, PART OF ITEM 20	1
22	PAOZZ	5355-01-444-1232	80063	A3256351	KNOB, PART OF ITEM 18	1
23	PAFZZ	5330-01-444-1227	80063	A3256356	PACKING, PREFORMED	1

END OF FIGURE

Section II. Repair Parts List - Continued

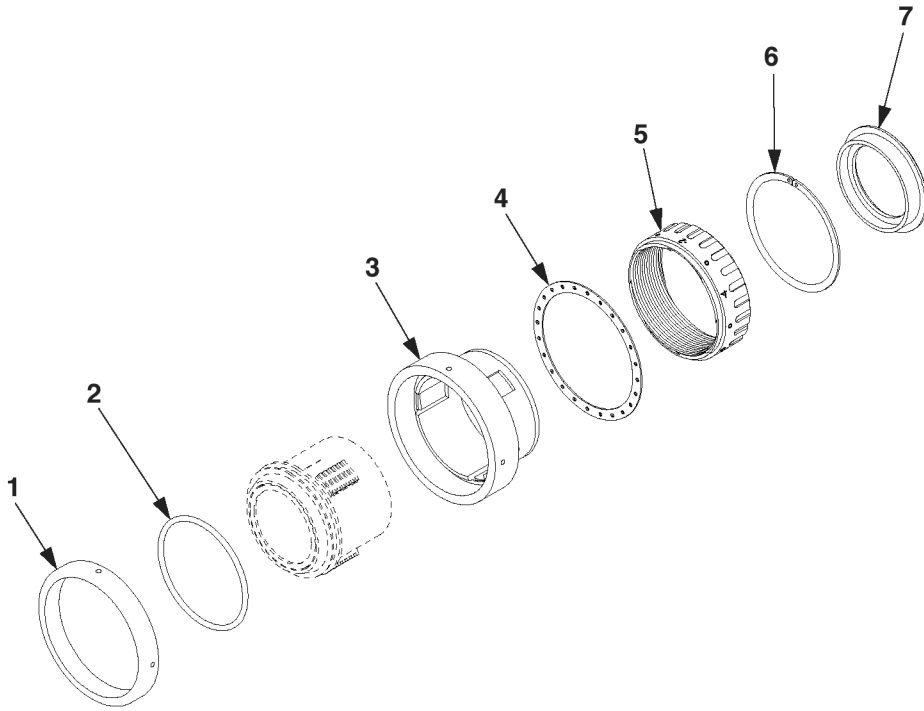

Figure C-3. Eyepiece Assembly.

**Section II. Repair Parts List - Continued**

(1)	(2)	(3)	(4)	(5)	(6)	(7)
ITEM NO.	SMR CODE	NATIONAL STOCK NUMBER	CAGE CODE	PART NUMBER	DESCRIPTION AND USABLE ON CODE (UOC)	QTY
				<b>GROUP 0101</b>	<b>EYEPIECE ASSEMBLY</b>	
					<b>FIGURE C-3</b>	
1	PAFZZ	5855-01-261-5494	54490	5005838	RING, RETAINING, OPTI	1
2	PAFZZ	5330-00-551-8251	96906	AS3578-028	O-RING	1
3	PAFZZ	5855-01-380-9950	54490	5009547	MOUNT VIEWER	1
4	PAFZZ	6650-01-381-2117	54490	5009551	SCALE, DIOPTR	1
5	PAFZZ	5855-01-380-5100	54490	5009549	SNAP, EYEPIECE	1
6	PAFZZ	5855-01-380-5097	54490	5009550	RING, RETAINING	1
7	PAFZZ	4920-01-466-7891	80063	A3256354	RING RETAINING EYEPIECE	1

END OF FIGURE



Section II. Repair Parts List - Continued

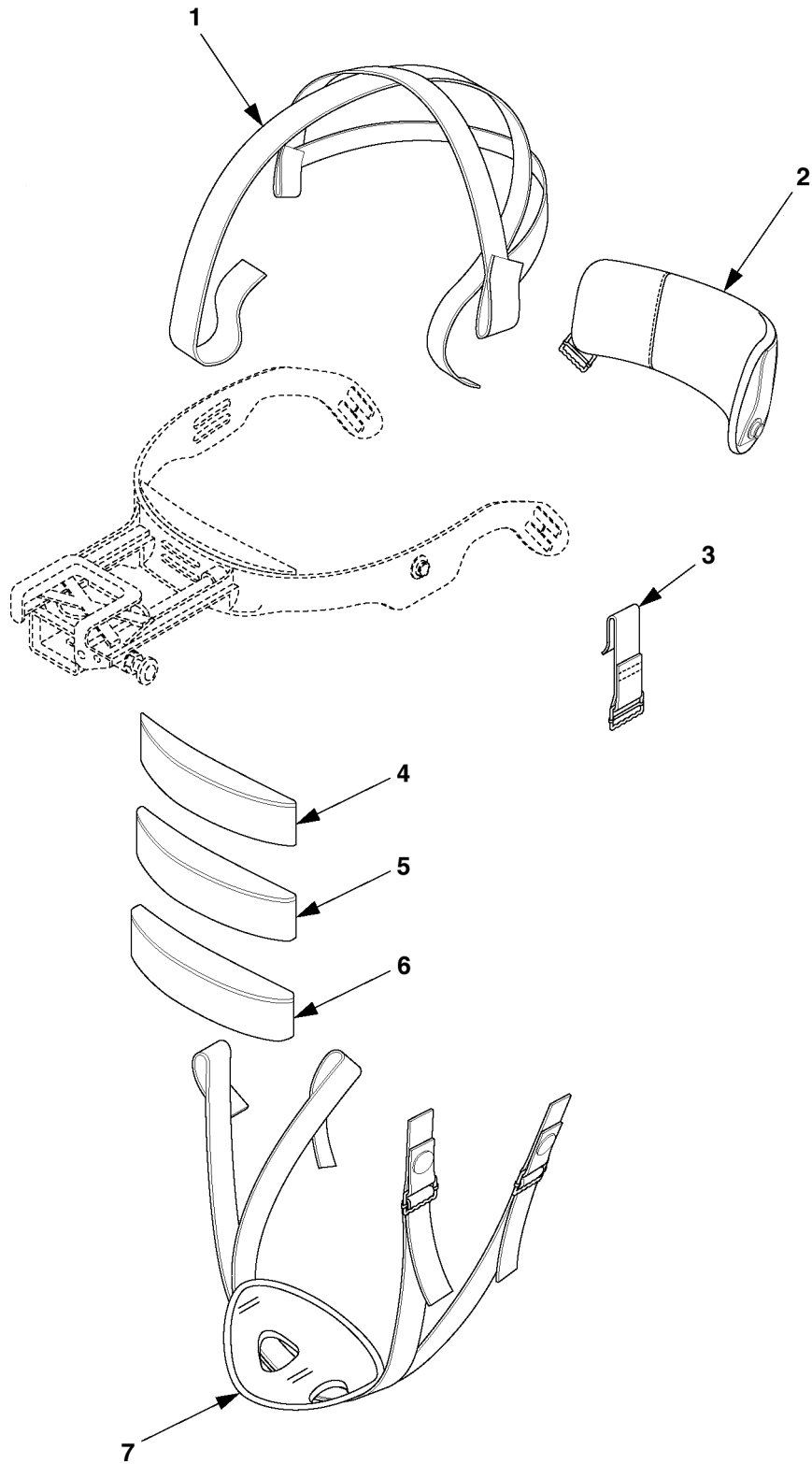

Figure C-4. Headset Assembly.

**SECTION II. Repair Parts List – Continued**

(1)	(2)	(3)	(4)	(5)	(6)	(7)
ITEM NO.	SMR CODE	NATIONAL STOCK NUMBER	CAGE CODE	PART NUMBER	DESCRIPTION AND USABLE ON CODE (UOC)	QTY
				<b>GROUP 02</b>	<b>HEADSET ASSY</b>	
					<b>FIGURE C-4</b>	
1	PAOZZ	5340-01-306-9354	80063	A3144292	STRAPPING	1
2	PAOZZ	5855-01-297-7846	80063	A3144290	NECK PAD ASSEMBLY	1
3	PAOZZ	5340-01-360-1724	80063	A3144293	STRAP, WEBBING	1
4	PAOZZ	5855-01-297-7847	80063	A3144436	BROWPAD, ASSEMBLY, THICK	1
5	PAOZZ	5855-01-355-8600	80063	A3144435	BROWPAD, ASSEMBLY, MEDIUM	1
6	PAOZZ	5855-01-355-8599	80063	A3144280	BROWPAD, ASSEMBLY, THIN	1
7	PAOZZ	5855-01-283-2870	80063	A3144286	STRAP, HELMET	1

END OF FIGURE

Section III. Special Tools List

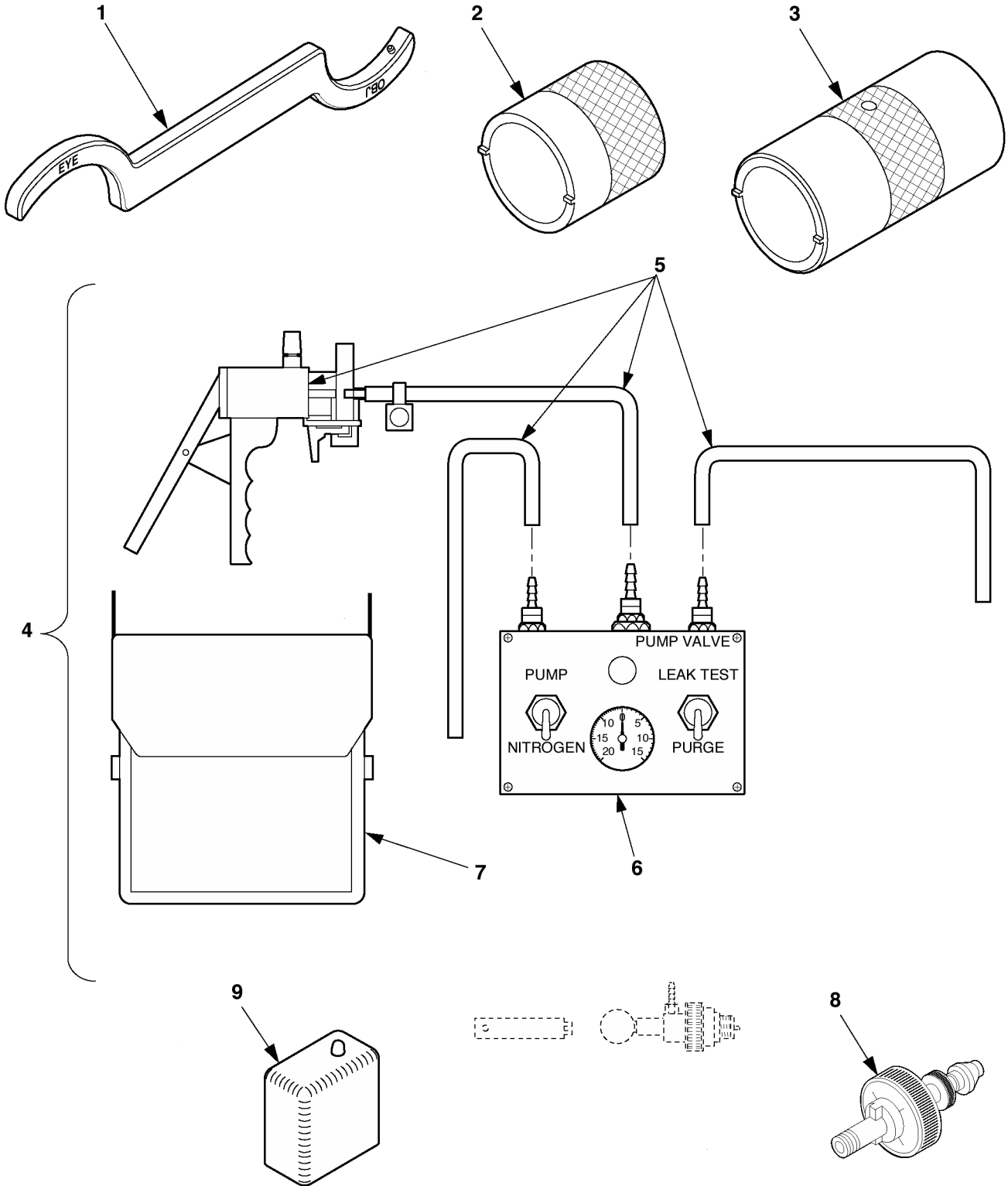

Figure C-5. Special Tools.

**Section III. Special Tools List - Continued**

(1)	(2)	(3)	(4)	(5)	(6)	(7)
ITEM NO.	SMR CODE	NATIONAL STOCK NUMBER	CAGE CODE	PART NUMBER	DESCRIPTION AND USABLE ON CODE (UOC)	QTY
				<b>GROUP 10</b>	<b>SPECIAL TOOLS</b>	
					<b>FIGURE C-5</b>	
1	PAFZZ	5120-01-175-7134	54490	5007644	WRENCH, LOCKING, RING BOI: 1 PER UNIT	1
2	PAFZZ	5120-01-170-5088	54490	5003424	WRENCH, RETAINER, TUB BOI: 1 PER UNIT	1
3	PAFZZ	5120-00-345-1406	19200	7597658	WRENCH, SPANNER BOI: 1 PER UNIT	1
4	PEFFF	5855-01-246-6815	54490	5007665	DEVICE, PURGE	1
5	PAFZZ	5855-01-250-2359	54490	5007678	HOSE SET, VACUUM	1
6	PAFZZ	4820-01-250-2358	54490	5007667	HOUSING, IMAGE INTEN	1
7	PAFZZ	5855-01-250-2361	54490	5007693	CASE, CARRYING	1
8	PAFZZ	5855-01-151-4211	80063	SM-C-657451	PURGE ADAPTER	1
9	PAFZZ	6240-01-275-8080	80063	A3085081	LIGHT, INFRARED TRANSMITTER	1

END OF FIGURE

**Section IV**  
**CROSS-REFERENCE INDEXES**  
**NATIONAL STOCK NUMBER INDEX**

STOCK NUMBER	FIG.	ITEM	CAGEC	PART NUMBER
5120-00-345-1406	C-5	3	19200	7597658
5305-00-409-4438	C-2	19	96906	MS16995-2B
5330-00-551-8251	C-2	11	96906	AS3578-028
5330-00-551-8251	C-3	2	96906	AS3578-028
5330-00-822-3691	C-2	21	96906	AS3578-021
5855-01-151-4211	C-5	8	80063	SM-C-657451
5855-01-151-4226	C-2	10	54490	5002569
5120-01-170-5088	C-5	2	54490	5003424
5120-01-175-7134	C-5	1	54490	5007644
5855-01-246-6815	C-5	4	54490	5007665
5930-01-246-8264	C-2	17	80063	A3144404
5855-01-246-8266	C-1	1	80063	A3144268
5855-01-246-8271	C-1	9	80063	A3144264
5855-01-246-8273	C-1	14	80063	A3144422
5855-01-250-2358	C-5	6	54490	5007679
5855-01-250-2359	C-5	5	54490	5007678
5855-01-250-2361	C-5	7	54490	5007693
5855-01-250-2431	C-1	4	80063	A3144267
5855-01-261-5494	C-2	12	54490	5005838
5855-01-261-5494	C-3	1	54490	5005838
5305-01-266-9341	C-2	14	80063	A3144315
6240-01-275-8080	C-5	9	80063	A3085081
5855-01-283-2870	C-4	7	80063	A3144286
5340-01-293-8675	C-1	13	81349	M5501/9-F23
5855-01-297-7846	C-4	2	80063	A3144290
5855-01-297-7847	C-4	4	80063	A3144436
5340-01-306-9354	C-4	1	80063	A3144292
5855-01-355-8599	C-4	6	80063	A3144280
5855-01-355-8600	C-4	5	80063	A3144435
5330-01-356-7219	C-2	15	80063	A3144316
5340-01-360-1724	C-4	3	80063	A3144293
5855-01-379-1410	C-1	10	54490	5009737
5855-01-380-5097	C-3	6	54490	5009550
5855-01-380-5100	C-3	5	54490	5009549
5855-01-380-9950	C-3	3	54490	5009547
6650-01-381-2117	C-3	4	54490	5009551
5855-01-381-6052	C-1	16	80063	A3187430
5340-01-397-6608	C-2	1	80063	A3144318
5855-01-398-4284	C-1	8	80063	A3187392
6160-01-444-1208	C-2	20	80063	A3256344
5305-01-444-1210	C-2	5	80063	A3256357
6650-01-444-1212	C-2	2	80063	A3256342
5330-01-444-1214	C-2	3	80063	A3144323
5965-01-444-1216	C-1	2	80063	A3256347
4920-01-466-7891	C-3	7	80063	A2356354

**Section IV – Continued**  
**CROSS-REFERENCE INDEXES**  
**NATIONAL STOCK NUMBER INDEX – Continued**

STOCK NUMBER	FIG.	ITEM	CAGEC	PART NUMBER
5855-01-444-1224	C-2	13	80063	A3256352
5855-01-444-1225	C-2	7	80063	A3144322
5330-01-444-1227	C-2	23	80063	A3256356
6650-01-444-1229	C-1	15	80063	A3256345
5855-01-444-1230	C-1	12	80063	A3256353
5855-01-444-1231	C-2	6	80063	A3256341
5355-01-444-1232	C-2	22	80063	A3256351
5855-01-444-1233	C-2	18	80063	A3256343
5855-01-444-3916	C-2	8	80063	A3256350
4020-01-446-8097	C-2	16	80063	A3144306
5340-01-446-8588	C-1	3	80063	A3256348
6035-01-447-8814	C-2	9	80063	A3256358
5855-01-448-8799	C-2	4	80063	A3256360
5340-01-451-7737	C-1	5	80063	A3260933
5855-01-457-2953	C-1	7	80063	A3256368
	C-1	11	80063	A3256340
	C-1	6	80063	A3264350

**Section IV – Continued**  
**CROSS-REFERENCE INDEXES**  
**PART NUMBER INDEX**

CAGEC	PART NUMBER	STOCK NUMBER	FIG.	ITEM
80063	A3085081	6240-01-275-8080	C-5	9
80063	A3144404	5930-01-246-8264	C-2	17
80063	A3144264	5855-01-246-8271	C-1	9
80063	A3144267	5855-01-250-2431	C-1	4
80063	A3144268	5855-01-246-8266	C-1	1
80063	A3144280	5855-01-355-8599	C-4	6
80063	A3144286	5855-01-283-2870	C-4	7
80063	A3144290	5855-01-297-7846	C-4	2
80063	A3144292	5340-01-306-9354	C-4	1
80063	A3144293	5340-01-360-1724	C-4	3
80063	A3144306	4020-01-446-8097	C-2	16
80063	A3144315	5305-01-266-9341	C-2	14
80063	A3144316	5330-01-356-7219	C-2	15
80063	A3144318	5340-01-397-6608	C-2	1
80063	A3144322	5855-01-444-1225	C-2	7
80063	A3144323	5330-01-444-1214	C-2	3
80063	A3144422	5855-01-246-8273	C-1	14
80063	A3144435	5855-01-355-8600	C-4	5
80063	A3144436	5855-01-297-7847	C-4	4
80063	A3187392	5855-01-398-4284	C-1	8
80063	A3187430	5855-01-381-6052	C-1	16
80063	A3256340		C-1	11
80063	A3256341	5855-01-444-1231	C-2	6
80063	A3256342	6650-01-444-1212	C-2	2
80063	A3256343	5855-01-444-1233	C-2	18
80063	A3256344	6160-01-444-1208	C-2	20
80063	A3256345	6650-01-444-1229	C-1	15
80063	A3256347	5965-01-444-1216	C-1	2
80063	A3256348	5340-01-446-8588	C-1	3
80063	A3256350	5855-01-444-3916	C-2	8
80063	A3256351	5355-01-444-1232	C-2	22
80063	A3256352	5855-01-444-1224	C-2	13
80063	A3256353	5855-01-444-1230	C-1	12
80063	A3256354	4920-01-466-7891	C3	7
80063	A3256356	5330-01-444-1227	C-2	23
80063	A3256357	5305-01-444-1210	C-2	5
80063	A3256358	6035-01-447-8814	C-2	9
80063	A3256360	5855-01-448-8799	C-2	4
80063	A3256368	5855-01-457-2953	C-1	7
80063	A3260933	5340-01-451-7737	C-1	5
80063	A3264350		C-1	6
81349	M5501/9-F23	5340-01-293-8675	C-1	13
96906	MS16995-2B	5305-00-409-4438	C-2	19
96906	AS3578-021	5330-00-822-3691	C-2	21
96906	AS3578-028	5330-00-551-8251	C-2	11

**Section IV – Continued**  
**CROSS-REFERENCE INDEXES**  
**PART NUMBER INDEX – Continued**

CAGEC	PART NUMBER	STOCK NUMBER	FIG.	ITEM
96906	AS3578-028	5330-00-551-8251	C-3	2
80063	SM-C-657451	5855-01-151-4211	C-5	8
54490	5002569	5855-01-151-4226	C-2	10
54490	5003424	5120-01-170-5088	C-5	2
54490	5005838	5855-01-261-5494	C-2	12
54490	5005838	5855-01-261-5494	C-3	1
54490	5007665	5855-01-246-6815	C-5	4
54490	5007667	4820-01-250-2358	C-5	6
54490	5007678	5855-01-250-2359	C-5	5
54490	5007693	5855-01-250-2361	C-5	7
54490	5007644	5120-01-175-7134	C-5	1
54490	5009547	5855-01-380-9950	C-3	3
54490	5009549	5855-01-380-5100	C-3	5
54490	5009550	5855-01-380-5097	C-3	6
54490	5009551	6650-01-381-2117	C-3	4
54490	5009737	5855-01-379-1410	C-1	10
19200	7597658	5120-00-345-1406	C-5	3



**Section IV – Continued**  
**CROSS-REFERENCE INDEXES**  
**FIGURE AND ITEM NUMBER INDEX**

FIG.	ITEM	STOCK NUMBER	CAGEC	PART NUMBER
C-1	1	5855-01-246-8266	80063	A3144268
C-1	2	5965-01-444-1216	80063	A3256347
C-1	3	5340-01-446-8588	80063	A3256348
C-1	4	5855-01-250-2431	80063	A3144267
C-1	5	5340-01-451-7737	80063	A3260933
C-1	6		80063	A3264350
C-1	7	5855-01-457-2953	80063	A3256368
C-1	8	5855-01-398-4284	80063	A3187392
C-1	9	5855-01-246-8271	80063	A3144264
C-1	10	5855-01-379-1410	54490	5009737
C-1	11		80063	A3256340
C-1	12	5855-01-444-1230	80063	A3256353
C-1	13	5340-01-293-8675	81349	M5501/9-F23
C-1	14	5855-01-246-8273	80063	A3144422
C-1	15	6650-01-444-1229	80063	A3256345
C-1	16	5855-01-381-6052	80063	A3187430
C-2	1	5340-01-397-6608	80063	A3144318
C-2	2	6650-01-444-1212	80063	A3256342
C-2	3	5330-01-444-1214	80063	A3144323
C-2	4	5855-01-448-8799	80063	A3256360
C-2	5	5305-01-444-1210	80063	A3256357
C-2	6	5855-01-444-1231	80063	A3256341
C-2	7	5855-01-444-1225	80063	A3144322
C-2	8	5855-01-444-3916	80063	A3256350
C-2	9	6035-01-447-8814	80063	A3256358
C-2	10	5855-01-151-4226	54490	5002569
C-2	11	5330-00-551-8251	96906	AS3578-028
C-2	12	5855-01-261-5494	54490	5005838
C-2	13	5855-01-444-1224	80063	A3256352
C-2	14	5305-01-266-9341	80063	A3144315
C-2	15	5330-01-356-7219	80063	A3144316
C-2	16	4020-01-446-8097	80063	A3144306
C-2	17	5930-01-246-8264	80063	A3144404
C-2	18	5855-01-444-1233	80063	A3256343
C-2	19	5305-00-409-4438	96906	MS16995-2B
C-2	20	6160-01-444-1208	80063	A3256344
C-2	21	5330-00-822-3691	96906	AS3578-021
C-2	22	5355-01-444-1232	80063	A3256351
C-2	23	5330-01-444-1227	80063	A3256356
C-3	1	5855-01-261-5494	54490	5005838
C-3	2	5330-00-551-8251	96906	AS3578-028
C-3	3	5855-01-380-9950	54490	5009547
C-3	4	6650-01-381-2117	54490	5009551
C-3	5	5855-01-380-5100	54490	5009549
C-3	6	5855-01-380-5097	54490	5009550
C-3	7	4920-01-466-7891	80063	A3256354
C-4	1	5340-01-306-9354	80063	A3144292

**Section IV – Continued**  
**CROSS-REFERENCE INDEXES**  
**FIGURE AND ITEM NUMBER INDEX – Continued**

FIG.	ITEM	STOCK NUMBER	CAGEC	PART NUMBER
C-4	2	5855-01-297-7846	80063	A3144290
C-4	3	5340-01-360-1724	80063	A3144293
C-4	4	5855-01-297-7847	80063	A3144436
C-4	5	5855-01-355-8600	80063	A3144435
C-4	6	5855-01-355-8599	80063	A3144280
C-4	7	5855-01-283-2870	80063	A3144286
C-5	1	5120-01-175-7134	54990	5007644
C-5	2	5120-01-170-5088	54490	5003424
C-5	3	5120-00-345-1406	19200	7597658
C-5	4	5855-01-246-6815	54490	5007665
C-5	5	5855-01-250-2359	54490	5007678
C-5	6	5855-01-250-2358	54490	5007679
C-5	7	5855-01-250-2361	54490	5007693
C-5	8	5855-01-151-4211	80063	SM-C-657451
C-5	9	6240-01-275-8080	80063	A3085081

## APPENDIX D EXPENDABLE AND DURABLE ITEMS LIST

---

### Section I. Introduction.

#### D-1 SCOPE

This appendix lists expendable and durable items that you will need to operate and maintain the Monocular Night Vision Device (MNVD), AN/PVS-14. This listing is for information only and is not authority to requisition the listed items. These items are authorized to you by CTA 50-970, Expendable/Durable Items (Except Medical, Class V Repair Parts, and Heraldic Items) or CTA 8-100, Army Medical Department Expendable/Durable Items.

#### D-2 EXPLANATION OF COLUMNS

- a. Item Number (Column 1). This number is assigned to the entry in the listing for referencing when required.
- b. Level (Column 2). This column identifies the lowest level of maintenance that requires the item.
  - C — Operator/Crew
  - O — Unit Maintenance
  - F — Direct Support Maintenance
  - H — General Support Maintenance
  - D — Depot
- c. National Stock Number (Column 3). This is the NSN assigned to the item; use it to requisition the item.
- d. Description (Column 4). Indicates the federal item name and, if required a description to identify the item. The last line for each item indicates the Commercial and Government Entity Code (CAGEC) in parenthesis followed by the part number.
- e. Unit of Measure (U/M)/Unit of Issue (U/I) (Column 5). This measure is expressed by a two-character alphabetical abbreviation (e.g., DA, IN, PR). If the unit of measure differs from the unit of issue as shown in the Army Master Data File (AMDF), requisition the lowest unit of issue that will satisfy your requirements.

**TM 11-5855-306-23&P**  
**TM 10271A-23&P/2**

**Section II. Expendable and Durable Items List.**

(1)	(2)	(3)	(4)	(5)
Item Number	Level	National Stock Number	DESCRIPTION, CAGEC AND PART NUMBER	U/M U/I
1	F	6810-00-753-4993	ISOPROPYL ALCOHOL, TECHNICAL (81348) TTI735	OZ
2	O	9150-01-132-8871	LUBRICANT (SILICONE GREASE)	
3	O	7930-00-926-5280	DETERGENT, GENERAL PURPOSE, SPRAY NON-AMMONIA (81348) P-D-1747	BX
4	F	6830-01-265-4068	NITROGEN, TECHNICAL (81348) BB-N-411	CF
5	F	3439-00-552-9309	DISPENSER, ALCOHOL	EA
6	O	7920-00-823-9773	TOWEL, SHOP (81348) UU-T-595	MX
7	O	6640-01-459-4239	PAPER, LENS (81348) A-A50177 TYPE 1, CLASS 5	PG
8	F	8030-01-390-7555	COMPOUND, SEALING (05972) 42540	BT
9	F	6830-00-602-2357	COMPRESSED AIR, TECHNICAL (81348) BB-F-1421	CN
10	F	6515-00-303-8250	APPLICATOR, DISPOSABLE, WOOD, COTTON-TIPPED END, STERILE (81348) GG-A-616	PG
11	O	6230-01-259-4495	1 INCH AA FLASHLIGHT (56654) 71011	EA
12	F	8040-01-334-8284	EPOXY, ADHESIVE (04963) DP-190	KT

## APPENDIX E ILLUSTRATED LIST OF MANUFACTURED ITEMS

### Section I. Introduction.

- a. This appendix includes complete instructions for making items authorized to be manufactured or fabricated at the unit or direct support (DS) maintenance level. The black spot test stand is authorized for Unit/DS.
- b. A part number index in alphanumeric order is provided for cross-referencing the part number of the item to be manufactured to the figure that covers fabrication criteria.
- c. All bulk materials needed for manufacture of an item are listed by part number or specification number in a tabular list on the illustration.

### Section II. Manufactured Items Part Number Index.

Fig. No.	Illus. No.	NSN	Description (Part Number, If Applicable)	U/M	Qty Rqd
E-1	1	5855-01-305-8524	BLACK SPOT TARGET	EA	1
E-1	2	N/A	1/2" PLYWOOD, 22 1/2" X 30 (LOCAL PROCUREMENT)	EA	1
E-1	3	N/A	1/2" PLYWOOD, 22 1/2" X 32" (LOCAL PROCUREMENT)	EA	1
E-1	4	N/A	3/4" PINE BOARD, 2" X 35 3/4" WITH 31° MITER ENDS (LOCAL PROCUREMENT)	EA	2
E-1	5	N/A	3/4" PINE BOARD, 2" X 12 1/4" (LOCAL PROCUREMENT)	EA	2
E-1	6	N/A	3/4" PINE BOARD, 5" X 24" (LOCAL PROCUREMENT)	EA	1
E-1	7	N/A	WOOD SCREWS, 3" (LOCAL PROCUREMENT)	EA	4
E-1	8	N/A	WOOD SCREWS, 1 1/4" (LOCAL PROCUREMENT)	EA	18

Section III. Manufactured Items Illustrations.

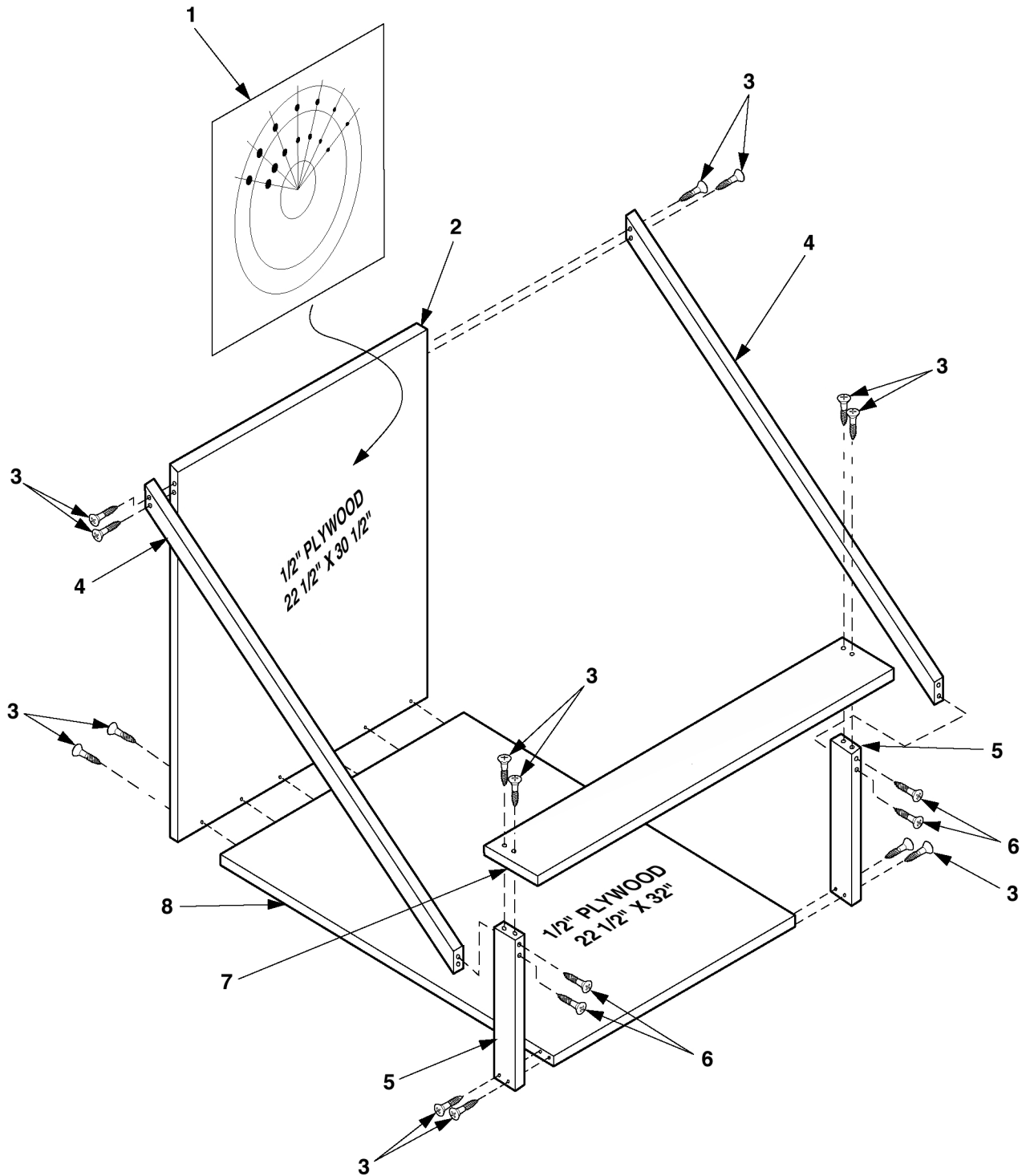

Figure E-1. Black Spot Test Stand.

## GLOSSARY

---

### Section I. Abbreviations.

AMDF	Army Master Data File
BOI	Basis of Issue
CAGEC	Commercial and Government Entity Code
cm	Centimeters
CPC	Corrosion Prevention and Control
CTA	Common Table of Allowances
DA	Department of the Army
DMWR	Depot Modification Work Request
DRMO	Defense Reutilization & Marketing Office
DS	Direct Support
EIC	End Item Code
EIR	Equipment Improvement Recommendation
FM	Field Manual
IR	Infrared
lbs	Pounds
LED	Light-Emitting Diode
LIF	Light Interference Filter
MAC	Maintenance Allocation Chart
MCPDS	Marine Corps Publication Distribution System
mm	Millimeter
MNVD	Monocular Night Vision Device
MTOE	Modified Table of Organization and Equipment
N/A	Not Applicable
NIIN	National Item Identification Number
NSN	National Stock Number
Pam	Pamphlet
PASGT	Personal Armor System Ground Troops
PCB	Printed Circuit Board
PMCS	Preventive Maintenance Checks and Services
POC	Point of Contact
PQDR	Product Quality Deficiency Report
psi	Pounds per Square Inch
Qty	Quantity
RA	Return Authorization
RGA	Return Goods Authorization
RPSTL	Repair Parts and Special Tools List
Rqd	Required
SF	Standard Form
SMR	Source, Maintenance and Recoverability
SRA	Specialized Repair Activity
TAMMS	The Army Maintenance Management System
TBD	To Be Determined
TM	Technical Manual
TMDE	Test, Measurement, and Diagnostic Equipment
U/I	Unit of Issue
U/M	Unit of Measure
UOC	Usable on Code
Vdc	Volts, direct current

## **Section II. Definitions of Unusual Terms.**

**BLACK SPOTS.** These are cosmetic blemishes in the image intensifier of the monocular dirt or debris between the lenses. No action is required if this condition is present unless the spots interfere with the operator's ability to view the outside scene or the ability to perform the mission.

**BRIGHT SPOTS.** These defects can appear in the image area of the MNVD. This condition is caused by a flaw in the film on the microchannel plate. A bright spot is a small, nonuniform, bright area that may flicker or appear constant. Bright spots usually go away when the light is blocked out and are cosmetic blemishes that are signal induced. Not all bright spots make an image intensifier rejectable. Remove the binocular from TS-3895A/UV test set ports (keeping the goggle connector attached) and cup your hand over the lens to block out all light. If the bright spot remains, it is an emission point. If the spot disappears, place the goggles back onto the test set and turn selector knob to HIGH LIGHT for 15 seconds and note the spot's location. Turn selector knob to LOW LIGHT and wait another 15 seconds. If the spot disappears or is faintly visible, it is acceptable.

**BROWPADS.** Three hook-and-pile browpads are provided to adjust the headmount to fit different head sizes. The thin browpad (large head) comes attached to the headmount and the thick (small head) or medium browpads are stored in the carrying case.

**CAUTION.** Condition, practices, or procedures that must be observed to avoid damage to equipment, destruction of equipment, or a long-term health hazard.

**CHICKEN WIRE.** An irregular pattern of dark thin lines in the field-of-view either throughout the image area or in parts of the image area. Under worst case conditions, these lines will form hexagonal or square-wave shaped lines.

**DARK (OR DARK AREA).** A place in which there is very little light. It does not mean total darkness. Generally, this means conditions similar to a quarter-moon or starlit night.

**DARK-ADAPTED.** Having ones eye adjusted to the monocular's output under low light conditions. This takes at least 10 minutes. However, if you have just been exposed to bright sunlight, dark adaptation will take longer.

**DIOPTER.** A unit of measure used to define eye correction. Adjustments to the diopter adjustment will provide a clearer image in each eye.

**EDGE GLOW.** This is a defect in the image area of the MNVD. Edge glow is a bright area (sometimes sparkling) in the outer portion of the viewing area.

**ELEMENT.** A collection of three vertical and three horizontal lines wherein the height and width of each line and the distance between each line is identical. There are six elements in each group of the resolution test pattern.

**EMISSION POINT.** A steady or fluctuating pinpoint of bright light in the image area and does not go away when all light is blocked from the objective lens of the monocular. The position of an emission point within the image area of the monocular does not move. An emission point should not be confused with a point light source in the distance.

**FIXED-PATTERN NOISE.** This is a cosmetic blemish in the image area characterized by a faint hexagonal (honeycomb) pattern throughout the viewing area that most often occurs at high light levels or when viewing very bright lights. Fixed-pattern noise is inherent in the structure of the fiber optics and can be seen in every image intensifier if the light level is high enough.



**FLASHING.** This is a defect in the image area of the MNVD. The image appears to flicker or flash. If there is more than one flicker, check for loose wires, loose cap, or weak batteries.

**FLICKERING.** See “flashing.”

**GAIN.** This is the number of times a night vision device amplifies light input.

**HEADMOUNT.** The adjustable cushioned headmount secures the monocular to the operator's head for night viewing providing freehand support for use with a weapon, protective mask or other purposes.

**IMAGE INTENSIFIER.** An electro-optical device that detects and amplifies ambient light to produce a visual image. It consists of a photocathode, microchannel plate, phosphor screen optic, and integral power supply.

**INFINITY FOCUS.** Adjustment of the objective lens so that a distant object, such as a star or point light on a distant tower, forms the sharpest image.

**INTERMITTENT OPERATION.** This is a defect in the image area of the MNVD. See “flashing”.

**IR SOURCE.** This is an IR Light Emitting Diode (LED). When turned on, the IR source provides additional illumination to enhance existing light conditions used only for performing nearby tasks.

**LIGHT INTERFERENCE FILTER (LIF).** This is a light protection filter for the monocular. Use of this filter will result in a slight reduction in system gain.

**MICROCHANNEL PLATE.** A current-multiplying optical disk that intensifies the electron image produced by the photocathode.

**NOTE.** Essential information of special importance, interest, or aid in job performance.

**OBJECTIVE LENS.** This consists of an objective lens cell and an objective focus ring. It attaches to the front of the monocular and adjusts for variations in distance to the viewed area or object.

**PHOTOCATHODE.** The input optic of an image intensifier that absorbs light energy and in turn releases electrical energy in the form of an electron image.

**SACRIFICIAL WINDOW.** A replaceable sacrificial window is supplied to protect the objective lens during operation in adverse conditions.

**SCINTILLATION.** A faint, random, sparkling effect throughout the image area. Scintillation is a normal characteristic of the image intensifier and should not be confused with emission points. Scintillation is more pronounced under low light conditions. Also called “video noise”.

**SHADING.** The viewed image should be a full circle. If shading is present, you will not see a fully circular image. Shading is indicative of a dying photocathode and is caused by a defective vacuum seal of the image intensifier. Shading is very dark and you cannot see an image through it.

**WARNING.** Conditions, practices, or procedures that must be observed to avoid personal injury or loss of life.

## ALPHABETICAL INDEX

---

<u>Subject</u>	<u>Para</u>
<b>A</b>	
Abbreviations .....	Glossary
Adjustment	
Monocular .....	1-13
Headmount .....	1-13
Ambient light .....	1-1
Ambient temperature limits .....	1-12
Appendices	
A – References .....	A-1
B – Maintenance Allocation Chart (MAC) Army only .....	B-1
C – Repair Parts and Special Tools List .....	C-1
D – Expendable and Durable Items List .....	D-1
E – Illustrated List of Manufactured Items .....	E-1
<b>B</b>	
Battery	
AA size .....	1-12
Alkaline .....	1-12
Installation .....	2-14
Lithium .....	1-12
Low battery Indicator .....	1-15
Removal .....	2-14
Voltage .....	1-15
Battery cartridge	
Installation .....	2-14
Removal .....	2-14
Battery housing	
Installation .....	3-14
Removal .....	3-14
Black spots .....	3-11, Appendix E
Browpads .....	1-10
Installation .....	2-15
Removal .....	2-15

**TM 11-5855-306-23&P**  
**TM 10271A-23&P/2**

Subject

Para

**C**

Capabilities and features .....	1-9
Carrying case .....	1-10, 1-12, 2-11
Characteristics .....	1-9
Chinstrap	
Installation .....	2-17
Removal .....	2-17
Collimator assembly	
Installation .....	3-15
Removal .....	3-15
Common tools and equipment.....	2-1, 3-1
Compass .....	1-10, 2-11
Components	
Installation .....	2-11
Removal .....	2-11
Configuration of image intensifier .....	1-11
Corrosion prevention and control.....	1-8
Cross reference list, nomenclature .....	1-5, Appendix C
Cross-Strap	
Installation .....	2-18
Removal .....	2-18

**D**

Data	
Electrical.....	1-12
Environmental .....	1-12
Equipment .....	1-12
Mechanical .....	1-12, 1-13
Optical .....	1-12
Definition of unusual terms .....	Glossary
Demist shields.....	1-10
Destruction of electronic materiel to prevent enemy use .....	1-3
Diopter .....	1-12, 1-13

Subject

Para

**E**

EIR .....	1-6
Electrical function.....	1-15
Electronic circuit functions .....	1-15
Environmental Data .....	1-12
Equipment	
Characteristics, capabilities and features .....	1-9
Data .....	1-12
Description.....	1-10
Expendable and durable items list .....	Appendix D
Eye relief .....	1-13
Eyecups.....	2-11
Eyepiece lens	
Focus.....	1-12
Function.....	1-14
Installation.....	3-12
Removal.....	3-12
Repair .....	3-12

**F**

Field-of-view .....	1-12
Filter (See LIF)	
Forms	
DA 2404.....	1-7
DA 2407.....	1-7
DA Pam 25-30 .....	1-2, 2-5
DA Pam 738-750 .....	1-2
DD 1149.....	1-7
DRMS 1930 .....	3-21
SF 364 .....	2-5
SF 368 .....	1-6

**G**

Gain control .....	1-10
--------------------	------

**H**

Headmount/Helmet mount adapter .....	1-10, 2-11
Headmount.....	1-10, 2-11
Helmet mount.....	1-10, 2-11
High Light	
Cut-Off .....	1-15
Resolution test .....	2-10, 3-9

**TM 11-5855-306-23&P**  
**TM 10271A-23&P/2**

Subject

Para

**I, J**

Illustrated list of manufactured items .....	Appendix E
Image intensifier	
Inspection criteria for proper image intensifier operation.....	2-8
Installation .....	3-15
Configuration .....	1-11
Removal .....	3-15
Shipping .....	3-22
Infinity focus adjustment.....	3-13
Installation .....	2-6, 2-11
IR illumination.....	1-15
IR Spot/Flood .....	1-10, 2-11

**K**

Knob	
Power switch .....	1-13, 2-12
Installation .....	1-13, 2-12
Removal .....	1-13, 2-12
Gain control.....	1-13, 2-13
Installation .....	1-13, 2-13
Removal .....	1-13, 2-13

**L**

LED .....	1-14
Lens cap .....	1-10, 2-11
LIF.....	1-10, 2-11
Location and description of major components.....	1-10
Low-battery indicator .....	1-15
Low light resolution test.....	2-10, 3-9
Lubrication requirements .....	2-22

Subject

Para

**M**

MTOE .....	3-1
Magnet, Metal Helmet Mount	
Installation.....	2-20
Removal.....	2-20
Maintenance	
Allocation Chart (MAC) .....	2-2, Appendix B
Forms, records, and reports .....	1-2, Appendix A
Major components, location and description .....	1-10
Manufactured items, illustrated list of .....	Appendix E
Mechanical data.....	1-12
Mechanical functions .....	1-13
Monocular.....	1-10
Monocular housing .....	3-18
Installation.....	3-18
Removal.....	3-18

**N**

Neck cord .....	2-11
Neck pad	
Installation.....	2-16
Removal.....	2-16
Nomenclature .....	1-5

**O**

Objective lens	
Focus.....	1-12
Infinity Focus Adjustment .....	3-16
Installation.....	3-16
Operation .....	1-14
Removal.....	3-12
Operating temperature.....	1-12
Operational checks .....	3-20
Operator adjustment limits .....	1-12
Optical	
Check .....	2-10
Data .....	1-12
Optical functions .....	1-14

**TM 11-5855-306-23&P**

**TM 10271A-23&P/2**

Subject

Para

**P, Q**

Packing .....	2-23, 3-21
PMCS table .....	2-7
Power	
Source .....	1-15
Switch .....	1-15
Preparation for storage or shipment .....	1-4
Preparation for using TS-3895A/UV .....	3-8
Purging .....	3-19

**R**

References .....	Appendix A
Refinishing (See Repainting)	
Repainting and refinishing requirements .....	2-21
Repair parts .....	2-3, 3-3
Reporting equipment improvement recommendation .....	1-6
RPSTL .....	Appendix C
Resolution check using TS-4348/UV test set .....	2-10
Resolution testing using TS-3895A/UV test set .....	3-9

**S**

Sacrificial window .....	1-10, 2-11
Scope .....	1-1, 3-6
Service upon receipt of materiel .....	2-5, 3-5
Site and shelter requirements .....	2-4, 3-4
Shipment, preparation for .....	1-4, 2-23, 3-21, 3-22
Shipping and storage case .....	1-10, 1-12
Special tools, TMDE, and support equipment .....	2-2, 3-2, Appendix C
Storage, preparation for .....	2-23, 3-21, 3-22
Storage temperature .....	1-12

**T, U, V**

Temperature limits .....	1-12
Tethering Cord .....	1-10
Test Set	
TS-3895A/UV .....	3-8, 3-9
TS-4348/UV .....	2-10
Tools	
Common .....	Appendix B
Special .....	Appendix C
Troubleshooting	
Direct Support .....	3-7
Electrical .....	3-10
Table .....	3-7
Unit .....	2-9
3X Magnifier .....	1-10

Subject

Para

**W, X, Y, Z**

Warranty information ..... 1-7  
Weight ..... Monocular  
    1-12  
    Shipping and storage case..... 1-12  
Weapon mount ..... 1-10, 2-11  
Zero diopter, setting..... 3-13



**TM 11-5855-306-23&P**  
**TM 10271A-23&P/2**

**(This page intentionally left blank)**

By Order of the Secretary of the Army:

Official:

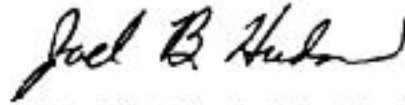

Administrative Assistant to the  
Secretary of the Army  
0017904

ERIC K. SHINSEKI  
*General, United States Army*  
*Chief of Staff*

By Order of the Secretary of the Marine Corps:

RANDALL P. SHOCKEY  
Director, Program Support  
*Marine Corps Systems Command*

DISTRIBUTION:

To be distributed in accordance with the initial distribution number (IDN)  
361522 requirements for TM 11-5855-306-23&P.

RECOMMENDED CHANGES TO EQUIPMENT TECHNICAL PUBLICATIONS



THEN ... JOT DOWN THE DOPE ABOUT IT ON THIS FORM. CAREFULLY TEAR IT OUT. FOLD IT AND DROP IT IN THE MAIL.

**SOMETHING WRONG WITH THIS PUBLICATION**

FROM: (PRINT YOUR UNIT'S COMPLETE ADDRESS)  
 Commander  
 Stateside Army Depot  
 ATTN: AMSTA-US  
 Stateside, N.J. 07703-5007

DATE SENT  
 10 July 1975

PUBLICATION NUMBER TM 11-5840-340-20P	PUBLICATION DATE 23 Jan 74	PUBLICATION TITLE Radar Set AN/PRC-76
--	-------------------------------	--

BE EXACT PIN-POINT WHERE IT IS				IN THIS SPACE TELL WHAT IS WRONG AND WHAT SHOULD BE DONE ABOUT IT:
PAGE NO	PARA-GRAPH	FIGURE NO	TABLE NO	
2-25	2-28			<p>Recommend that the installation antenna alignment procedure be changed throughout to specify a 2<sup>0</sup> IFF antenna lag rather than 1<sup>0</sup>.</p> <p>REASON: Experience has shown that with only a 1<sup>0</sup> lag, the antenna servo system is too sensitive to wind gusting in excess of 25 knots, and has a tendency to rapidly accelerate and decelerate as it hunts, causing strain to the drive train. Hunting is minimized by adjusting the lag to 2<sup>0</sup> without degradation of operation.</p>
3-10	3-3		3-1	<p>Item 5, Function Column. Change "2 dB" to "3 dB".</p> <p>REASON: The adjustment procedure for the TRANS POWER FAULT indicator calls for a 3 dB (500 watts) adjustment to light the TRANS POWER FAULT indicator.</p>
5-6	5-8			<p>add new step f.1 to read, "Replace cover plate removed in step above."</p> <p>REASON: To replace the cover plate.</p>
		FO-3		<p>Line C 3. On J1-2, change "+24 VDC" to "+5 VDC".</p> <p>REASON: This is the output line of the 5 VDC power supply. +24 VDC is the input voltage.</p>

SAMPLE

PRINTED NAME, GRADE OR TITLE AND TELEPHONE NUMBER  
 SSG I. M. DeSpirito 999-1776

SIGN HERE



## SOMETHING WRONG WITH THIS PUBLICATION

FROM: (PRINT YOUR UNIT'S COMPLETE ADDRESS)

DATE SENT

PUBLICATION NUMBER

PUBLICATION DATE

PUBLICATION TITLE

BE EXACT PIN-POINT WHERE IT IS				IN THIS SPACE TELL WHAT IS WRONG AND WHAT SHOULD BE DONE ABOUT IT:
PAGE NO	PARA-GRAPH	FIGURE NO	TABLE NO	

PRINTED NAME, GRADE OR TITLE AND TELEPHONE NUMBER

SIGN HERE

DOTTED LINE

TEAR A

REVERSE OF DA FORM 2028-2

FILL IN YOUR  
UNIT'S ADDRESS

FOLD BACK

DEPARTMENT OF THE ARMY

OFFICIAL BUSINESS

PLEASE  
AFFIX  
STAMP  
POSTAGE  
REQUIRED

Commander  
US Army Communications-Electronics Command  
and Fort Monmouth  
ATTN: AMSEL-LC-LEO-P-MM-T  
Fort Monmouth, New Jersey 07703-5007

TEAR ALONG DOTTED LINE

# THE METRIC SYSTEM AND EQUIVALENTS

## WEIGHT MEASURE

1 Centimeter = 10 Millimeters = 0.01 Meters = 0.3937 Inches  
 1 Meter = 100 Centimeters = 1000 Millimeters = 39.37 Inches  
 1 Kilometer = 1000 Meters = 0.621 Miles

## WEIGHTS

1 Gram = 0.001 Kilograms = 1000 Milligrams = 0.035 Ounces  
 1 Kilogram = 1000 Grams = 2.2 lb.  
 1 Metric Ton = 1000 Kilograms = 1 Megagram = 1.1 Short Tons

## LIQUID MEASURE

1 Milliliter = 0.001 Liters = 0.0338 Fluid Ounces  
 1 Liter = 1000 Milliliters = 33.82 Fluid Ounces

## SQUARE MEASURE

1 Sq. Centimeter = 100 Sq. Millimeters = 0.155 Sq. Inches  
 1 Sq. Meter = 10,000 Sq. Centimeters = 10.76 Sq. Feet  
 1 Sq. Kilometer = 1,000,000 Sq. Meters = 0.386 Sq. Miles

## CUBIC MEASURE

1 Cu. Centimeter = 1000 Cu. Millimeters = 0.06 Cu. Inches  
 1 Cu. Meter = 1,000,000 Cu. Centimeters = 35.31 Cu. Feet

## TEMPERATURE

$5/9(^{\circ}\text{F} - 32) = ^{\circ}\text{C}$   
 212° Fahrenheit is equivalent to 100° Celsius  
 90° Fahrenheit is equivalent to 32.2° Celsius  
 32° Fahrenheit is equivalent to 0° Celsius  
 $9/5^{\circ}\text{C} + 32 = ^{\circ}\text{F}$

## APPROXIMATE CONVERSION FACTORS

TO CHANGE	TO	MULTIPLY BY
Inches	Centimeters	2.540
Feet	Meters	0.305
Yards	Meters	0.914
Miles	Kilometers	1.609
Square Inches	Square Centimeters	6.451
Square Feet	Square Meters	0.093
Square Yards	Square Meters	0.836
Square Miles	Square Kilometers	2.590
Acres	Square Hectometers	0.405
Cubic Feet	Cubic Meters	0.028
Cubic Yards	Cubic Meters	0.765
Fluid Ounces	Milliliters	29.573
its	Liters	0.473
arts	Liters	0.946
allons	Liters	3.785
Ounces	Grams	28.349
Pounds	Kilograms	0.454
Short Tons	Metric Tons	0.907
Pound-Feet	Newton-Meters	1.356
Pounds per Square Inch	Kilopascals	6.895
Miles per Gallon	Kilometers per Liter	0.425
Miles per Hour	Kilometers per Hour	1.609

TO CHANGE	TO	MULTIPLY BY
Centimeters	Inches	0.394
Meters	Feet	3.280
Meters	Yards	1.094
Kilometers	Miles	0.621
Square Centimeters	Square Inches	0.155
Square Meters	Square Feet	10.764
Square Meters	Square Yards	1.196
Square Kilometers	Square Miles	0.386
Square Hectometers	Acres	2.471
Cubic Meters	Cubic Feet	35.315
Cubic Meters	Cubic Yards	1.308
Milliliters	Fluid Ounces	0.034
Liters	Pints	2.113
Liters	Quarts	1.057
ers	Gallons	0.264
ms	Ounces	0.035
ograms	Pounds	2.205
Metric Tons	Short Tons	1.102
Newton-Meters	Pounds-Feet	0.738
Kilopascals	Pounds per Square Inch	0.145
ometers per Liter	Miles per Gallon	2.354
ometers per Hour	Miles per Hour	0.621

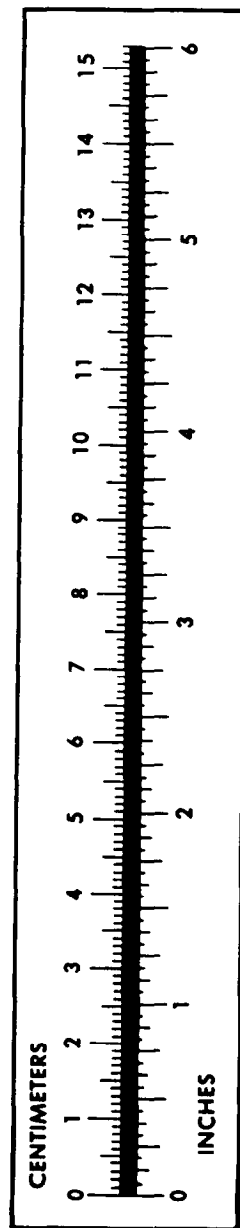

**PIN: 078241-000**